

**SCHAEFER**  
**LEGENDARY STRENGTH**



Dear Friends and Valued Customers,

For over 45 years, Schaefer Marine has stood for strength, quality and innovation. We proudly continue that tradition with our extraordinary product line. From Boom Furlers to Blocks Schaefer works hard to select the right materials with cutting edge designs engineered for the rigors of the challenging Marine environment.

Legendary Strength is just the beginning of the Schaefer story. We've spent years combining technology with unmatched durability to supply you with the reliability you need. Our desire to be the best is more than a cute marketing campaign or a go fast trend; it is a matter of pride and craftsmanship that drives us to succeed. That we are in our 5th decade of manufacturing is a testimony to that fact.

The past few years have seen Schaefer release new products such as our M-Series blocks, Fast Entry Cam Cleats and our new Carbon Fiber Winch Handle. In addition, we've been working on an extraordinary custom articulating mast track for the yacht "Athos" based off of our successful Boom Furling systems. We continue to produce the world's finest Jib Furlers with no compromises in materials to save a bit on production cost. Schaefer simply will only produce what we would install on our own boats.

Recently, we were named the U.S. Distributor for Sea Sure Marine products and Hawk Marine products both based in the U.K. Though different than what we are known for with our extensive manufacturing base, we also have become very adept at getting product into the field in a very effective manner. Take a look at their respective websites for information on their products and let us know if you see something we can have available for you. [www.sea-sure.co.uk](http://www.sea-sure.co.uk) [www.hawkmarineproducts.com](http://www.hawkmarineproducts.com)

As always, we appreciate your continued support. We work hard to gain your trust and your business and always remember that the customer comes first. Look for updates on products and more information online at

[www.schaefermarine.com](http://www.schaefermarine.com) or on Facebook:  
[www.facebook.com/#!/schaefer.marine](https://www.facebook.com/#!/schaefer.marine)

Good Sailing  
Schaefer Marine

## Table of Contents

<b>1. Hardware</b>	<b>4-82</b>
Product Use Chart	1. 4
M-Series Blocks	1. 5-7
Series Blocks	1. 8-23
Wire Blocks / Utility Blocks	1. 24-25
Halyard Control Blocks	1. 26-28
Deck Organizers	1. 29
Cheek Blocks	1. 30
Over the Top Blocks	1. 31
Exit Plates / Blocks	1. 32
Mainsail Accessories	1. 33-35
Travelers	1. 36-43
Snatch Blocks	1. 44
Genoa Blocks	1. 45-51
T-Track / Accessories	1. 52-54
Cleats/Chocks	1. 55-60
Stanchions	1. 61
Cam Cleats	1. 62-63
Eye Straps / Pad Eyes	1. 64-65
Rigging Accessories	1. 66-71
Shackles	1. 72-74
Winch Handles	1. 75
Anchor Hanger	1. 75
Handi-Hangers	1. 75
Rudder Hardware	1. 76
Sheaves	1. 82
<b>2. Jib Furlers</b>	<b>79-91</b>
<b>3. Boom Furlers</b>	<b>92-95</b>
<b>4. TuffLuff</b>	<b>96-97</b>
<b>5. Battslide</b>	<b>98-105</b>
<b>6. Index &amp; Use</b>	<b>106-110</b>

# USAGE CHART

L.O.A. up to 20'. (6m)  
Disp. Up to 2000 lbs. (910kg). Sail Area to 225 sq. ft. (21m<sup>2</sup>)

L.O.A. up to 27'(8m)  
Disp. Up to 5,000 lbs. (2,270kg). Sail Area to 315 sq. ft. (29m<sup>2</sup>)

L.O.A. up to 33'(10m).  
Disp up to 12,000 lbs (5,455kg) Sail Area to 520 sq.ft. (48m<sup>2</sup>)

L.O.A. up to 38' (11.5m) Disp up to 18,000 lbs. (8,182kg). Sail area to 715 sq. ft. (66m<sup>2</sup>)

L.O.A. up to 45' (13.6m) Disp. Up to 30,000 lbs. (13,636kg) Sail area to 900 sq.ft.

<b>CONTROLS MAINSAIL</b>					
End Boom Mainsheet	3 Series	5 Series Blocks	7 Series	8 Series, M66	10 Series, M82
Traveler / End Boom		1 1/8"	1-1/2" System	1-1/2" System	1-1/2" System
Mid-Boom Mainsheet		5 Series Blocks	7/8 Series, M66	8/10 Series, M66	10/12 Series, M82
Traveler / Mid-Boom		1-1/8" System	1-1/2" System	1-1/2" Bridge	1-1/2" Bridge
Boom Vang	3 Series, 35-20	5 Series, 35-04	7 Series, 35-03	7 Series, 35-13	8 Series, M66
Cunningham	2 Series	3 Series	5 Series	5 Series	Consult Schaefer
Full Batten Receptacles	440-10	440-10, 450-10, 1500-10(br)	450-10, 1500-10(br)	1900-10(12, br)	1900-10 (12, br)
<b>GENOA CONTROLS</b>					
Standard Lead Blocks	3 Series	504-82, 505-82	704-92, 705-92	08-92, M66-92	10-92-UC
Twin Sheet Lead Blocks	32-77, 32-88	32-77, 32-88	32-81, 32-97, 32-98	32-81, 32-97, 32-98	32-82, 32-58
Half-Moon Blocks			32-03-UC	32-33-UC	32-33-UC
Foot Blocks		37-15, M66-10	37-15, M66-10	37-45, M82-10	37-53, M82-10
Roller Furler	CF-500	CF-500/ CF-700	1100 / 2100	2100 / 3100	3100
Screacher / Code 0	350	550	650	650	N/A
<b>SPINNAKER CONTROLS</b>					
Spinnaker Halyard	3 Series	5 Series	7 Series	M66, 8 Series	M82, 10 Series
Spinnaker Sheet Leads	3 Series	5 Series	7 Series	M66, 8 Series	M82, 10 Series
Snap Shackles	45-01	45-01	45-05	45-10	45-10
Asymmetrical Tack Line	3 Series	5 Series	5 Series	7 Series, 8 Series	8 Series, M66
Pole Car on mast		73-38	73-38, 73-32	17-87, 73-33	73-33
<b>CONTROL BLOCKS</b>					
Halyard Base	3 Series	5 Series	7 Series	8 Series, M66	10 Series, M82
Over the Top	3 Series	3 Series	5 Series	5 / 7 Series	7 Series

\* These Suggestions are based on common sloop rigs with moderate displacement. If your boat requires a special application, please contact us for advice.



# M Series Blocks - M66

Our M66 range is ideal for use on boats in the 35'- 45' range. Computer machining, Torton™ Rollers, Delrin™ Ball Bearings and Schaefer engineering combine for an incredible strength to weight ratio. Available in eight different configurations for a variety of applications.

**M66-02 Webbing/Lashing Block** \*Does not include Webbing or Lashing  
 L= 3 11/16" (94mm), W= 2 5/8" (66mm), T= 1 1/8" (28mm),  
 Weight = 6oz (170gm)

**M66-05 Single Block**  
 Universal Head design allows free swivel or lock-in. L= 5 13/32" (137mm),  
 W= 2 5/8" (66mm), T= 1 1/8" (28mm), Weight = 9oz (254gm)

**M66-07 Screw In Deck Block**  
 L= 5" (127mm) off of deck, W= 2-5/8" (66mm), T= 1-1/8" (28mm)  
 Weight = 21 ounces (653 gm) Fits 78-77 base on page 58

**M66-10 Foot / Cheek Block**  
 L= 3 11/16" (94mm), W= 2 5/8" (66mm), T= 1 3/32" (27mm),  
 Weight = 7.2oz (204gm)

**M66-20 Low Lead Mast Collar Block**  
 Mounts to 12mm collar post diameter. Clevis pin is 1/4" (6mm) L= 4" (102mm),  
 W= 2 5/8" (66mm), T= 1 1/4" (32mm), Weight = 5.6oz (158gm) SWL=1700 lbs (770kg)

**M66-31 Fixed Lead Block**  
 Aluminum Sheave runs on Nomex™/Teflon™ Bearing and Delrin™ Ball Bearings  
 for high static load strength and low-friction. Requires (3) 1/4" (6mm) FH Fasteners.  
 L= 3 13/16" (96mm), W= 1 1/8" (27mm), H= 3 1/8" (79mm), Weight = 8.5oz (241gm)

**M66-35 Double Block**  
 (Center hub may be used as becket) L= 5-13/32" (137mm) W- 2-5/8" (66mm), T= 1-13/16"  
 (46mm), Weight = 14.5 ounces (451 gm)

**M66-38 Pad Eye Block**  
 Works with Schaefer 78-07, 78-96 and 78-99 Padeyes. L= 4" (102mm), W= 2 5/8"  
 (66mm), T= 1 -1/4" (31mm), Weight = 5.7oz (161gm)

**M66-62 Stand Up Spring Block**  
 Spring allows full 180 degree articulation. Base Dia. 2-3/8" (60mm),  
 Weight 10.4oz (295gm) Requires (4) 1/4" (6mm) FH Fasteners. H= 5" (127mm)

**M66-92 T-Track Genoa Lead**  
 Fits 1 1/4" (32mm) x 3/16" (5mm) T-Track L= 4" (102mm), W= 1 9/16" (39mm),  
 H= 5 1/2" (140mm) Bearing Height = 3" (76mm), Weight = 1lb (454gm)



M66-02



M66-05



M66-07



M66-10



M66-20



M66-31



M66-35



M66-38



M66-62



M66-92

Common Specifications

Cheeks are constructed of machined, hardcoat anodized aluminum. Sheaves are machined aluminum with Torton™ Rollers and Delrin™ ball bearings (except M66-31, utilizing a Nomex™/Teflon Bearing and Delrin™ Ball bearings.)

**Sheave Diameter:** 2-5/8" (66mm)

**Sheave Width:** 1 1/16" (18mm)

**Maximum Line Diameter:** 1/2" (12mm)

**Pin Diameter:** M66-05: 5/16" (8mm) 316 SS

**SWL:** 2800 lbs (1270kg); M66-20 SWL  
 1700 lbs (770kg)

**L** - Length  
**W** - Width  
**T** - Overall Thickness

LEGEND

# M Series Blocks - M82

The M82 is ideal for use on boats in the 45'- 60' range. Continuing the ideas created for our M66 series, the M82 has the same features including computer machining, Torton™ Rollers, Delrin™ Ball Bearings, Hardcoat anodized finish and a smooth, sculpted shape for a light, strong and eye-catching block.

**M82-02 Webbing/Lashing Block** \*Does not include Webbing or Lashing  
 L= 4-1/2" (114mm), W= 3-7/32" (82mm), T= 1 1/8" (28mm),  
 Weight = 9.1oz (258gm)

**M82-05 Single Block**  
 Universal Head design allows free swivel or lock-in. L=5-13/32" (160mm),  
 W= 3-7/32" (82mm), T= 1 1/8" (28mm), Weight = 12.0oz (340gm)

**M82-07 Screw In Deck Block**  
 L = 6-1/4" (159mm) off of deck W = 3-7/32" (82mm), T = 1-1/8" (28mm)  
 Weight = 14.3 ounces (441 gm) Fits 78-77 base on page 58

**M82-10 Foot / Cheek Block**  
 L= 4-1/2" (114mm), W= 3-7/32" (82mm), T= 1 1/8" (28mm),  
 Weight = 12.4oz (352gm). Requires (4) 5/16" (8mm) FH Fasteners.

**M82-20 Low Lead Mast Collar Block** \*\*SWL 3000 lbs  
 Mounts to 14mm collar post diameter. Clevis pin is 5/16" (8mm), L= 4-15/16"  
 (126mm), W= 3-7/32" (82mm), T= 1 1/8" (28mm), Weight = 8.8oz (249gm)

**M82-31 Fixed Lead Block**  
 Aluminum Sheave runs on Nomex™/Teflon™ Bearing and Delrin™ Ball Bearings  
 for high static load strength and low-friction. L= 4-13/16"(122mm), W= 1-7/32"  
 (31mm), H= 3-13/16"(96mm). Requires (4) 5/16" (8mm) FH Fasteners.

**M82-35 Double Block**  
 (center hub may be used as becket) L = 6-13/32" (160mm), W = 3-7/32" (82mm),  
 iT = 2" (51mm), Weight = 21 ounces (653 gm)

**M82-38 Pad Eye Block** \*\*SWL 5000 lbs  
 L= 4-15/16" (126mm), W= 3-7/32" (82mm), T= 1-15/32" (37mm),  
 Weight = 9.1oz (258gm). Works with Schaefer Pad eye 78-17.

**M82-62 Stand Up Spring Block**  
 Spring allows full 180 degree articulation. Base Dia: 2-7/8" (73mm),  
 Weight 40.1oz (1.14kg) Requires (4) 5/16" (8mm) FH Fasteners.  
 H= 6-1/4"(161mm) H2= 3-1/4"(83mm)



M82-02



M82-05



M82-07



M82-10



M82-20



M82-31

## Common Specifications

Cheeks are constructed of machined, hardcoat anodized aluminum. Sheaves are machined aluminum with Torton™ Rollers and Delrin™ ball bearings (except M82-31, utilizing a Nomex™/Teflon Bearing and Delrin™ Ball bearings.)

**Sheave Diameter:** 3-7/32" (82mm)

**Sheave Width:** 3/4" (19mm)

**Maximum Line Diameter:** 5/8" (16mm)

**Pin Diameter:** M82-05: 5/16" (8mm) 17-4 PH

**SWL:** 5000 lbs (2270kg)

\*\*(M82-20 SWL 3000 lbs, 1360kg)

**L** - Length

LEGEND

**W** - Width

**T** - Overall Thickness



M82-35



M82-38



M82-62

# M Series Blocks - M100

Our M100 series is ideal for boats up to 80' (24m). Machined aluminum construction enables a safe working load of up to 7500 lbs. (3410kg). Superior performance is achieved with the use of Torlon™ rollers, Delrin™ ball bearings and Schaefer engineering. M100s are available in 5 configurations to suit your needs.

**M100-02 Webbing/Lashing Block** \*Does not include Webbing or Lashing  
 L=5-1/2" (140mm), W= 3-15/16" (100mm), T= 1 7/16" (36mm),  
 Weight = 20.0oz (567gm)

**M100-05 Single Block**  
 Universal Head design allows free swivel or lock-in. L=7-23/32" (196mm),  
 W= 3-15/16" (100mm), T= 1-7/16" (36mm), Weight = 25.0oz (707gm)

**M100-10 Foot / Cheek Block**  
 L= 5-1/2" (140mm), W= 3-15/16" (100mm), T= 1 7/16" (36mm),  
 Weight = 25.2oz (717gm)

**M100-31 Fixed Lead Block**  
 Aluminum Sheave runs on Nomex™/Teflon™ Bearing and Delrin™ Ball Bearings for high static load strength and low-friction. L= 5-13/16"(147mm), W= 1-7/16"(36mm),  
 H= 4-5/8" (117mm) Requires (4)3/8" (10mm) FH Fasteners.

**M82-62 Stand Up Spring Block**  
 Spring allows full 180 degree articulation. Base Dia. 3-15/16" (100mm),  
 Weight 40.1oz (1.14kg) Requires (4) 3/8" (10mm) FH Fasteners.



M100-02



M100-05



M100-10



M100-31



M100-62

Common Specifications

Cheeks are constructed of machined, hardcoat anodized aluminum. Sheaves are machined aluminum with Torlon™ Rollers and Delrin™ ball bearings (except M100-31, utilizing a Nomex™/Teflon Bearing and Delrin™ Ball bearings.)

**Sheave Diameter:** 3 15/16" (100mm)

**Sheave Width:** 15/16" (23mm)

**Maximum Line Diameter:** 3/4" (19mm)

**Pin Diameter:** M100-05: 3/8" (10MM) 17-4 PH

**SWL:** 7500 Lbs. (3410kg)

**L** - Length

**W** - Width

**T** - Overall Thickness

LEGEND

# 1 Series Blocks

1 Series Blocks, our smallest offerings have introduced many sailors to their first sailing experiences on dinghys, prams and small daysailors around the globe. Offered in a complete range of configurations to meet the needs of todays small boat sailors. 1 Series Blocks are designed and developed with the same care and innovation given to our successful larger blocks.

**01-02 Single Lashing Eye.**

For attachment to line or wire. L=1-13/32" (35mm), W=7/8" (22mm), T=15/32" (12mm), Weight=1oz. (28g)

**01-03 Single Block / Front-Side Shackle.**

Shackle can be attached either direction for a clean lead. L=1-31/32" (50mm), W=7/8" (22mm), T=15/32" (12mm), Weight 1 oz. (28g)

**01-05 Single Block with Swivel Shackle.**

Swivel allows varying line leads. L=2-19/32" (66mm), W=7/8" (22mm), T=15/32" (12mm), Weight=1oz. (28g)

**01-07 Single Block with Swivel Eye.**

7/16" (11mm) inside eye width. L=2-1/32" (52mm), W=7/8" (22mm), T=15/32" (12mm), Weight=1oz. (28g)

**01-12 Single Lashing Eye with Becket.**

Contains stamped stainless becket. L=1-13/16" (46mm), W=7/8" (22mm), T=15/32" (12mm), Weight=1.25 oz. (35g)

**01-13 Single Block / Front-Side Shackle with Becket.**

Becket provides solid dead-end for multi-purchases.

L=2-3/8" (61mm), W=7/8" (22mm), T=15/32" (12mm), Weight 1.25 oz. (35g)



01-02



01-03



01-05



01-07



01-12



01-13

**Common Specifications**

Constructed of tumbled and polished Stainless Steel. High impact Delrin™ sheaves turn on polished, stainless spacers to function with a minimum of friction, even under heavy loading. Head shackles are high quality Stainless Steel with clevis pin and cotter ring attachments.

**Sheave Diameter:** 3/4" (19mm)

**Sheave Width:** 11/32" (9mm)

**Maximum Line Diameter:** 1/4" (6mm)

**Pin Diameter:** 3/16" (5mm)

**SWL:** 750 lbs (340kg)

**L** - Length

**W** - Width

**T** - Overall Thickness

LEGEND

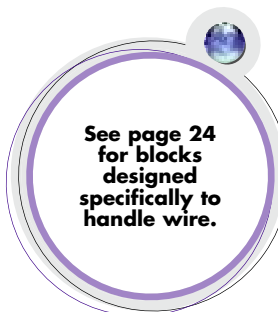

# 2 Series Blocks

2 Series Blocks are perfect for vang, outhauls, backstays, cunninghams and other control blocks on a wide variety of boats.

**02-02 Single Lashing Eye.**

3/8" (9mm) inside eye width. L=2-11/32" (59mm),  
W=1-3/16" (30mm), T=19/32" (15mm), Weight=1.5 oz. (43g)

**02-03 Single Block with Front-Side Shackle.**

L=3-15/32" (88mm), W=1-3/16" (30mm), T=19/32" (15mm), Weight=1.75oz.(50g)

**02-05 Single Block with Swivel Shackle.**

L=3-1/2" (89mm), W=1-3/16" (30mm), T=19/32" (15mm), Weight=2oz.(57g)

**02-07 Single Block with Swivel Eye.**

7/16" (11mm) inside eye width. L=2-3/4" (70mm), W=1-3/16" (30mm),  
T=19/32" (15mm), Weight=1.5 oz. (43g)

**02-13 Single Block with Front-Side Shackle and Becket.**

L=4-5/32" (106mm), W=1-3/16" (30mm), T=1-1/8" (28mm), Weight 3 oz. (85g)

**02-23 Double Block with Front-Side Shackle.**

L=3-15/32" (88mm), W=1-3/16" (30mm), T=1-1/8" (28mm), Weight=3oz. (85g)

**02-24 Double Block with Upset Shackle.**

L=3-9/32" (83mm), W=1-3/16" (30mm), T=1-1/8" (28mm), Weight=3oz.(85g)

**02-33 Double Block with Front-Side Shackle and Becket.**

L=4-5/32" (106mm), W=1-3/16" (30mm), T=1-1/8" (28mm), Weight 3 oz. (85g)

**02-43 Fiddle Block with Side Shackle.**

L=4-7/16" (112mm), W=1-7/8" (48mm), T=15/32" (12mm), Weight=2.5 oz. (71g)

**02-53 Fiddle Block with Side Shackle and Becket.**

L=4-7/8" (124mm), W=1-7/8" (48mm), T=15/32" (12mm), Weight 3.0 oz. (85g)

**25-43 Fiddle Block with V-Jam Cleat.**

L=4-7/16" (112mm), W=2-5/32" (55mm), T=15/32" (12mm), Weight 3 oz. (85g)

**25-53 Fiddle Block with V-Jam Cleat and Becket**

L=4-7/8" (124mm), W=2-5/32" (55mm), T=15/32" (12mm), Weight 3 oz. (85g)

**200-05 Single Block with Ball Bearing Sheave**

L=3-1/2"(89mm), W=1-3/16" (30mm), T=19/32"(15mm), Weight 2oz (57g)

**200-23 Double Block with Ball Bearing Sheaves**

L=3-15/32"(88mm), W=1-3/16"(30mm), T=1-1/8"(28mm), Weight 3oz(85g)

**200-33 Double Block with Becket, Ball Bearing Sheaves**

L=4-5/32"(106mm), W=1-3/16"(30mm), T=1-1/8"(28mm), Weight 3oz(85g)

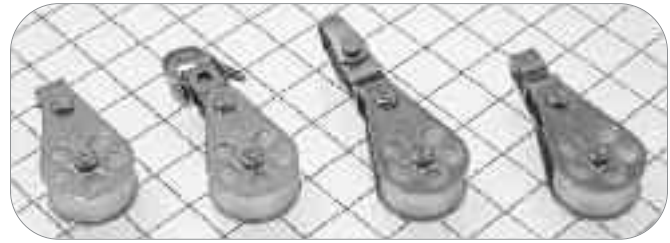

02-02      02-03      02-05      02-07



02-13      02-23      02-24      02-33



02-43      25-43      25-53      02-53



200-05      200-23      200-33

**Common Specifications**

Cheeks are constructed of tumbled and polished stainless steel for maximum resistance to corrosion and cracking common to other plastic designs. Sheaves are made of tough, high impact Delrin™, and turn on polished, stainless steel spacers that prevent the cheeks from binding the sheave even under heavy load.

**Sheave Diameter:** 1-1/16" (27mm)

**Sheave Width:** 3/8" (9mm)

**Maximum Line Diameter:** 5/16" (8mm)

**Pin Diameter:** 3/16" (5mm)

**SWL Stainless:** 900 lbs (410kg)

**SWL Ball Bearing:** 500 lbs (225 kg)

**L** – Length

**W** – Width

**T** – Overall Thickness

LEGEND



# 3 Series Blocks

Schaefer's 3 Series Blocks offer strong, high quality metal construction built to take the punishment associated with running rigging mounted on the deck or spars. Excellent for use on small cruisers, daysailors and high performance racing dinghies.

Mainsheet Systems boats to 25' (7.6m)  
 Halyard Leads boats to 25' (7.6m)  
 Genoa Leads boats to 25' (7.6m)  
 Control Lines boats to 30' (9.1m)



03-02    03-03    03-04    03-05    03-07



300-02    300-05    303-03    303-05



03-15    303-13    303-15

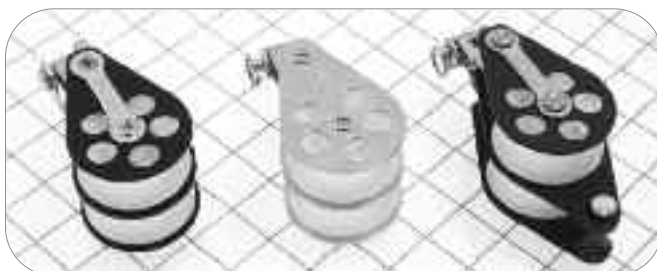

303-23    03-23    303-33

**03-02 Single Stainless Lashing Eye.**

L=2-7/8" (73mm) W=1-9/16" (40mm) T=3/4" (19mm) Weight=2.3oz. (65g)

**03-03 Single Stainless Block with Front-Side Shackle.**

L=3-25/32" (96mm) W=1-9/16" (40mm) T=3/4" (19mm) Weight=2.6oz. (73g)

**03-04 Single Stainless Block with Upset Shackle.**

L=3-23/32" (94mm) W=1-9/16" (40mm) T=3/4" (19mm) Weight=2.7oz. (76g)

**03-05 Single Stainless Block with Swivel Shackle.**

L=3-25/32" (96mm) W=1-9/16" (40mm) T=3/4" (19mm) Weight=2.7oz. (76g)

**03-07 Single Block with Swivel Eye.**

L=3-3/32" (79mm) W=1-9/16" (40mm) T=3/4" (19mm) Weight=2.4oz. (68g)

**300-02 Single Aluminum Ball Bearing Block with Lashing Eye.**

L=2-7/8" (73mm) W=1-9/16" (40mm) T=3/4" (19mm) Weight=1.7oz. (48g)

**300-05 Single Aluminum Ball Bearing Block with Swivel Shackle.**

L=3-25/32" (96mm) W=1-9/16" (40mm) T=3/4" (19mm) Weight=2.4oz. (68g)

**303-03 Single Aluminum Block with Front-Side Shackle.**

L=3-25/32" (96mm) W=1-9/16" (40mm) T=3/4" (19mm) Weight=2.1oz. (59g)

**303-05 Single Aluminum Block with Swivel Shackle.**

L=3-25/32" (96mm) W=1-9/16" (40mm) T=3/4" (19mm) Weight=2.4oz. (68g)

**03-15 Single Stainless Block with Swivel Shackle and Becket.**

L=4-1/2" (114mm) W=1-9/16" (40mm) T=3/4" (19mm) Weight=2.8oz. (79g)

**303-13 Single Aluminum Block with Front-Side Shackle and Becket.**

L=4-1/2" (114mm) W=1-9/16" (40mm) T=3/4" (19mm) Weight=2.7oz. (76g)

**303-15 Single Aluminum Block with Swivel Shackle and Becket.**

L=4-1/2" (114mm) W=1-9/16" (40mm) T=3/4" (19mm) Weight=2.8oz. (79g)

**03-23 Single Stainless Block with Fixed Shackle and Becket.**

L=3-25/32" (96mm) W=1-9/16" (40mm) T=1-7/16" (37mm) Weight=3.3oz. (94g)

**303-23 Single Aluminum Block with Fixed Shackle and Becket.**

L=3-25/32" (96mm) W=1-9/16" (40mm) T=1-7/16" (37mm) Weight=3.3oz. (94g)

**303-33 Single Aluminum Block with Fixed Shackle and Becket.**

L=4-1/2" (114mm) W=1-9/16" (40mm) T=3/4" (19mm) Weight=2.8oz. (79g)

**If you have any questions about your choices, contact Schaefer for assistance.**



# 3 Series Blocks

- 03-45 Stainless Fiddle Block.**  
L=5-3/8" (137mm), W=1-7/8" (48mm), T=3/4" (19mm), Weight 4.40z (125g)
- 303-45 Aluminum Fiddle Block with Swivel Shackle.**  
L=5-3/8" (137mm) W=1-7/8" (48mm) T=3/4" (19mm) Weight=4.4oz. (125g)
- 303-43 Double Aluminum Block with Front-Side Shackle.**  
L=3-25/32" (96mm) W=1-9/16" (40mm) T=1-7/16" (37mm) Weight=4.1oz. (116g)
- 303-53 Aluminum Fiddle Block with Front-Side Shackle and Becket.**  
L=6-7/32" (158mm) W=1-7/8" (48mm) T=3/4" (19mm) Weight=4.7oz. (133g)
- 303-55 Aluminum Fiddle Block with Swivel Shackle and Becket.**  
L=6-7/32" (158mm) W=1-7/8" (48mm) T=3/4" (19mm) Weight=4.8oz. (136g)
- 303-75 Aluminum Fiddle Block with Front Side Shackle and Cam.**  
L=5-3/8" (137mm) W=3-1/4" (83mm) T=2-5/16" (59mm) Weight=8.9oz. (252g)
- 303-85 Aluminum Fiddle Block with Swivel Shackle, Cam and Becket.**  
L=6-7/32" (158mm) W=3-1/4" (83mm) T=2-5/16" (59mm) Weight=9.6oz. (272g)

303-75 and 303-85 feature the **NEW** 70-17 Fast Entry Cam Cleat for easier cam engagement



Sunday 23

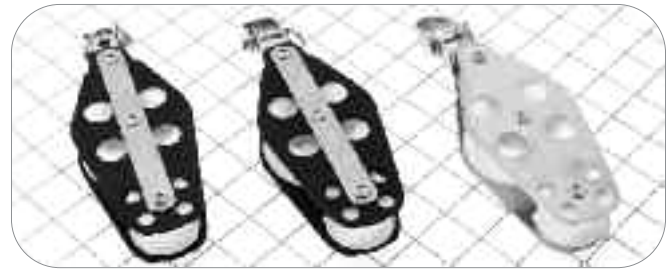

303-43

303-45

03-45

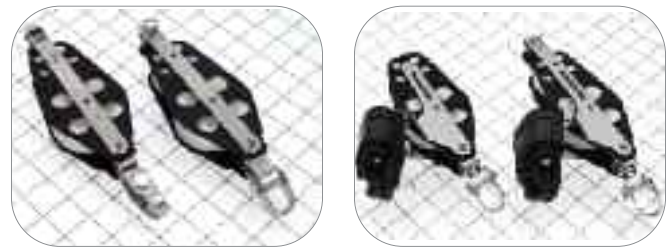

303-53

303-55

303-75

303-85



**Common Specifications**

3 Series Blocks use brilliant Stainless Steel or Tough, Hardcoat Anodized Aluminum cheeks with UV protected Delrin™ sheaves to withstand the elements and potential mishaps far longer than other brands with standard plastic cheeks and sheaves.

**Sheave Diameter:** 1-7/16" (37mm)

**Sheave Width:** 9/16" (14mm)

**Maximum Line Diameter:** 7/16" (11mm)

**Pin Diameter:** 3/16" (5mm)

**SWL Block:** 1000 lbs (410kg)

**SWL Ball Bearing:** 650 lbs (294kg)

**L** - Length

**W** - Width

**T** - Overall Thickness

LEGEND

# 5 Series Blocks

5 Series Blocks offer small to medium-sized cruising and racing yachts an extremely high strength/weight ratio resulting in a highly refined and reliable block. Their strength and styling has also made them popular for medium use on bigger yachts teaming up with our larger Series Blocks.

Our versatile Universal Head design has a three way built in locking feature and accepts "universal" adapters for custom mounting. Schaefer offers you the choice of brilliant Stainless Steel or Hardcoat Anodized Aluminum cheeks with UV protected Delrin™ or Delrin™ Ball Bearing sheaves. 5 Series Blocks provide you with extreme durability and versatility.

Mainsheet Systems	boats to 28' (8.5m)
Halyard Leads	boats to 28' (8.5m)
Genoa Leads	boats to 28' (8.5m)
Control Lines	boats to 36' (11m)



504-05

Three way Swivel head rotates 360°, or can be locked in place with the simple set screw adjustment. See page 13 for our 5 Series Universal Adapters increasing the ability to use your block where you need it.



504-05

504-06

506-05

505-05



504-15

506-15

505-15

504-09



504-25

506-25

505-25



504-35

505-35

## 504-05 Single Aluminum Block.

L=4-13/32" (112mm) W=2-1/8" (54mm) T=15/16" (24mm) Weight=5 oz. (142g)

## 504-06 Single Aluminum Block with Aluminum Sheave.

L=4-13/32" (112mm) W=2-1/8" (54mm) T=15/16" (24mm) Weight=6 oz. (171g)

## 506-05 Single Aluminum Ball Bearing Block.

L=4-13/32" (112mm) W=2-1/8" (54mm) T=15/16" (24mm) Weight=5 oz. (142g)

## 505-05 Single Stainless Block.

L=4-13/32" (112mm) W=2-1/8" (54mm) T=15/16" (24mm) Weight=7.1 oz. (201g)

## 504-15 Single Aluminum Block with Becket.

L=5-17/32" (140mm) W=2-1/8" (54mm) T=15/16" (24mm) Weight=5.7 oz. (162g)

## 505-15 Single Stainless Block with Becket.

L=5-17/32" (140mm) W=2-1/8" (54mm) T=15/16" (24mm) Weight=8.3 oz. (235g)

## 506-15 Single Aluminum Ball Bearing Block with Becket.

L=5-17/32" (140mm) W=2-1/8" (54mm) T=15/16" (24mm) Weight=5.7 oz. (162g)

## 504-09 Single Aluminum Block with Snap Shackle.

L=4-7/8" (124mm) W=2-1/8" (54mm) T=15/16" (24mm) Weight=5.4 oz. (153g)

## 504-25 Double Aluminum Block with Universal, High Strength Head.

L=5-1/16" (129mm) W=2-1/8" (54mm) T=1-21/32" (42mm) Weight=8.3 oz. (235g)

## 505-25 Double Stainless Block with Universal, High Strength Head.

L=5-1/16" (129mm) W=2-1/8" (54mm) T=1-21/32" (42mm) Weight=11.6 oz. (329g)

## 506-25 Double Aluminum Ball Bearing Block with Universal, High Strength Head.

L=5-1/16" (129mm) W=2-1/8" (54mm) T=1-21/32" (42mm) Weight=8.3 oz. (235g)

## 505-35 Double Aluminum Block with Becket and Universal High Strength Head

L=6-3/16" (157mm) W=2-1/8" (54mm) T=1-21/32" (42mm) Weight=12.8 oz (363g)

## 504-35 Double Aluminum Block with Becket and Universal, High Strength Head.

L=6-3/16" (157mm) W=2-1/8" (54mm) T=1-21/32" (42mm) Weight=9.1 oz (258g)

# 5 Series Blocks



505-90



505-93



506-90



506-93

**505-90 Triple Stainless Block.**

L=4-13/32" (112mm) W=2-1/8" (54mm) T=2-3/8" (61mm) Weight=13.5 oz. (383g)

**505-93 Triple Stainless Steel Block with Adjustable Cam, Becket.**

L=5-17/32" (140mm), W=4" (101mm), T=2-5/16" (59mm), Weight 1lb. 3 oz (482g)

**506-90 Triple Aluminum Ball Bearing Block.**

L=4-13/32" (112mm) W=2-1/8" (54mm) T=2-3/8" (61mm) Weight=9.2 oz. (261g)

**506-93 Triple Aluminum Ball Bearing Block with Adjustable Cam, Becket.**

L=5-17/32" (140mm) W=4" (101mm) T=2-5/16" (59mm) Weight=1 lb. 3 oz. (482g)



Damaging UV rays from the sun and knocks from use and abuse can turn an ordinary plastic block into a cracked unusable shell. 5 Series Blocks use brilliant stainless steel or hardcoat anodized cheeks with UV protected Delrin™ Sheaves to withstand the elements and potential mishaps than other brands with plastic cheeks and sheaves

Common Specifications

Cheeks are constructed of tumbled and polished Stainless Steel or Hardcoat Anodized Aluminum for maximum resistance to corrosion and cracking common in Plastic designs. Sheaves are made of high impact Delrin™ or Delrin™ running on Delrin™ Ball Bearings.

**Sheave Diameter:** 2" (51mm)

**Sheave Width:** 9/16" (14mm)

**Maximum Line Diameter:** 7/16" (11mm)

**Pin Diameter:** 1/4" (6mm)

**SWL Aluminum/Stainless:** 1750 lbs (795kg)

**SWL Ball Bearing:** 1500 lbs (680kg)

**L** - Length

**W** - Width

**T** - Overall Thickness

LEGEND

# 5 Series Blocks

Tune your Mainsail with our 5 Series Fiddle Blocks. Strong, smooth and reliable, they offer small to medium sized cruising and racing yachts an ideal solution for mainsheet and boom vang systems.

Choose from brilliant Stainless Steel or Black Hardcoat Anodized Aluminum versions with Delrin™ or Delrin™ Ball Bearing sheaves. Our Universal Three-way head design combined with our Universal adapters solve any challenging setup you have.



504-45      506-45      505-45      504-55      505-55



504-76      504-75      505-75      505-76      506-76

- 504-45 Aluminum Fiddle Block.**  
L=6-7/16" (163mm) W=2-3/8" (60mm) T=15/16" (24mm) Weight=7.3 oz. (207g)
- 505-45 Stainless Fiddle Block.**  
L=6-7/16" (163mm) W=2-3/8" (60mm) T=15/16" (24mm) Weight=11.3 oz. (320g)
- 506-45 Aluminum Ball Bearing Fiddle Block.**  
L=6-7/16" (163mm) W=2-3/8" (60mm) T=15/16" (24mm) Weight=7.3 oz. (207g)
- 504-55 Aluminum Fiddle Block with Becket.**  
L=7-3/16" (183mm) W=2-3/8" (60mm) T=15/16" (24mm) Weight=8 oz. (227g)
- 505-55 Stainless Fiddle Block with Becket.**  
L=7-3/16" (183mm) W=2-3/8" (60mm) T=15/16" (24mm) Weight=11.9 oz. (337g)
- 504-75 Aluminum Fiddle Block with Cam and Becket.**  
L=6-13/32" (163mm) W=3-7/32" (82mm) T=2-5/16" (58mm) Weight=11.6 oz. (329g)
- 505-75 Stainless Fiddle Block with Cam and Becket.**  
L=6-13/32" (163mm) W=3-7/32" (82mm) T=2-5/16" (58mm) Weight=14.9 oz. (422g)
- 506-75 Aluminum Fiddle Block with Ball Bearings, Cam and Becket.**  
L=6-13/32" (163mm) W=3-7/32" (82mm) T=2-5/16" (58mm) Weight=11.6 oz. (329g)
- 504-76 Aluminum Fiddle Block with Adjustable Cam and Becket.**  
L=7-3/16" (183mm) W=4-1/8" (105mm) T=2-5/16" (58mm) Weight=13.6 oz. (386g)
- 505-76 Stainless Fiddle Block with Adjustable Cam and Becket.**  
L=7-3/16" (183mm) W=4-1/8" (105mm) T=2-5/16" (58mm) Weight=1 lb. 2 oz. (510g)



All 5 Series Blocks with Cam Cleats now feature our NEW 70-17 Aluminum Fast Entry Cam Cleat. This new feature will allow faster and easier cam engagement.



504-49      504-51

- 506-76 Aluminum Fiddle Block with Ball Bearings, Adjustable Cam and Becket.**  
L=7-3/16" (183mm) W=4-1/8" (105mm) T=2-5/16" (58mm) Weight=13.6 oz. (386g)
- 504-49 Aluminum Fiddle Block with Snap Shackle Release.**  
L=6-29/32" (175mm) W=2-3/8" (60mm) T=15/16" (24mm) Weight=7.6 oz. (215g)
- 504-51 Aluminum Fiddle Block with Cam and Snap Shackle Release.**  
L=6-3/32" (155mm) W=3-7/32" (82mm) T=2-5/16" (58mm) Weight=11.3 oz. (320g)

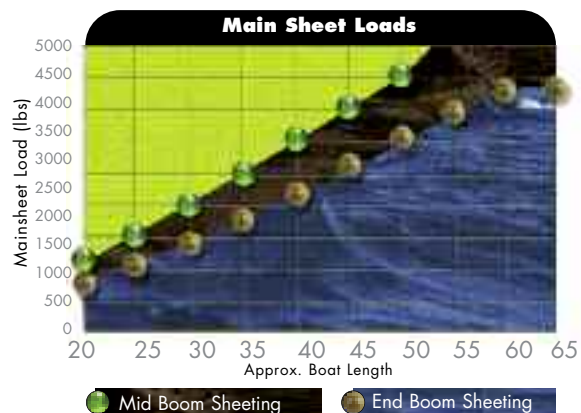

# 5 Series Universal Adapters



Snap Shackle  
504-01



Deck Plate  
504-02



Upset Shackle  
78-50



T-Track Slider  
504-73

All 5 Series Blocks with universal heads can be combined with the following Universal Adapters for custom mounting:

## Universal Adapters

### 504-01 Snap Shackle Adapter

L=2-21/32" (68mm) W=1-9/32" (32mm) Weight=2.5 oz. (71g)

### 504-02 Deck Plate Adapter

Overall Diameter 2-7/8" (73mm) H=1-1/2" (38mm) Center/Center=1-13/32" (36mm), Weight=3.5oz (99g)

### 504-73 T-Track Slider for 1" x 1/8" T-Track

L=3" (76mm) H=1-19/32" (41mm) Weight=3.5oz (99g)

### 78-50 Upset Shackle

Mounts two 5 Series Blocks head to head. 2 oz (57g)

Common Specifications

Cheeks are constructed of tumbled and polished Stainless Steel or Hardcoat Anodized Aluminum for maximum resistance to corrosion and cracking common in Plastic designs. Sheaves are made of high impact Delrin™ or Delrin™ running on Delrin™ Ball Bearings.

**Sheave Diameter:** 2" (51mm)

**Sheave Width:** 9/16" (14mm)

**Maximum Line Diameter:** 7/16" (11mm)

**Pin Diameter:** 1/4" (6mm)

**SWL Aluminum/Stainless:** 1750 lbs (795kg)

**SWL Ball Bearing:** 1500 lbs (680kg)

**L** - Length

**W** - Width

**T** - Overall Thickness

LEGEND

Blocks and rigging should not be put away wet after being immersed in salt water. Fresh water rinsing and cleaning are important maintenance items to prolong proper functioning and usable life of your equipment.



# 7 Series Blocks

7 Series Blocks offer medium sized cruising and racing yachts Delrin™ and Delrin™ Ball Bearing sheave Blocks with a stunning combination of strength and performance. Available with highly polished Stainless Steel or Black Hardcoat Anodized Aluminum cheeks that are reinforced with large Stainless Steel V-Straps and head posts.

This robust yet lightweight construction produces an exceptionally strong block built to perform well past other plastic designs. We use only the toughest, high-impact material available so you'll be sailing while others are fixing failed gear.

All of our 7 Series Blocks work with convenient Universal Adapters and contain our three-way head that allows for free swiveling or front/side set positions.

Mainsheet Systems boats to 34' (10.3m)  
 Halyard Leads boats to 34' (10.3m)  
 Genoa Leads boats to 34' (10.3m)  
 Control Lines boats to 45' (13.7m)

**704-05 Single Aluminum Block.**

L=5-1/32" (128mm) W=2-1/2" (64mm) T=1-3/32" (28mm) Weight=7.4 oz. (210g)

**705-05 Single Stainless Block.**

L=5-1/32" (128mm) W=2-1/2" (64mm) T=1-3/32" (28mm) Weight=10.2 oz. (289g)

**706-05 Single Aluminum Block Ball Bearing Block.**

L=5-1/32" (128mm) W=2-1/2" (64mm) T=1-3/32" (28mm) Weight=7.4 oz. (210g)

**704-06 Single Aluminum Block with Aluminum Sheave.**

L=5-1/32" (128mm) W=2-1/2" (64mm) T=1-3/32" (28mm) Weight=10.2 oz. (289g)

**704-09 Single Aluminum Block with Snap Shackle Release.**

L=5-13/16" (148mm) W=2-1/2" (64mm) T=1-3/32" (28mm) Weight= 8.6 oz. (244g)

**704-15 Single Aluminum Block with Becket.**

L=6-9/32" (160mm) W=2-1/2" (64mm) T=1-3/32" (28mm) Weight=9.0 oz.(255g)

**705-15 Single Stainless Block with Becket.**

L=6-9/32" (160mm) W=2-1/2" (64mm) T=1-3/32" (28mm) Weight=12.7 oz. (360g)

**706-15 Single Aluminum Ball Bearing Block with Becket.**

L=6-9/32" (160mm) W=2-1/2" (64mm) T=1-3/32" (28mm) Weight=9.0 oz.(255g)

**704-25 Double Aluminum Block.**

L=5-27/32" (148mm) W=2-1/2" (64mm) T=2" (51mm) Weight=1 lb 1 oz. (482g)

**705-25 Double Stainless Block.**

L=5-27/32" (148mm) W=2-1/2" (64mm) T=2" (51mm) Weight=12.4 oz. (352g)

**706-25 Double Aluminum Ball Bearing Block.**

L=5-27/32" (148mm) W=2-1/2" (64mm) T=2" (51mm) Weight=12.4 oz. (352g)

**704-35 Double Aluminum Block with Becket.**

L=7-3/32" (180mm) W=2-1/2" (64mm) T=2" (51mm) Weight=14.3 oz. (405g)

**705-35 Double Stainless Block with Becket.**

L=7-3/32" (180mm) W=2-1/2" (64mm) T=2" (51mm) Weight=1 lb. 3 oz. (538g)

**706-35 Double Aluminum Ball Bearing Block with Becket.**

L=7-3/32" (180mm) W=2-1/2" (64mm) T=2" (51mm) Weight=14.3 oz. (405g)



704-05

706-05

705-05

704-06



704-09

704-15

706-15

705-15



704-25

706-25

705-25



704-35

706-35

705-35

# 7 Series Blocks



704-94

705-94

706-94

705-95



704-98

706-98

705-98

"Featuring new 70-27 Aluminum Cam cleat

**704-94 Triple Aluminum Block.**

L=5-1/32" (128mm) W=2-1/2" (64mm) T=2-29/32" (74mm) Weight=14.3 oz. (405g)

**705-94 Triple Stainless Block.**

L=5-1/32" (128mm) W=2-1/2" (64mm) T=2-29/32" (74mm) Weight=1 lb. 4 oz. (567g)

**706-94 Triple Aluminum Ball Bearing Block.**

L=5-1/32" (128mm) W=2-1/2" (64mm) T=2-29/32" (74mm) Weight=14.3 oz. (405g)

**705-95 Triple Stainless Block with Becket.**

L=6-9/32" (160mm) W=2-1/2" (64mm) T=2-29/32" (74mm) Weight=1 lb. 5 oz. (595g)

**704-98 Triple Aluminum Block with Adjustable Cam and Becket.**

L=6-9/32" (160mm) W=4-21/32" (118mm) T=2-29/32" (74mm)  
Weight=1 lb. 11 oz. (765g)

**705-98 Triple Stainless Block with Adjustable Cam and Becket.**

L=6-9/32" (160mm) W=4-21/32" (118mm) T=2-29/32" (74mm)  
Weight=2 lb. 1 oz. (935g)

**706-98 Triple Aluminum Ball Bearing Block with Adjustable Cam.**

L=6-9/32" (160mm) W=4-21/32" (118mm) T=2-29/32" (74mm)  
Weight=1 lb. 11 oz. (765g)

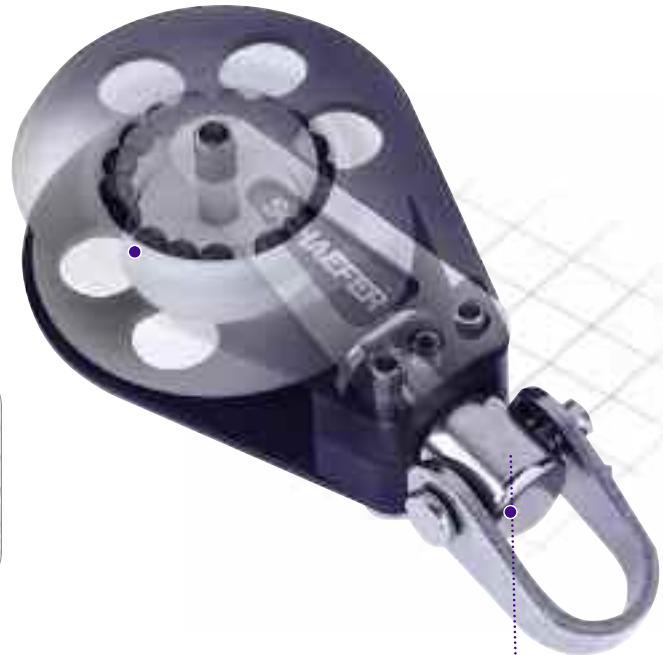

Three way Swivel head rotates 360°, or can be fixed in place with built in locking feature for front or side positions. Head position is determined by a simple set screw adjustment. Loosen for swivel action, tighten for front or side shackle positions. Custom mounting "universal" adapters are easy to use by simply removing the shackle bail and matching with any of the five "plug-in" options.

Common Specifications

Cheeks are constructed of tumbled and polished Stainless Steel or Hardcoat Anodized Aluminum for maximum corrosion resistance and strength. Sheaves are made of high-impact Delrin™ or Delrin™ with Delrin™ Ball Bearings.

**Sheave Diameter:** 2-3/8" (60mm)

**Sheave Width:** 3/4" (19mm)

**Maximum Line Diameter:** 1/2" (13mm)

**Pin Diameter:** 1/4" (6mm)

**SWL Aluminum/Stainless:** 2250 lbs (1020kg)

**SWL Ball Bearing:** 1700 lbs (771kg)

**L** - Length

**W** - Width

**T** - Overall Thickness

LEGEND



# 7 Series Fiddle Blocks

7 Series Fiddle Blocks are constructed with a large diameter single sheave and dual in-line sheaves with the ability to spread oversized line over a greater surface. This high load design offers the ability to withstand the shock loads associated with Mainsheet and Boom Vang Systems. This powerful configuration prevents sheets from crossing and chafing and distributes load to three axles instead of the two seen in other block designs.

Delrin™ or Delrin™ Ball Bearing sheave designs are offered with either high luster Stainless Steel or Hardcoat Anodized Aluminum cheeks. All of our 7 Series Fiddle Blocks work with our Universal Adapters. Spread the load and get control of your main.



## 704-45 Aluminum Fiddle Block.

L=7-15/32" (190mm) W=3-31/32" (101mm) T=1-3/32" (28mm)  
Weight=14.3 oz. (405g)

## 705-45 Stainless Fiddle Block

L=7-15/32" (190mm) W=3-31/32" (101mm) T=1-3/32" (28mm)  
Weight=1 lb. 5 oz. (595g)

## 706-45 Aluminum Ball Bearing Fiddle Block

L=7-15/32" (190mm) W=3-31/32" (101mm) T=1-3/32" (28mm)  
Weight=14.3 oz. (405g)

## 704-55 Aluminum Fiddle Block with Becket.

L=8-25/32" (223mm) W=3-31/32" (101mm) T=1-3/32" (28mm)  
Weight=1 lb. 7 oz. (652g)

## 705-55 Stainless Fiddle Block with Becket.

L=8-25/32" (223mm) W=3-31/32" (101mm) T=1-3/32" (28mm)  
Weight=1 lb. 5 oz. (628g)

## 706-55 Aluminum Ball Bearing Fiddle Block with Becket

L=8-25/32" (223mm) W=3-31/32" (101mm) T=1-3/32" (28mm)  
Weight=1 lb. 7 oz. (652g)

## 704-75 Aluminum Fiddle Block with Becket and Cam.

L=8-25/32" (223mm) W=4" (102mm) T=2-11/16" (68mm)  
Weight=1 lb. 5 oz. (595g)

## 705-75 Stainless Fiddle Block with Becket and Cam.

L=8-25/32" (223mm) W=4" (102mm) T=2-11/16" (68mm) Weight=1 lb. 12 oz. (794g)

## 706-75 Aluminum Ball Bearing Fiddle Block with Becket and Cam.

L=8-25/32" (223mm) W=4" (102mm) T=2-11/16" (68mm) Weight=1 lb. 5 oz. (595g)

## 704-49 Aluminum Fiddle Block with Snap Shackles Release.

L=8-1/4" (210mm) W=3-31/32" (101mm) T=1-3/32" (28mm) Weight=15.3 oz. (434g)

## 704-51 Aluminum Fiddle Block with Cam, Becket and Snap Shackles Release.

L=9-9/16" (243mm) W=4" (102mm) T=2-11/16" (68mm) Weight=1 lb. 6 oz. (624g)



704-45

706-45

705-45



704-55

706-55

705-55



704-75

706-75

705-75



704-49

704-51

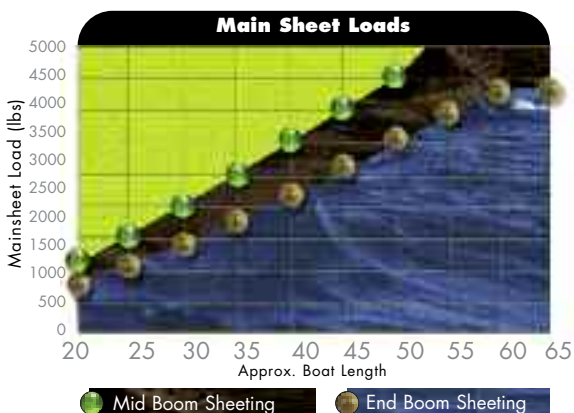

# 7 Series Universal Adapters



704-01



704-02



704-12



704-73



78-70

## Universal Adapters

Schaefer's 7 Series Universal Adapters allow you the flexibility to custom mount our blocks to your needs.

### 704-01 Snap Shackle Adapter.

Weight=4.5 oz.(128g) L=3-9/32" (83mm) W=1-5/8" (41mm)

### 704-02 Deck Plate.

Weight=7.5 oz (213g) Overall Dia.=3-3/8" (86mm) H=1-15/16" (49mm)  
C/C=1-11/16" (43mm)

### 704-12 Screw Plug.

Use with #78-81 Deck plate for removable system.Weight=4.5 oz. (128g)

### 704-73 Universal Slide for 1-1/4" "T" Track.

T-Track Slider Weight=9 oz. (255g) L=4" (102mm) H=2-5/32" (55mm)

### 78-70 Upset Shackle.

Mounts two 7 Series Blocks head-to-head. Weight=2 oz. (57g)

### 78-81 Deck Plate. (See Page 68)

Screw Plug Base accepts 704-12 screw plug. Weight=6 oz.(170g) L=2-1/2" Dia. (64mm)

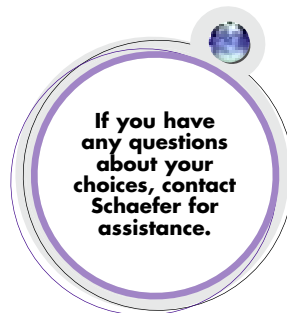

## Common Specifications

Cheeks are constructed of tumbled and polished Stainless Steel or Hardcoat Anodized Aluminum for maximum corrosion resistance and strength. Sheaves are made of high-impact Delrin™ or Delrin™ with Delrin™ Ball Bearings.

**Sheave Diameter:** 2-3/8" (60mm)

**Sheave Width:** 3/4" (19mm)

**Maximum Line Diameter:** 1/2" (13mm)

**Pin Diameter:** 1/4" (6mm)

**SWL Aluminum/Stainless:** 2250 lbs (1020kg)

**SWL Ball Bearing:** 1700 lbs (771kg)

**L** - Length

**W** - Width

**T** - Overall Thickness

LEGEND

# 8 Series Stainless Steel Blocks

Schaefer's 8 Series Stainless Blocks add strength and brilliance to your deck. Featuring Delrin™ sheaves, forged stainless steel "D" shackles, bolted construction for strength and Stainless Steel cheeks polished to a high luster add beauty and confidence to your boat.

All 8 Series blocks feature our high-strength, low-friction Nomen™/Teflon™ bearing for smooth operation under the toughest of conditions

Mainsheet Systems boats to 42' (12.8m)  
 Halyard Leads boats to 42' (12.8m)  
 Genoa Leads boats to 42' (12.8m)  
 Control Lines boats to 52' (15.8m)



08-05

08-05-UC



08-15

08-15-UC

## 08-05 Stainless Single Block.

L=5-5/8" (143mm) W=2-3/8" (60mm) T=1-3/32" (28mm) Weight=12 oz. (340g)

## 08-05-UC Stainless Single Block with UC Sheave.

L=5-5/8" (143mm) W=2-3/8" (60mm) T=1-3/32" (28mm) Weight=13.8 oz. (391g)  
 Universal Circuit Ball Bearing Sheave for Wire/Rope

## 08-15 Stainless Single Block with Becket.

L=7" (178mm) W=2-3/8" (60mm) T=1-3/32" (28mm) Weight=13.4 oz. (380g)

## 08-15-UC Stainless Single Block with UC Sheave and Becket.

L=7" (178mm) W=2-3/8" (60mm) T=1-3/32" (28mm) Weight=15.5oz. (439g)  
 Universal Circuit Ball Bearing Sheave for Wire/Rope

## 08-45 Stainless Fiddle Block.

L=8-1/8" (207mm) W=3-31/32" (101mm) T=1-3/32" (28mm) Weight=1 lb. 7 oz. (652g)

## 08-55 Stainless Fiddle Block with Becket

L=9-7/16" (240mm) W=3-31/32" (101mm) T=1-3/32" (28mm) Weight=1 lb. 9 oz. (709g)

## 23-55 Stainless Fiddle Block with Cam and Becket.

L=9-7/16" (240mm) W=4" (102mm) T=2-11/16" (68mm) Weight=1 lb. 13 oz. (822g)



08-45



23-55

### Common Specifications

Cheeks are constructed of tumbled and polished Stainless Steel or Hardcoat Anodized Aluminum. Sheaves are made of Injection molded Delrin™ with Nomex™/Teflon™ bearings or Aluminum utilizing Delrin™ Ball Bearings and our Nomex™/Teflon™ bearing.

**Sheave Diameter:** 2-3/8" (60mm)

**Sheave Width:** 13/16" (21mm)

**Maximum Line Diameter:** 9/16" (14mm)

**Max Wire (UC only):** 3/16" (5mm)

**Pin Diameter:** 5/16" (8mm)

**SWL:** 2750 lbs (1250kg)

**L** - Length

**W** - Width

**T** - Overall Thickness

LEGEND

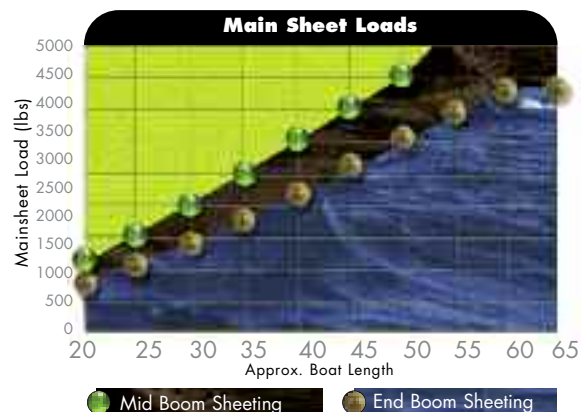

# 10 Series Blocks

Schaefer's 10 Series Blocks feature Stainless Steel cheeks, forged "D" Shackles, Universal Head swivels, Stainless Steel straps for exceptional strength and your choice of either Lexan or our High Performance "UC" sheaves. Lexan sheaves use our Nomex™/Teflon™ bearings for high strength and a low-friction bearing surface. "UC" sheaves use this bearing as well as a self-contained circuit of Delrin™ ball bearings for a very smooth and strong block. Available in a variety of styles to solve any lead issue you may have.

- Mainsheet Systems boats to 46' (14m)
- Halyard Leads boats to 46' (14m)
- Genoa Leads boats to 46' (14m)
- Control Lines boats to 60' (18.3m)



10-05



10-05-UC



10-15



10-15-UC

**If you have any questions about your choices, contact Schaefer for assistance.**

- 10-05 Stainless Single Block.**  
L=6-19/32" (167mm) W=3-1/4" (83mm) T=1-7/32" (31mm) Weight=1 lb. 11 oz. (765g)
- 10-05-UC Stainless Single Block with UC Sheave.**  
L=6-19/32" (167mm) W=3-1/4" (83mm) T=1-7/32" (31mm) Weight=1 lb. 11 oz. (765g)
- 10-15 Stainless Single Block with Becket.**  
L=8-19/32" (218mm) W=3-1/4" (83mm) T=1-7/32" (31mm) Weight=1 lb. 10 oz. (737g)
- 10-15-UC Stainless Single Block with UC Sheave and Becket.**  
L=8-19/32" (218mm) W=3-1/4" (83mm) T=1-7/32" (31mm) Weight=1 lb. 10 oz. (737g)

**Common Specifications**

Cheeks are constructed of tumbled and polished Stainless Steel or Hardcoat Anodized Aluminum. Sheaves are made of Lexan® with Nomex™/Teflon™ bearings or Aluminum utilizing Delrin™ Ball Bearings and our Nomex™/Teflon™ bearing.

- Sheave Diameter:** 3-1/4" (83mm)
- Sheave Width:** 13/16" (21mm)
- Maximum Line Diameter:** 5/8" (16mm)
- Max Wire:** 1/4" (6mm)
- Pin Diameter:** 3/8" (10mm)
- SWL:** 3750 lbs (1750kg)

**L** - Length LEGEND  
**W** - Width  
**T** - Overall Thickness



10-45



10-55

- 10-45-UC Stainless Fiddle Block with UC Sheave.**  
L=9-1/4" (235mm) W=4-13/16" (122mm) T=1-7/32" (31mm)  
Weight=3 lbs. 1 oz. (1.39kg)
- 10-55 Stainless Fiddle Block with Becket.**  
L=11-1/4" (286mm) W=4-13/16" (122mm) T=1-7/32" (31mm)  
Weight=3 lbs. 4 oz. (1.47kg)
- 10-55-UC Stainless Fiddle Block with UC Sheave and Becket.**  
L=11-1/4" (286mm) W=4-13/16" (122mm) T=1-7/32" (31mm)  
Weight=3 lbs. 4 oz. (1.47kg)



Cheeks of Tumbled and Polished Stainless Steel provide an elegant and extremely strong block. Machined Aluminum sheaves run on our Nomex™/Teflon™ bearing and utilize Delrin™ Ball Bearings for low friction leads.

Forged Stainless Steel Shackles on Universal Heads provide superior strength and allow for various mounting applications. The 5000 lb. SWL continues the legendary strength of Schaefer Marine products.

120-05-UC  
Shown Actual Size

**SCHAEFER**  
LEGENDARY STRENGTH

# 12 Series Blocks

12 Series Blocks, contain powerful 4" diameter sheaves to handle the loads generated by large "offshore" yachts. Highly polished Stainless Steel cheeks are reinforced with Stainless Steel V-Straps for strength and durability under load.

Precision machined Aluminum sheaves are scored for line or wire and feature our self-contained Universal Circuit package with the Nomex™/Teflon™ composite bearing and twin bearing races for maximum thrust load capacity. Powerful, oversized sheaves and Schaefer's distinctive qualities ensure that you get the lasting quality you need.

Mainsheet Systems	boats to 60' (18.3m)
Halyard Leads	boats to 60' (18.3m)
Genoa Leads	boats to 60' (18.3m)
Control Lines	Consult Schaefer



120-05-UC



120-15-UC



120-45-UC



120-55-UC

- 120-05-UC Stainless Single Block.**  
L=8-9/32" (210mm) W=4" (102mm) T=1-1/2" (38mm) Weight=2 lbs. 13 oz. (1.28kg)
- 120-15-UC Stainless Single Block with Becket.**  
L=9-25/32" (248mm) W=4" (102mm) T=1-1/2" (38mm) Weight=3 lbs. 1 oz. (1.39kg)
- 120-45-UC Stainless Fiddle Block.**  
L=11-9/32" (286mm) W=4" (102mm) T=1-1/2" (38mm) Weight=4 lbs. 1 oz. (1.84kg)
- 120-55-UC Stainless Fiddle Block with Becket.**  
L=12-23/32" (323mm) W=4" (102mm) T=1-1/2" (38mm) Weight=4 lbs 4 oz. (1.93kg)

**Common Specifications**

Cheeks are constructed of tumbled and polished Stainless Steel or Hardcoat Anodized Aluminum. Sheaves are computer machined Aluminum Ball Bearing "UC" sheave for line or wire running using our Nomex™/Teflon™ Bearing.

**Sheave Diameter:** 4" (102mm)  
**Sheave Width:** 1-1/32" (26mm)  
**Maximum Line Diameter:** 3/4" (19mm)  
**Maximum Wire Size:** 5/16" (8mm)  
**Pin Dia.:** 7/16" (12mm)  
**SWL:** 5000 lbs (2270 kg)

**L** - Length  
**W** - Width  
**T** - Overall Thickness  
 Stainless with UC Sheave

LEGEND



# Wire / Utility Blocks

Choose from our standard Wire Blocks with narrow heads and sheaves or our Eye-Jaw Wire blocks. Either are perfect for use with Control Lines or Halyards. Stainless cheeks offer high abrasion and chafe resistance as well as opening to accept swaged or micro pressed wires. Eye Jaw Wire Blocks are easy to use with Runners, Backstays or any area requiring strong wire support. They also use our Nomex™ / Teflon™ Bearing for high load / low friction application.



33-02



33-03



33-05



33-20



33-30



33-40

Item	Descrip./ Sheave	Sheave Dia.	Max Wire	Jaw Opening	Pin Dia.	L	W	T	SWL	Weight
33-02	Wire/ Bronze	1-1/16" (27mm)	1/8" (3mm)	---	3/16" (5mm)	2-19/32" (66mm)	1-3/16" (30mm)	3/8" (9mm)	900 lbs. (410kg)	1.75 oz. (50g)
33-03	Wire/ Alum.	1-7/16" (37mm)	1/8" (3mm)	---	3/16" (5mm)	2-15/16" (74mm)	1-9/16" (40mm)	13/32" (10mm)	1000 lbs. (453kg)	2 oz. (57g)
33-05	Wire/ Alum.	2" (51mm)	3/16" (5mm)	---	1/4" (6mm)	3-25/32" (96mm)	2-1/8" (54mm)	17/32" (14mm)	1750 lbs. (795kg)	3 oz. (85g)
33-20	Eye Jaw/ Alum.	2-3/8" (60mm)	1/8" (3mm)	13/32" (10mm)	3/8" (10mm)	4-27/32" (123mm)	2-3/8" (60mm)	17/32" (13mm)	4000 lbs. (1815kg)	10 oz. (284g)
33-30	Eye Jaw/ Alum.	3-1/4" (83mm)	3/16" (5mm)	17/32" (14mm)	1/2" (12mm)	6-11/32" (161mm)	3-1/4" (83mm)	25/32" (20mm)	5500 lbs. (2495kg)	1 lb. 7 oz. (652kg)
33-40	Eye Jaw/ Alum.	4" (102mm)	1/4" (6mm)	11/16" (18mm)	5/8" (16mm)	7-17/32" (191mm)	4" (102mm)	15/16" (24mm)	7500 lbs. (3402kg)	2 lb. 8 oz. (1.13kg)

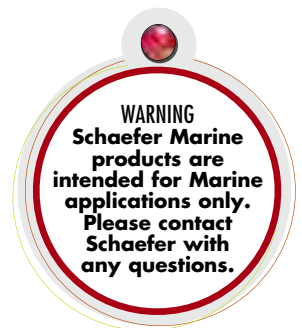

# Wire / Utility Blocks

Schaefer offers several utility and Collar Post blocks to solve a variety of lead problems. Our Utility style blocks offer a removable Ferrule design for quick and strong attachment to a variety of fittings. The 505-20 and 705-20 include a collar post and our M66-20 and M82-20 offer an easy attachment to existing mast collars. All of Schaefer's utility blocks are ideal for high static loads created at the base of the mast.



505-20



705-20



504-38



704-38



M66-38



M82-38



M66-20



M82-20

Our 704-38 Utility Block with Delrin™ sheaves are designed for use with line only. Under no circumstance should these utility blocks be used with wire as danger or personal injury may result.

Contact Schaefer for specific product recommendations.

Item	Descrip./ Sheave	Sheave Dia.	Max Line	Pin Diameter	L	W	T	SWL	Weight
M66-20	Mast Collar	2-5/8" (66mm)	1/2" (12mm)	1/4" (6.35mm)	4" (102mm)	2-5/8" (66mm)	1-1/4" (32mm)	1700 lbs. (770kg)	5.6 oz. (158g)
M66-38	Pad Eye	2-5/8" (66mm)	1/2" (12mm)	5/16" (8mm)	4" (102mm)	2-5/8" (66mm)	1-1/4" (32mm)	2800 lbs. (1270kg)	5.7 oz. (161g)
M82-20	Mast Collar	3-7/32" (82mm)	5/8" (16mm)	5/16" (8mm)	5" (127mm)	3-7/32" (82mm)	1-7/16" (36mm)	3 000 lbs. (1360kg)	8.8 oz. (249g)
M82-38	Pad Eye	3-7/32" (82mm)	5/8" (16mm)	3/8" (10mm)	5" (127mm)	3-7/32" (82mm)	1-7/16" (36mm)	5,000 lbs. (2270kg)	8.9 oz. (252g)
505-20	Mast Collar Delrin™	2" (51mm)	7/16" (11mm)	.510 Hole	3-3/32" (79mm)	2-1/8" (54mm)	13/16" (21mm)	1750 lbs. (795kg)	7.1 oz. (201g)
505-38	Utility/Alum.	2" (51mm)	7/16" (11mm)	1/4" (6mm)	3-3/32" (79mm)	2-1/8" (54mm)	13/16" (21mm)	1750 lbs. (795kg)	4 oz. (113g)
504-38	Utility/Delrin™	2" (51mm)	7/16" (11mm)	1/4" (6mm)	3-3/32" (79mm)	2-1/8" (54mm)	13/16" (21mm)	1750 lbs. (795kg)	3.5 oz. (99g)
705-20	Mast Collar Delrin™	2-3/8" (60mm)	1/2" (13mm)	.510 Hole	3-23/32" (94mm)	2-1/2" (64mm)	1" (25mm)	2250 lbs. (1020kg)	1 lb. 3 oz. (539g)
705-38	Utility/Alum.	2-3/8" (60mm)	1/2" (13mm)	1/4" (6mm)	3-23/32" (94mm)	2-1/2" (64mm)	1" (25mm)	2250 lbs. (1020kg)	7 oz. (198g)
704-38	Utility/Delrin™	2-3/8" (60mm)	1/2" (13mm)	1/4" (6mm)	3-23/32" (94mm)	2-1/2" (64mm)	1" (25mm)	2250 lbs. (1020kg)	6.5 oz. (184g)

505-20 and 705-20 fit Isomat Mast Collars with a .510" Hole Diameter. 505-20, 505-38, 705-20 and 705-38 have stainless steel cheeks  
504-38 and 704-38 have aluminum cheeks



# Halyard / Control Blocks

Excellent for fixed position halyard, sheet or control line fairleads. Block swivels 360°, tilts in all directions and is supported by a heavy gauge S.S. sprint to prevent deck contact. Large diameter base helps distribute loads to a larger surface area than other smaller designs.

New M-Series style feature Aluminum sheaves with Teflon™ rollers and Delrin™ ball bearings for superior strength and low-friction. Machined center allows the hub to be used as a becket.



M66-62

M82-62

M100-62



303-62

300-62

03-62



504-62

505-62

506-62



704-62

705-62

706-62

Item Stain.	Item Alum.	Ball Bearing	Descrip.	Backing Plate	Sheave Dia.	Max Line	D***	H	H2	Fastener Size	C/C	SWL	Weight Stain.	Weight Alum.
02-62	---	---	Stand-Up Swivel	97-60	1-1/16" (27mm)	5/16" (8mm)	2" (51mm)	3-5/32" (81mm)	2-5/32" (55mm)	(4)#10 RH (5mm)	1-1/32" (26mm)	900 lbs. (410kg)	2.7 oz. (76g)	3.3 oz. (94g)
03-62	303-62	300-62	Stand-Up Swivel	97-60	1-7/16" (37mm)	7/16" (11mm)	2" (51mm)	3-17/32" (89mm)	2-5/32" (55mm)	(4)#10 RH (5mm)	1-1/32" (26mm)	1000 lbs. (450kg)	3.5 oz. (99g)	3.1 oz. (88g)
505-62	504-62	506-62**	Stand-Up Swivel	97-48	2" (51mm)	7/16" (11mm)	2-7/8" (73mm)	4-1/32" (103mm)	2-3/32" (54mm)	(4)#10 RH (5mm)	1-13/32" (36mm)	1750 lbs. (790kg)	9 oz. (255g)	7.0 oz. (198g)
705-62	704-62	706-62**	Stand-Up Swivel	97-49	2-3/8" (60mm)	1/2" (13mm)	3-3/8" (86mm)	4-25/32" (120mm)	2-15/32" (63mm)	(4)1/4" RH (6mm)	1-11/16" (43mm)	2250 lbs. (1020kg)	14.5 oz. (411g)	11.7 oz. (332g)
08-62	09-62	---	Stand-Up Swivel	97-49	2-3/8" (60mm)	9/16" (14mm)	3-3/8" (86mm)	4-21/32" (118mm)	2-15/32" (63mm)	(4)1/4" RH (6mm)	1-11/16" (43mm)	2750 lbs. (1250kg)	15.8 oz. (448g)	13.3 oz. (337g)
10-62-UC*	---	---	Stand-Up Swivel	97-50	3-1/4" (83mm)	*5/8" (16mm)	4-1/2" (114mm)	6-3/32" (155mm)	3-1/8" (79mm)	(4)5/16" RH (8mm)	2-5/16" (58mm)	3750 lbs. (1700kg)	2 lbs. 6.5 oz. (1.09kg)	2 lbs. (907g)
	M66-62		Stand-Up Swivel	97-36	2-5/8" (66mm)	1/2" (12mm)	2-3/8" (60mm)	5-1/8" (130mm)	2-3/4" (70mm)	(4)1/4" FH (6mm)	1-3/16" (30mm)	2800 lbs. (1270kg)		10.4 oz. (295gm)
	M82-62		Stand-Up Swivel	97-37	3-7/32" (82mm)	5/8" (16mm)	2-7/8" (73mm)	6-1/4" (161mm)	3-1/4" (83mm)	(4)5/16" FH (8mm)	1-3/8" (35mm)	5000 lbs. (2270kg)		19.2 oz. (544gm)
	M100-62		Stand-Up Swivel	97-38	4" (100mm)	3/4" (19mm)	3-5/8" (92mm)	7-1/2" (190mm)	4" (100mm)	(4)3/8" FH (10mm)	1-7/8" (35mm)	7500 lbs. (3410kg)		40.1 oz. (1.14kg)

\* Contains Aluminum, Ball Bearing "UC" Sheave scored for line or wire \*\* 506-62 SWL 1500 lbs, 706-62 SWL 1700 lb \*\*\* Dia. includes urethane base  
 Delrin™ base for 5 Series = 35-018. Delrin™ base for 7,8,9 Series = 35-019. Delrin™ base for 10,11 Series = 35-091-B

# Halyard / Control Blocks



## Halyard Lead Blocks

Lead your halyards aft safely and smoothly with our M-Series Lead blocks. Machined Aluminum cage design follows high-load patterns for a very strong yet light block. Aluminum sheave runs on a Nomex™/Teflon™ bearing and includes Delrin™ ball bearings keeping friction to a minimum.



M66-31                      M82-31                      M100-31

Item	Descrip.	Backing Plate	Sheave Dia.	Max Line	H	Bearing Height	L	W	Fastener	SWL	Weight
M66-31	Halyard Lead	97-39	2-5/8" (66mm)	1/2" (12mm)	3-1/4" (82mm)	7/8" (22mm)	4-1/8" (105mm)	1-3/8" (35mm)	(3) 1/4" FH (6mm)	2800 lbs. (1270kg)	8.5 oz. (241gm)
M82-31	Halyard Lead	97-40	3-7/32" (82mm)	5/8" (16mm)	4-1/8" (105mm)	1" (25mm)	5-1/8" (130mm)	1-1/2" (38mm)	(4) 5/16" FH (8mm)	5000 lbs. (2270kg)	15oz. (425gm)
M100-31	Halyard Lead	97-41	4" (100mm)	3/4" (19mm)	4-7/8" (124mm)	1" (25mm)	6-3/8" (161mm)	1-7/8" (48mm)	(4) 3/8" FH (10mm)	7500 lbs. (3410kg)	26.5oz. (754gm)

Lead halyards, topping lift and other control lines aft with ease. Block is mounted to Bisect halyard load angle for maximum tensile strength.



03-50



504-60



704-60



506-60

Item	Descrip./ Sheave	Sheave Dia.	Max Wire	L	W	H	Bearing Height	Fastener	C/C Length	C/C Across	SWL Length	Weight Across
02-50*	Halyrd. Lift/ Delrin™	1-1/16" (27mm)	5/16" (8mm)	1-9/32" (35mm)	1-13/32" (35mm)	1-11/16" (43mm)	21/32" (17mm)	(4) #10 RH (5mm)	1" (25mm)	1" (25mm)	900 lbs. (410kg)	2.2 oz (62g)
03-50*	Halyrd. Lift/ Delrin™	1-7/16" (37mm)	7/16" (11mm)	1-3/4" (44mm)	1-5/8" (41mm)	1-31/32" (50mm)	19/32" (15mm)	(4) #10 RH (5mm)	1-5/32" (29mm)	1-5/16" (33mm)	1000 lbs. (454kg)	3.5 oz. (99g)
303-50	Halyrd. Lift/ Delrin™	1-7/16" (37mm)	7/16" (11mm)	1-3/4" (44mm)	1-5/8" (41mm)	1-31/32" (50mm)	19/32" (15mm)	(4) #10 RH (5mm)	1-5/32" (29mm)	1-5/16" (33mm)	1000 lbs. (454kg)	3 oz. (85g)
504-60	Halyrd. Lift/ Delrin™	2" (51mm)	7/16" (11mm)	2-9/32" (58mm)	1-5/16" (49mm)	2-9/16" (65mm)	5/8" (16mm)	(4) #10 RH (5mm)	1-21/32" (42mm)	1-13/32" (35mm)	1750 lbs. (795kg)	5.5 oz. (156g)
506-60	Halyrd. Lift/ Delrin™ BB	2" (51mm)	7/16" (11mm)	2-9/32" (58mm)	1-5/16" (49mm)	2-9/16" (65mm)	5/8" (16mm)	(4) #10 RH (5mm)	1-21/32" (42mm)	1-13/32" (35mm)	1500 lbs. (680kg)	5.5 oz (156g)
704-60	Halyrd. Lift/ Delrin™	2-3/8" (60mm)	5/8" (16mm)	2-9/16" (65mm)	2-11/32" (59mm)	3-3/16" (81mm)	15/16" (24mm)	(4) 1/4" RH (6mm)	1-15/16" (49mm)	1-3/4" (44mm)	2250 lbs. (1020kg)	8.1 oz. (230g)

\*Stainless Steel Cheeks

# Halyard / Control Blocks

## Fixed/Hinged Fairlead Blocks

Extremely low profile keeps control lines and halyards close to the deck. Open Delrin™ ball bearing race design guarantees low friction and easy maintenance. Choose from either fixed or hinged models.



200-31



300-31

Item	Descrip. Sheave	Sheave Dia.	Max Line	L	W	H	Bearing Height	Fasteners	C/C	SWL	Weight
200-31	Fxd. Fairlead/ Ball Bearing	1-1/16" (27mm)	5/16" (8mm)	1-5/8" (41mm)	19/32" (15mm)	1-17/32" (39mm)	9/16" (14mm)	(2) #10 RH (5mm)	1-1/4" (32mm)	500 lbs. (225kg)	1.0 oz. (28g)
300-31	Fxd. Fairlead/ Ball Bearing	1-7/16" (27mm)	7/16" (11mm)	2-7/32" (56mm)	3/4" (19mm)	1-31/32" (50mm)	5/8" (16mm)	(2) #10 RH (5mm)	1-3/4" (44mm)	1000 lbs. (454kg)	2.2 oz. (62g)
506-31	Fxd. Fairlead/ Ball Bearing	2" (51mm)	7/16" (11mm)	3" (76mm)	13/16" (21mm)	2-17/32" (64mm)	23/32" (18mm)	(2) 1/4" RH (6mm)	2-1/4" (57mm)	1000 lbs. (454kg)	4.3 oz. (122g)
200-32	Hinged Fairlead/ Ball Bearing	1-1/16" (27mm)	5/16" (8mm)	2-1/8" (54mm)	5/8" (16mm)	1-13/16" (45mm)	3/4" (19mm)	(2) #10 RH (5mm)	1" (25mm)	500 lbs. (225kg)	2.2 oz. (62g)
300-32	Hinged Fairlead/ Ball Bearing	1-7/16" (37mm)	7/16" (11mm)	2-15/32" (63mm)	3/4" (19mm)	2-7/32" (19mm)	7/8" (56mm)	(2) #10 FH (5mm)	1-3/4" (44mm)	650 lbs. (295kg)	3.6 oz. (102g)
506-32	Hinged Fairlead/ Ball Bearing	2" (51mm)	7/16" (11mm)	3-1/4" (83mm)	7/8" (22mm)	3-1/16" (78mm)	1-3/16" (30mm)	(2) 1/4" FH (6mm)	2-1/8" (54mm)	1000 lbs. (454kg)	7.3 oz. (207g)



506-31



200-32



300-32



506-32

## Half-Moon Mast Base Blocks

Our Half-Moon Base Blocks provide a strong and smooth option for leading your halyards and control lines to the cockpit. Choose from four different models, all featuring a heavy duty S.S. cage, polished and buffed to a mirror finish. Sheaves are machined aluminum and run on our self-lubricating Nomex™/Teflon™ Bearing. UC models incorporate Delrin™ Ball Bearings for additional friction reduction.



32-06 / 32-06-UC



32-15-UC

Item	Descrip. Sheave	Sheave Dia.	Max Line	L	W	H	Bearing Height	Fasteners	C/C	SWL	Weight
32-06 32-06-UC	Half-Moon/ Fixed/Alum.	2-3/8" (60mm)	5/8" * (16mm)	3-5/16" (100mm)	1-5/8" (41mm)	3-5/32" (80mm)	25/32" (20mm)	(2) 1/4" RH (6mm)	3" (76mm)	3000 lbs. (1361kg)	11.3 oz. (320g)
32-15-UC	Half-Moon/ Hinged/Alum.	2-3/8" (60mm)	5/8" * (16mm)	4" (102mm)	1-3/4" (44mm)	4" (102mm)	1-5/8" (41mm)	(4) 1/4" RH (6mm)	3" (76mm)	3000 lbs. (1361kg)	15 oz. (425g)
32-17	Half-Moon/ Hinged/Alum.	2-3/8" (60mm)	3/8" * (10mm)	4-5/8" (118mm)	3/4" (19mm)	3-3/16" (97mm)	1-7/16" (37mm)	(4) 1/4" RH (6mm)	3-15/16" (84mm)	3000 lbs. (1361kg)	14.5 oz. (411g)

\*Max wire = 3/16" (5mm)

# Deck Organizers

Help organize your lines and lower the stress in your cockpit with our low-profile, high strength Deck Organizers. Available in many combinations, and in either a brilliant Stainless Steel or Black Hardcoat anodized finish. Perfectly suited to work with our wide variety of Control Lead Blocks.



**Deck Organizer 705-80**

**Deck Organizer 704-81**



303-80

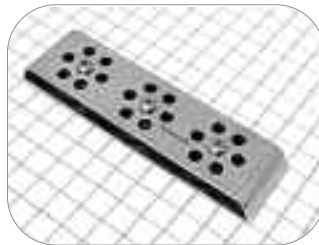

505-81



504-31

**If you have any questions about your choices, contact Schaefer for assistance.**



504-30



704-80

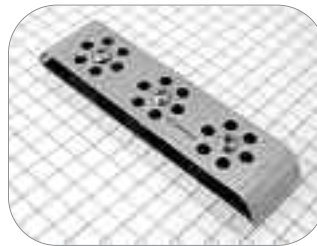

705-81

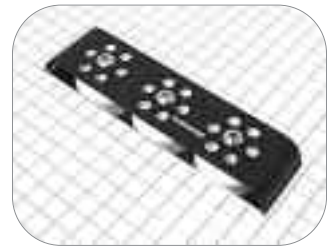

704-81

Item Stain.	Item Alum.	Descrip.	Sheave Dia.	Max Line	L	W	H	Fasteners	C/C	SWL	Weight Stain.	Weight Alum.
---	303-80	Organizer Double	1-7/16" (37mm)	7/16" (11mm)	4-11/32" (110mm)	1-7/16" (37mm)	25/32" (20mm)	(2) 1/4" RH (6mm)	1-5/8" (41mm)	1250 lbs. (567kg)	---	5.4 oz. (153g)
---	303-81	Organizer Triple	1-7/16" (37mm)	7/16" (11mm)	5-31/32" (151mm)	1-7/16" (37mm)	25/32" (20mm)	(3) 1/4" RH (6mm)	1-5/8" (41mm)	1250 lbs. (567kg)	---	7.6 oz. (215g)
505-80	504-80	Organizer Double	2" (51mm)	7/16" (11mm)	5-3/4" (146mm)	2" (51mm)	13/16" (20mm)	(2) 1/4" RH (6mm)	2-1/4" (57mm)	1950 lbs. (885kg)	11.8 oz. (334g)	9.5 oz. (269g)
505-81	504-81	Organizer Triple	2" (51mm)	7/16" (11mm)	7-31/32" (202mm)	2" (51mm)	13/16" (20mm)	(3) 1/4" RH (6mm)	2-1/4" (57mm)	1950 lbs. (885kg)	1 lb. 1 oz. (482g)	13.4 oz. (380g)
---	504-30	2 over 2	2" (51mm)	7/16" (11mm)	5-25/32" (145mm)	2" (51mm)	1-1/2" (38mm)	(2) 1/4" RH (6mm)	2-1/4" (57mm)	1950 lbs. (885kg)	---	15.9 oz. (451g)
---	504-31	3 over 3	2" (51mm)	7/16" (11mm)	7-31/32" (202mm)	2" (51mm)	1-1/2" (38mm)	(3) 1/4" RH (6mm)	2-1/4" (57mm)	1950 lbs. (885kg)	---	1 lb. 6.8 oz. (646g)
705-80	704-80	Organizer Double	2-3/8" (60mm)	1/2" (13mm)	6-31/32" (177mm)	2-3/8" (60mm)	1" (25mm)	(2) 5/16" RH (8mm)	2-3/4" (70mm)	3000 lbs. (1365kg)	1 lb. 4.4 oz. (578g)	15.5 oz. (439g)
705-81	704-81	Organizer Triple	2-3/8" (60mm)	1/2" (13mm)	9-23/32" (247mm)	2-3/8" (60mm)	1" (25mm)	(3) 5/16" RH (8mm)	2-3/4" (70mm)	3000 lbs. (1365kg)	1 lb. 12.6 oz. (811g)	1 lb. 5.8 oz. (618g)
---	704-30	2 over 2	2-3/8" (60mm)	1/2" (13mm)	7" (177mm)	2-3/8" (60mm)	1-29/32" (48mm)	(2) 5/16" RH (8mm)	2-3/4" (70mm)	3000 lbs. (1365kg)	---	1 lb. 11 oz. (765g)
---	704-31	3 over 3	2-3/8" (60mm)	1/2" (13mm)	9-3/4" (247mm)	2-3/8" (60mm)	1-29/32" (48mm)	(3) 5/16" RH (8mm)	2-3/4" (70mm)	3000 lbs. (1365kg)	---	2 lbs. 5.2 oz. (1.05kg)

Aluminum sheaves available for 5 & 7 series organizers. 5 series sheave part # 62-023-15CW. 7 series sheave part # 62-070-BW. Contact Schaefer for more information.

**Call 508-995-9511 for Customer Service**

**SCHAEFER**  
LEGENDARY STRENGTH

# Flat & Curved Base Cheek Blocks

## Flat Base Cheek Blocks

Flat, stainless base plate distributes loads to a larger surface area than other designs that place loads on mounting bolts only. Use on spars and deck to lead sheets, halyards, reefing gear, and any control requiring a strong, smooth lead.

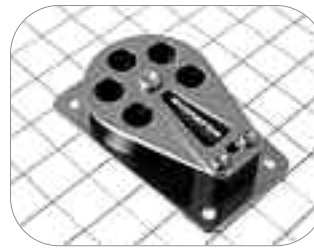

30-27



504-11



706-11



504-28



705-10

Item Stain.	Item Alum.	Item Ball Brg.	Descrip.	Sheave Dia.	Max Line	L	W	H	Fasteners	C/C	SWL	Weight Stain.	Weight Alum.
30-27	303-09	300-09	Flat Base/Sngl/Delrin™	1-7/16" (37mm)	7/16" (11mm)	2-7/8" (73mm)	1-3/4" (44mm)	3/4" (19mm)	(4) #10 RH (5mm)	2-3/8" (60mm)	1000 lbs. (450kg)	2.6 oz. (74g)	2.5 oz. (71g)
---	303-29	---	Flat Base/Dbl/Delrin™	1-7/16" (37mm)	7/16" (11mm)	2-7/8" (73mm)	1-3/4" (44mm)	1-7/16" (37mm)	(4) #10 RH (5mm)	2-3/8" (60mm)	1000 lbs.** (450kg)	---	4.2 oz. (119g)
505-11	504-11	506-11	Flat Base/Sngl/Delrin™	2" (51mm)	7/16" (11mm)	3-5/8" (92mm)	2-7/32" (57mm)	7/8" (22mm)	(4) #10 RH (5mm)	3" (76mm)	1750 lbs.* (795kg)	6.9 oz. (196g)	5.9 oz. (167g)
505-10	504-10	---	Flat Base/Sngl/Alum.	2" (51mm)	7/16" (11mm)	3-5/8" (92mm)	2-7/32" (57mm)	7/8" (22mm)	(4) #10 RH (5mm)	3" (76mm)	1750 lbs. (795kg)	7.5 oz. (213g)	6.5 oz. (184g)
505-28	504-28	---	Flat Base/Dbl/Delrin™	2" (51mm)	7/16" (11mm)	3-5/8" (92mm)	2-7/32" (57mm)	1-19/32" (40mm)	(4) #10 RH (5mm)	3" (76mm)	1750 lbs.** (795kg)	10.7 oz. (303g)	7.9 oz. (224g)
705-11	704-11	706-11	Flat Base/Sngl/Delrin™	2-3/8" (60mm)	1/2" (13mm)	4-3/8" (111mm)	2-3/4" (70mm)	1" (25mm)	(4) 1/4" RH (6mm)	3-5/8" (92mm)	2250 lbs.* (1020kg)	11 oz. (312g)	9.6 oz. (272g)
705-10	704-10	---	Flat Base/Sngl/Alum.	2-3/8" (60mm)	1/2" (13mm)	4-3/8" (111mm)	2-3/4" (70mm)	1" (25mm)	(4) 1/4" RH (6mm)	3-5/8" (92mm)	2250 lbs. (1020kg)	12.4 oz. (351g)	11.0 oz. (312g)
705-28	704-28	---	Flat Base/Dbl/Delrin™	2-3/8" (60mm)	1/2" (13mm)	4-3/8" (111mm)	2-3/4" (70mm)	1-29/32" (48mm)	(4) 1/4" RH (6mm)	3-5/8" (92mm)	2250 lbs.** (1020kg)	15.8 oz. (447g)	13 oz. (368g)

\* SWL for 506-11, 1500 lbs. (680kg), 706-11, 1700 lbs. (771kg) \*\* SWL for Top Sheave of double version 303-29, 200 lbs. (91kg), 504-28/505-28, 350 lbs. (159kg), and 704-28/705-28, 500 lbs. (227kg)

## Curved Base Cheek Blocks

Unique curved base plate fits up to 2" (51mm) dia. spar section for easy mounting. Excellent for control line leads on dinghys and small daysailors.



03-30



200-30

Item Stain.	Item Alum.	Item Ball Brg.	Descrip.	Sheave Dia.	Max Line	L	W	H	Fasteners	C/C	SWL	Weight Stain.	Weight Alum.
30-04	---	200-30*	Curved/Base Sngl/Delrin™	1-1/16" (27mm)	5/16" (8mm)	3-1/2" (89mm)	1" (25mm)	21/32" (17mm)	(4) #10 RH (5mm)	3" (76mm)	900 lbs.* (410kg)	1.5 oz. (42g)	---
03-30	303-30	300-30	Curved/Base Sngl/Delrin™	1-7/16" (37mm)	7/16" (11mm)	3-11/16" (949mm)	1" (25mm)	3/4" (19mm)	(4) #10 RH (5mm)	3-3/16" (94mm)	1000 lbs.* (450kg)	2.2 oz. (62g)	2.1 oz. (2.1 oz.)

\*SWL for 200-30 is 500 lbs (225kg)

## Cheek Block Pad

Choose pad to work with 5 or 7 Series

Item	Descrip.	Mounts to / Works With	Weight
55-60	5 Series Cheek Pad	Fits 2-1/2" to 6" dia. spar section. (64mm-152mm)	1.5 oz. (43g)
55-61	7 Series Cheek Pad	Fits 3" to 7" dia. spar section. (76mm-178mm)	2 oz. (57g)

# Over The Top Blocks

Polished and Tumbled Stainless Steel Cage and Delrin™ Ball Bearings provide an ingenious solution for difficult leads.



706-40

## Over-the-Top Blocks

Designed to bring control lines over the forward edge of cabin houses, coamings or rails. Perfect for Raised Salon designs. Low Friction ball bearing sheaves lead lines easily.



300-40

300-41

300-42



506-40

506-41

506-42

Item	Descrip. Sheave	Sheave Dia	Max Line	L	W	H	Bearing Height	Fasteners	C/C	SWL	Weight
300-40	Over The Top Single / BB	1-7/16" (37mm)	7/16" (11mm)	2-11/32" (60mm)	2" (51mm)	2-11/32" (60mm)	1-13/32" (36mm)	(6)#10 RH (5mm)	1-25/32" (45mm)	650 lbs. (295kg)	4.7 oz. (133g)
300-41	Over The Top Double / BB	1-7/16" (37mm)	7/16" (11mm)	2-11/32" (60mm)	2-11/16" (68mm)	2-11/32" (60mm)	1-13/32" (36mm)	(6)#10 RH (5mm)	1-25/32" (45mm)	650 lbs. (295kg)	7.2 oz. (204g)
300-42	Over The Top Triple / BB	1-7/16" (37mm)	7/16" (11mm)	2-11/32" (60mm)	3-3/8" (86mm)	2-11/32" (60mm)	1-13/32" (36mm)	(6)#10 RH (5mm)	1-25/32" (45mm)	650 lbs. (295kg)	10.0 oz. (328g)
506-40	Over The Top Single / BB	2" (51mm)	7/16" (11mm)	2-7/8" (73mm)	2-1/16" (52mm)	2-15/16" (74mm)	2" (51mm)	(6)#10 RH (5mm)	2-5/16" (59mm)	1000 lbs. (450kg)	8.4 oz. (283g)
506-41	Over The Top Double / BB	2" (51mm)	7/16" (11mm)	2-7/8" (73mm)	2-3/4" (76mm)	2-15/16" (74mm)	2" (51mm)	(6)#10 RH (5mm)	2-5/16" (59mm)	1000 lbs. (450kg)	12.6 oz. (357g)
506-42	Over The Top Triple / BB	2" (51mm)	7/16" (11mm)	2-7/8" (73mm)	3-17/32" (90mm)	2-15/16" (74mm)	2" (51mm)	(6)#10 RH (5mm)	2-5/16" (59mm)	1000 lbs. (450kg)	1 lb. 1 oz. (482g)
706-40	Over The Top Single / BB	2-3/8" (60mm)	1/2" (13mm)	3-3/8" (86mm)	2-1/4" (57mm)	3-7/16" (87mm)	2-5/16" (58mm)	(6)#10 RH (5mm)	2-13/16" (72mm)	1200 lbs. (545kg)	11.6 oz. (329g)
706-41	Over The Top Double / BB	2-3/8" (60mm)	1/2" (13mm)	3-3/8" (86mm)	3-5/32" (80mm)	3-7/16" (87mm)	2-5/16" (58mm)	(6)#10 RH (5mm)	2-13/16" (72mm)	1200 lbs. (545kg)	1 lb. 2 oz. (510g)
706-42	Over The Top Triple / BB	2-3/8" (60mm)	1/2" (13mm)	3-3/8" (86mm)	4-1/16" (104mm)	3-7/16" (87mm)	2-5/16" (58mm)	(6)#10 RH (5mm)	2-13/16" (72mm)	1200 lbs. (545kg)	1 lb. 8.4 oz. (692g)

# Exit Plates - Exit Boxes / Fairlead Blocks

## Exit Plates

Providing a smooth entry and exit for your halyards or control lines is easy with our Stainless Steel exit plates carefully sculpted to eliminate line chafe and wear.



34-49

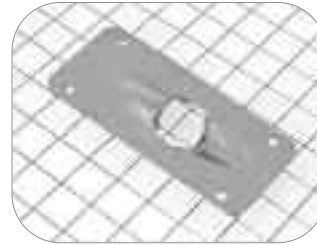

34-48



Item	Descrip.	Halyard Size	Mast Slot Opening	Overall H x W	Center to Center	Fasteners	Weight
34-46	Exit Plate/ Flat	1/2" (12mm)	2-1/4"x13/16" (57mm x 21mm)	3-1/4" x 1-1/4" (82mm x 32mm)	2-3/4" x 3/4" (70mm x 19mm)	(4) #10 RH (5mm)	1 oz. (28g)
34-48	Exit Plate/ Flat	3/4" (19mm)	3-1/4"x1" (83mm x 25mm)	4-5/8" x 2" (118mm x 51mm)	3-5/8" x 1-1/2" (92mm x 38mm)	(4) #10 RH (5mm)	1 oz. (28g)
34-49	Exit Plate/ Curved	3/4" (19mm)	3-1/4"x1" (83mm x 25mm)	4-5/8" x 2" (118mm x 51mm)	3-5/8" x 1-1/2" (92mm x 38mm)	(4) #10 RH (5mm)	2 oz. (57g)

## Exit Boxes

For leading halyards or control lines internally, Schaefer's exit boxes with Stainless Steel construction, Aluminum sheaves and Stainless Steel spacers handle high static halyard and reefing loads. -The front of the cage is flared to fit curved mast sections with an approximate 3" radius.



34-35



34-36

Item	Descrip.	Sheave Size	Halyard Opening	Mast Slot	Fasteners	SWL	Weight
34-35	Exit Box/ Single	2" (51mm)	1/2" * (12mm)	2-5/8" x 13/16" (67mm x 21mm)	(6) #10 RH (5mm)	2250 lbs. (1020kg)	8.2 oz. (234g)
34-36	Exit Box/ Double	2" (51mm)	1/2" * (12mm)	2-5/8" x 1-11/32" (67mm x 21mm)	(6) #10 RH (5mm)	2250 lbs. (1020kg)	13.5 oz. (383g)
34-32	Exit Box/ Single	2-3/8" (60mm)	5/8" ** (16mm)	3" x 1" (76mm x 25mm)	(6) #10 RH (5mm)	2250 lbs. (1020kg)	14 oz. (397g)

\*Max Wire Size 3/16" (5mm)  
\*\* Max Wire Size 7/32" (6mm)

## Fairleads

Injection molded plastic fairleads allow easy and smooth line leads.

**76-05 Thru-Deck Fairlead,**  
H=1-1/8" (29mm).  
Up to 3/8" (10mm) line.

**76-06 Thru-Deck Fairlead,**  
H=1/2" (13mm).  
Up to 5/16" (8mm) line.

**78-51 Deck Fairlead,**  
For guiding line only.  
(2) #10 (5mm) RH Fasteners



76-05



76-06



78-51

# Mainsail / Boom Vangs



35-20

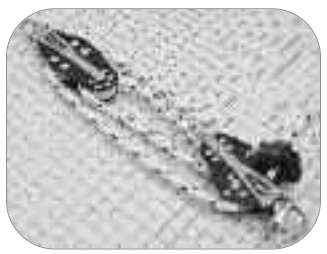

35-04

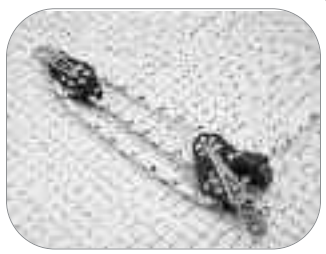

35-01



35-03

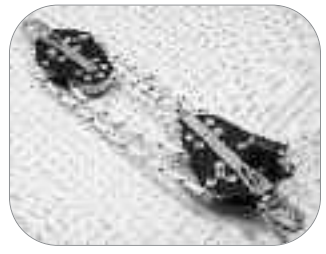

35-13

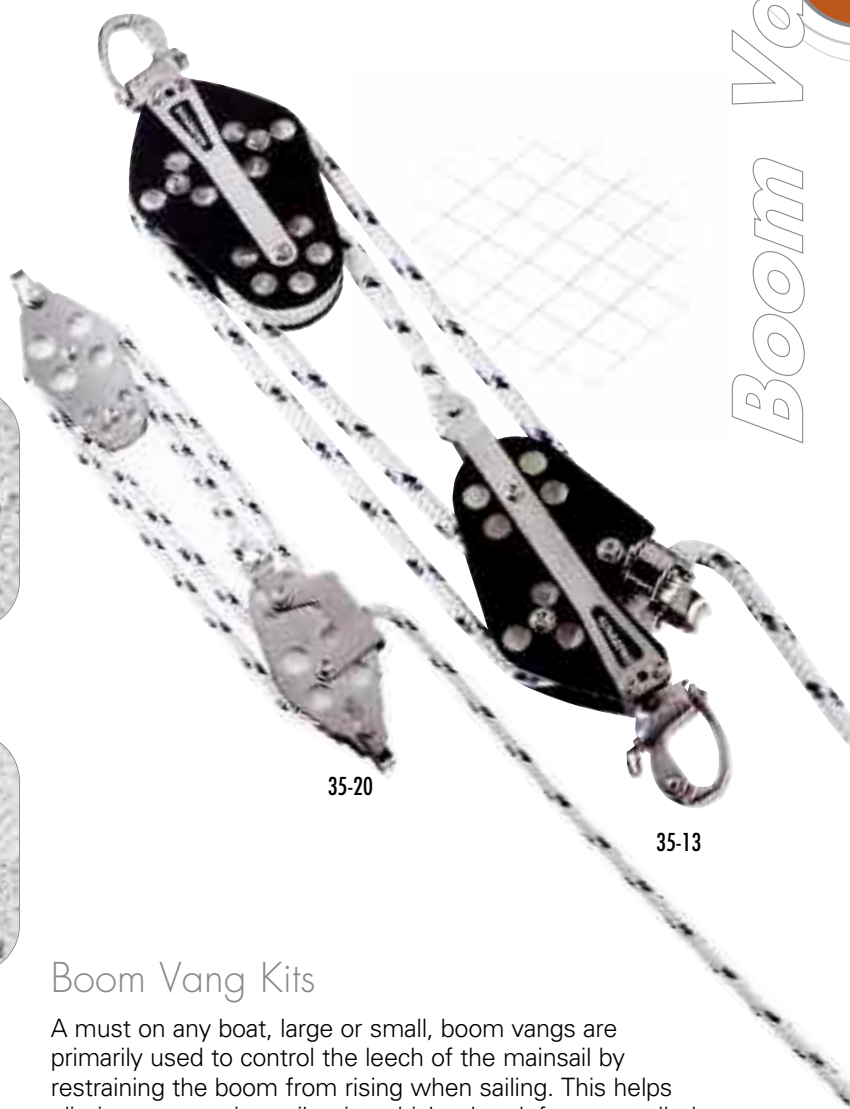

35-20

35-13

## Boom Vang Kits

A must on any boat, large or small, boom vang are primarily used to control the leech of the mainsail by restraining the boom from rising when sailing. This helps eliminate excessive sail twist which when left uncontrolled can make your boat unstable with an increased tendency to roll in waves.

Investment cast snap shackles offer quick and exacting placement of the tackle allowing the system to be moved to the toe rail for use as a preventer. This arrangement "prevents" the boom from swinging back into the boat in light air and also helps avoid accidental gybes in heavy air.

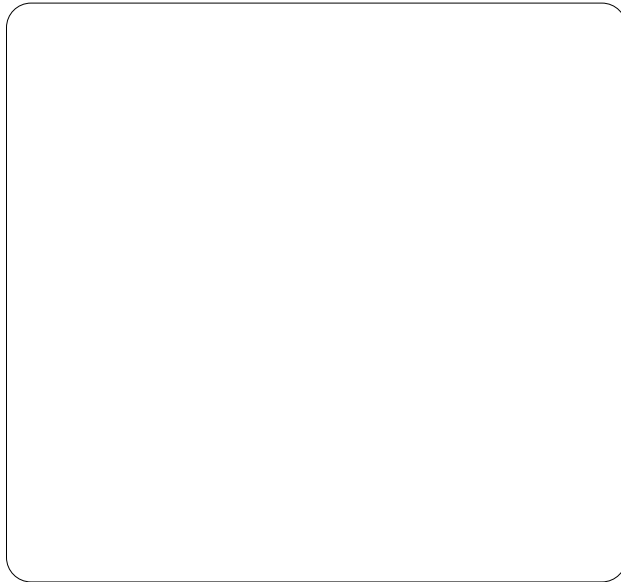

You can easily "double" your purchase to an 8:1 system with the addition of a boom mounted single block and mast dead-end. Call Schaefer for specific recommendations.

Item	Purchase	Boat Size Up To* LOA, Displ., Sail Area	Include Line	SWL	Weight
35-20	4.1	20', 2000 lbs., 225 sq.ft. (6m, 910kg, 21m2)	20'x1/4" (6.1mx6mm)	900 lbs. (410kg)	1 lb. 4 oz. (567g)
35-04	4.1	27', 5000 lbs., 315 sq.ft. (8m, 2270 kg, 29m2)	25'x5/16" (7.6mx8mm)	1000 lbs. (450kg)	2 lbs. (907g)
35-01	3.1	33', 12000 lbs., 520 sq.ft. (10m, 5455kg, 48m2)	30'x3/8" (9.1mx10mm)	1750 lbs. (795kg)	2 lbs. 7 oz. (1.11kg)
35-03	4.1	33', 12000 lbs., 520 sq.ft. (10m, 5455kg, 48m2)	40'x3/8" (12.2mx10mm)	1750 lbs. (795kg)	3 lbs. 1 oz. (1.39kg)
35-13	4.1	38', 18000 lbs., 715 sq.ft. (11.5m, 8182kg, 66m2)	40'x3/8" (12.2mx10mm)	2250 lbs. (1020kg)	4 lbs. 4 oz. (1.93kg)



# Mainsail / Reefing

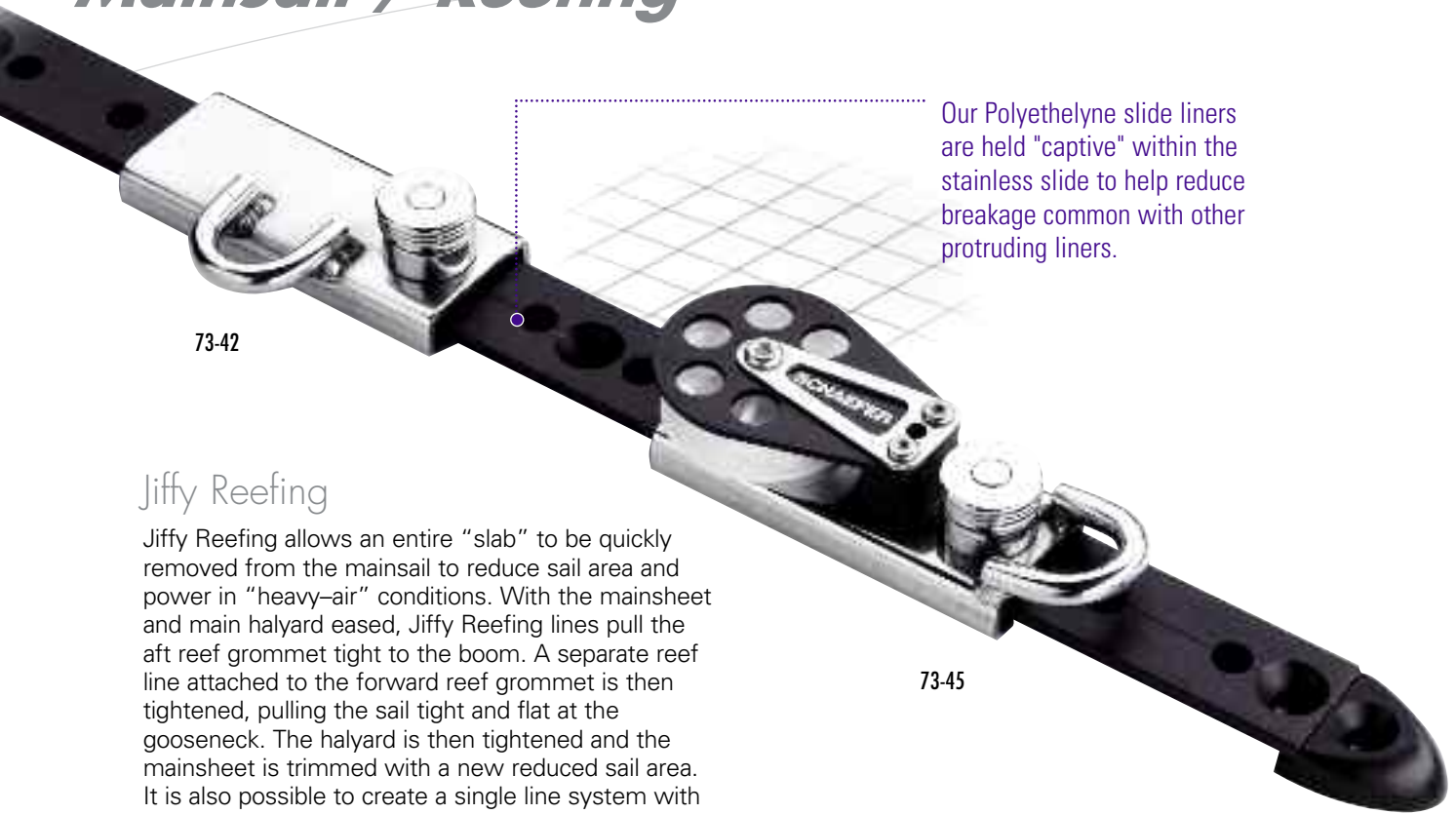

Our Polyethylene slide liners are held "captive" within the stainless slide to help reduce breakage common with other protruding liners.

73-42

73-45

## Jiffy Reefing

Jiffy Reefing allows an entire "slab" to be quickly removed from the mainsail to reduce sail area and power in "heavy-air" conditions. With the mainsheet and main halyard eased, Jiffy Reefing lines pull the aft reef grommet tight to the boom. A separate reef line attached to the forward reef grommet is then tightened, pulling the sail tight and flat at the gooseneck. The halyard is then tightened and the mainsheet is trimmed with a new reduced sail area. It is also possible to create a single line system with Schaefer's unique block selection. Contact Schaefer for more options.



73-42



73-45

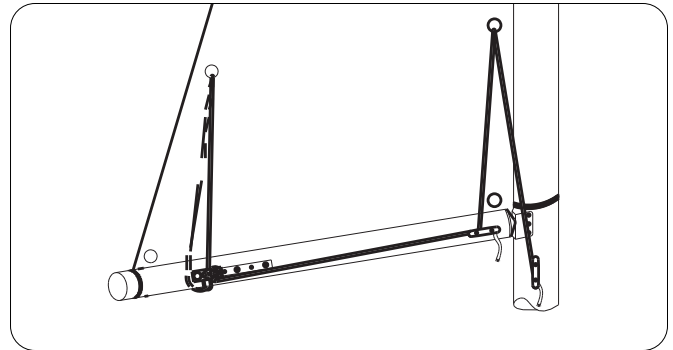

73-36



73-37

Adjustable Jiffy Reefing sliders with welded bails, ride on boom-mounted track to provide proper dead-end attachment point location fore and aft. The reefing line dead ends on the stainless steel bail, leads under the boom and up through the reefing grommet in the sail. The block version leads the line forward along the boom to a spar mounted jam cleat.

Item	Descrip. Sheave	Track Size	Boat Size*	Bail Width	Bail Height	L	W	H	Weight
73-36	Jiffy Reef Slide/Bail/ Lined	1" x 1/8" (25mm x 3mm)	Up to 30' (9.1m)	5/8" (16mm)	7/16" (11mm)	3" (76mm)	1-27/32" (47mm)	15/16" (24mm)	4 oz. (113g)
73-37	Jiffy Reef Block/Bail/ Lined	1" x 1/8" (25mm x 3mm)	Up to 30' (9.1m)	5/8" (16mm)	1-1/16" (27mm)	3" (76mm)	2-7/16" (62mm)	31/32" (25mm)	4 oz. (113g)
73-42	Jiffy Reef Slide/Bail/ Lined	1-1/4" x 3/16" (32mm x 5mm)	Up to 35' (10.7m)	13/16" (21mm)	1-7/32" (13mm)	4" (102mm)	2-11/32" (60mm)	1-3/32" (28mm)	5 oz. (142g)
73-45	Jiffy Reef Block/Bail/ Lined	1-1/4" x 3/16" (32mm x 5mm)	Up to 35' (10.7m)	13/16" (21mm)	1-3/16" (30mm)	3-19/32" (91mm)	3" (76mm)	1-5/32" (30mm)	8 oz. (227g)

# Mainsail / Lazy Jacks

## Lazy Jack Kits

Lazy Jacks are designed to control the mainsail when reefing or dousing. They easily tame today's Full Batten Mainsails and work well with more conventional sails. Schaefer's Lazy Jacks "funnel" the sail down to the boom and retain it, keeping you safe in the cockpit to properly secure the sail when you are moored. Our design allows for the use of an existing sailcover without the need for extensive modifications. The use of thimbled eye straps attached to the bottom of your boom keep the hardware away from the cover and enable you to tuck your sailcover under the lazy jack control lines.

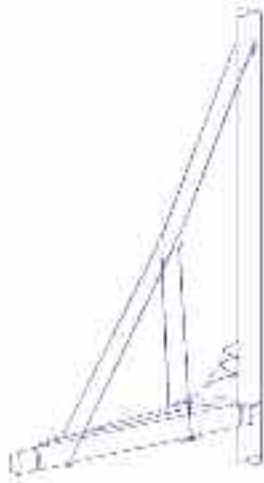

99-62 99-63

### Each kit includes:

Fasteners, eye straps, open base cleats, lashing eye blocks with elkhide, chafe guards, vinyl coated wire and Dacron Yacht braid with eye splices.

Item	Boat Size	Mainsail Luff	Boom Foot	Included Wire (vinyl coated)	Included Line (yacht braid)	Weight
99-62	24'-29' (7.3m-8.8m)	26'-32' (7.9m-9.8m)	8'-10' (2.4m-3m)	11' 6" (3.5m)	60'x1/4" (18.3mx6mm)	2 lbs. 10 oz. (1.20kg)
99-63	30'-36' (9m-11m)	33'-38' (10m-11.6m)	10'-12' (3m-3.7m)	14' (4.3m)	75' x 1/4" (22.9mx6mm)	4 lbs. 12 oz. (2.15kg)
99-64	37'-48' (11.3m-14.6m)	39'-50' (11.8m-15m)	12'-16' (3.7m-4.9m)	16' (4.9m)	92'x5/16" (28mx8mm)	9 lbs. (4.08kg)

99-64



99-62 99-63



99-64



**If you have any questions about your choices, contact Schaefer for assistance.**

# Schaefer Travelers

## The Toughest Car on the Track

While most mainsail working loads are fairly predictable, it is easy to overlook “shock” loads that may be experienced by a traveler system. Jibing, for example can produce shock or impact loads well beyond normal sailing loads, as can the flogging of the boom and mainsail during reefing.

All three sizes of Schaefer Traveler track are extruded from thick walled aluminum. This allows the track to maintain dimensional stability and structural integrity better than thinner designs even when subjected to bending, twisting or compound curves. Each Track section is black hardcoat anodized for maximum corrosion resistance and is treated with a Teflon™ impregnation to extend the life of the coating while reducing friction on the track surface.

Each Traveler Car contains separate “wheels” that hold “captive” stainless steel ball bearings. This captive wheel design with full radius races distributes bearing loads evenly to a greater surface contact area than other plastic bearing designs to ensure smooth running. They also allow you to remove the car for inspection without the loss of bearings. Each one is also hardcoat anodized for durability.

Our Control Blocks use Schaefer's Delrin™ Ball Bearing Sheaves and some use our Fast Entry Cam Cleats for ultimate control. We provide you with several combinations to give you the purchase needed to tame your main!

Choose from our numerous Adapters allowing your Schaefer Blocks to plug in to your Traveler car. Cap off the track with endstops made from UV Treated Urethane to take the shock loads possible from your system.

**SCHAEFER**  
**LEGENDARY STRENGTH**



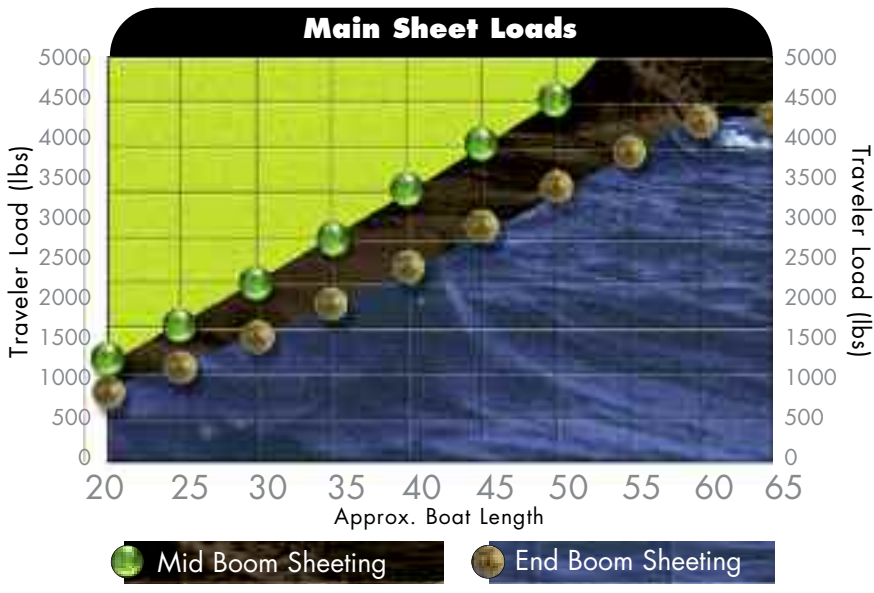

## 1 Determine your Mainsheet Load

Use the Mainsheet Load chart to determine what loads your mainsheet creates. Once establishing this information, proceed to step 2 and select the track and components recommended for your size boat.

## 2 Selecting your Schaefer Traveler Components.

Once determining your Mainsheet loads, you can select your Schaefer traveler setup using the following charts as a guide. Average boats to 30' (9.1m) should use our 1 1/8" track. Most boats from 30'(9.1m) - 50'(15.2m) will use our 1 1/2" systems.

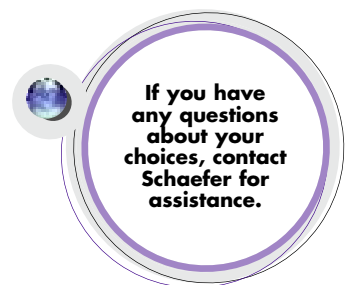

1-1/8" Traveler Systems, most boats to 30' (9.1m)

Page 42-43	Up to 27' (8.2m) End Boom Sheeting	Up to 30' (9.1m) End Boom Sheeting	Up to 27' *(8.2m) Mid-Boom Sheeting
Traveler Track	42-74	42-74	42-74 *
	42-75	42-75	42-75 *
	42-76	42-76	42-76 *
Traveler End Stop	74-90	74-90	74-90
Traveler Cars	72-32	72-39	72-36
	72-36	72-42	72-42
Traveler Control Blocks	74-94	74-94	74-22
	74-22	74-22	74-25
	74-25	74-25	74-23/74-24
	74-23/74-24	74-23/74-24	---
Traveler Adapters	78-45	78-47	78-45
	78-47		78-47

\* Maximum Open Span is 24"

1 1/2" Traveler systems, most boats to 50'(15.2m)  
1 1/2" Bridge Traveler systems, most boats to 45' (13.7m)

Page 44-47	Up to 38' (11.6m) End Boom Sheeting	Up to 50' (15.2m) End Boom Sheeting	Up to 32' *(9.8m) Mid-Boom Sheeting	Up to 45' (13.7m) Mid-Boom Sheeting
Traveler Track	42-84	42-84	42-84 *	42-94 **
	42-85	42-85	42-85 *	42-95 **
	42-86	42-86	42-86 *	42-96 **
	42-88	42-88	42-88 *	---
Traveler End Stop	74-91	74-91	74-91	74-93
Traveler Cars	72-80	72-100	72-80	72-100
	72-83	72-78 72-92	72-83	72-78 72-92
Traveler Control Blocks	74-95	74-95	74-77	74-86/74-87
	74-77	74-77	74-85	74-77
	74-85	74-85	74-83/74-84	74-85
	74-83/74-84	74-83/74-84		74-83/74-84
Traveler Adapters	78-47	78-44	78-47	---
	78-48	78-49	78-48	---

\* Maximum Open Span is 32" If you're span is wider, use our Bridge Style track. \*\* Maximum Open Span is 36".

## 3 Custom Tracks

Schaefer can also custom bend track to suit your needs. If needed, Schaefer will bend your traveler track with either a horizontal, vertical or compound bend for an additional fee. To order a curved track, please provide Schaefer with the chord depth or radius measurement of the bend and what direction the bend is in. Please contact Schaefer with any questions.

# 1-1/8" Traveler System

## Traveler System

Designed for boats up to 30 feet in length, Schaefer's 1-1/8" traveler system uses captive stainless steel ball bearing "wheels" with full radius races to evenly distribute loads. (72-36-PK Traveler Kit pictured)

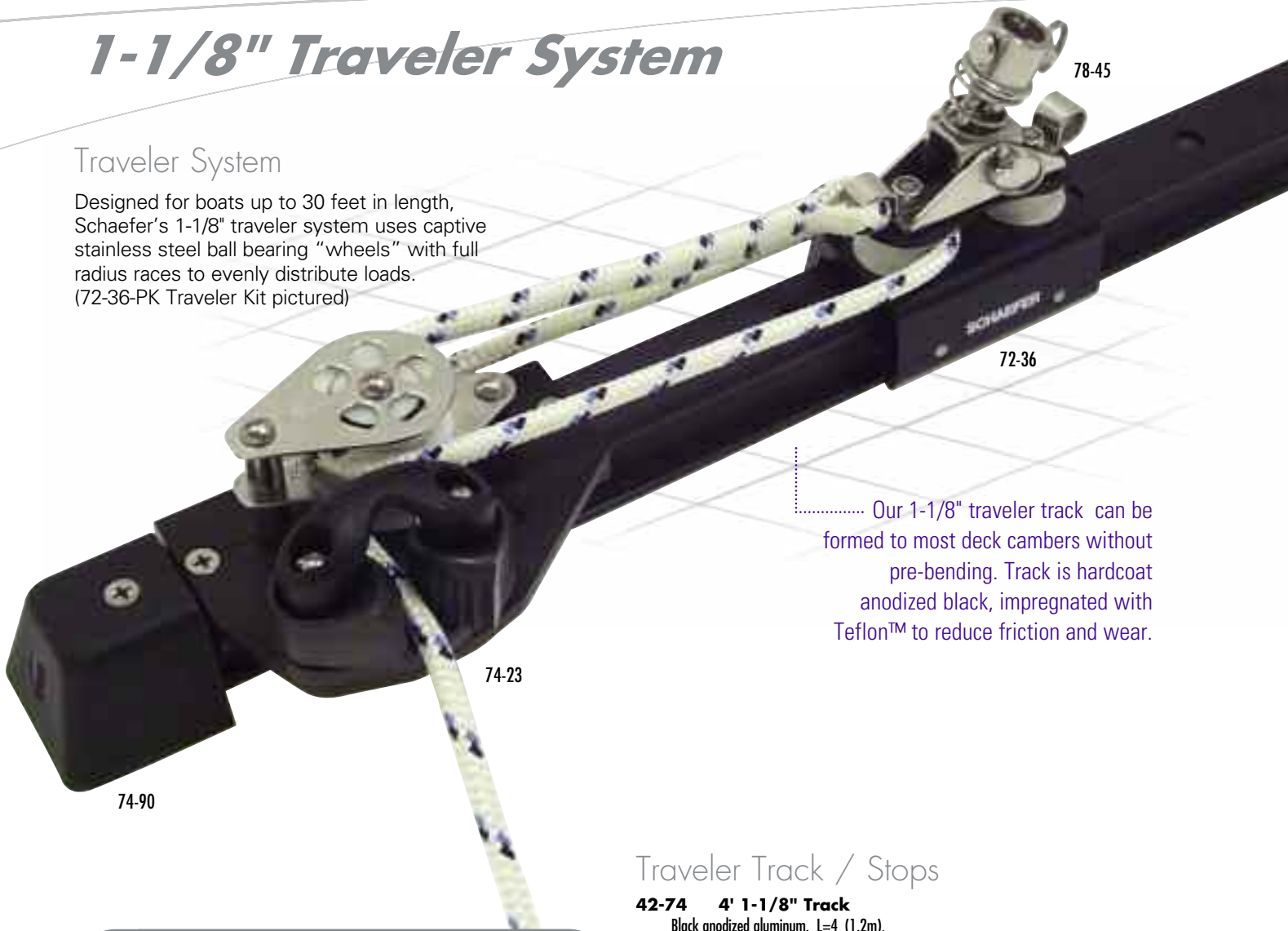

Our 1-1/8" traveler track can be formed to most deck cambers without pre-bending. Track is hardcoat anodized black, impregnated with Teflon™ to reduce friction and wear.

### 1-1/8" Track Specifications

Schaefer's 1-1/8" Traveler Track is hardcoat anodized black with Teflon™ impregnation to reduce friction and wear. Available for boats between 20' and 30'. Uses #10 fasteners on 4" hole centers, countersunk to serve as optional stop pin holes.

**Extruded marine grade thick walled aluminum:** maintains dimensional stability and structural integrity better than thin walled designs even when subjected to bending, twisting or compound curves. Available in 4', 5', and 6' lengths.

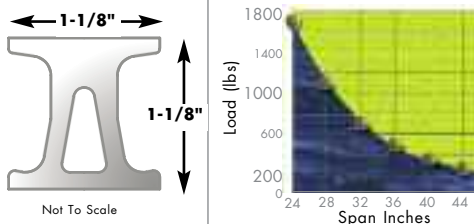

## Traveler Track / Stops

- 42-74 4' 1-1/8" Track**  
Black anodized aluminum. L=4 (1.2m),  
W=1-1/8" (29mm), H=1-1/8" (29mm), Weight=2 lbs. 12 oz.(1.24kg)
- 42-75 5' 1-1/8" Track**  
Black anodized aluminum. L=5 (1.5m),  
W=1-1/8" (29mm), H=1-1/8" (29mm), Weight=3 lbs. 6 oz.(1.54kg)
- 42-76 6' 1-1/8" Track**  
Black anodized aluminum. L=6 (1.8m),  
W=1-1/8" (29mm), H=1-1/8" (29mm), Weight=4 lbs. 1 oz.(1.85kg)
- 74-94 Adjustable Track Stop**  
L=1-7/16" (37mm), W=1 5/8" (42mm), H=1-3/16" (30mm)  
Weight= 2oz. (57g)
- 74-90 Track End**  
L=3/4" (19mm), W=2" (51mm), H=1-7/16" (37mm)  
Weight= 2oz. (57g)



74-94 Adjustable Track Stop



74-90 Track end

# 1-1/8" Traveler System

Four Wheel Track Cars

**Ideal for end boom sheeting boats to 27':**

Use with Schaefer 5 Series Blocks for typical mainsheets see page 16.

**SWL:** 1750 lbs. (740kg.)



72-32 Channel



72-36  
Dual Sheave  
4 Wheel

Use with 78-45 5-Series adapter

Six Wheel Track Cars

**Ideal for end boom sheeting boats to 30' or mid-boom sheeting on boats to 27':**

Use with Schaefer 7 Series Blocks for typical mainsheets see page 20.

**SWL:** 2250 lbs. (1020kg.)



72-39 Channel



72-42  
Dual Sheave  
6 Wheel

Use with 78-47 7-Series adapter

## Traveler Cars

**72-32 Four Wheel Car/Stainless Channel**

L=3" (76mm), W=1-31/32" (50mm), H=2-3/32" (53mm),  
Weight=8 oz. (227g)

**72-36 Four Wheel Car/Dual Sheave**

L=3" (76mm), W=1-31/32" (50mm), H=2-19/32" (66mm),  
Weight=10 oz. (284g)

**72-39 Six Wheel Car/Stainless Channel**

L=4-1/2" (114mm), W=1-31/32" (50mm), H=2-13/32" (61mm),  
Weight=12 oz. (340g)

**72-42 Six Wheel Car/Dual Sheaves**

L=4-1/2" (114mm), W=1-31/32" (50mm), H=3-3/32" (79mm),  
Weight=1 lbs. (454g)

## Accessories

**78-45 5-Series Stand-up Adapter**

L=7/8" (22mm), W=11/16" (17mm),  
H=2-1/32" (51mm),  
Weight=2 oz. (57g)

**78-47 7-Series Stand-up Adapter**

L=1-1/4" (32mm), W=3/4" (19mm),  
H=2-23/32" (69mm),  
Weight=4 oz. (113g)

**78-93 Dead-End Bail**

L=1" (25mm), W=7/16" (11mm),  
H=9/16" (14mm),  
Weight=1 oz. (28g)



78-47 7 Series Adapter

## Control Blocks

**Clean, simple line adjustment:**

Up to 3:1 purchase greatly reduces effort required to pull car to windward.

**74-22 Control Block Single Sheave**

For mainsheet, vang, or small multi-purchases.  
L=4-7/16" (113mm), W=7/8" (12mm), T=15/32" (12mm), Weight=1oz.(28g)

**74-25 Control Block Double Sheave**

Becket provides a solid dead end for multi-purchases.  
L=4-7/16" (113mm), W=7/8" (12mm), T=15/32" (12mm),  
Weight=1oz.(28g)

**74-23 Control Block Double Sheave / Cam**

Adjustable mounting holes allow 3 cam positions.  
L=4-7/16" (113mm), W=7/8" (12mm), T=15/32" (12mm), Weight=1oz.(28g)

**74-24 Control Block Double Sheave / Cam**

Adjustable mounting holes allow 3 cam positions  
L=4-7/16" (113mm), W=7/8" (12mm), T=15/32" (12mm), Weight=1oz.(28g)



74-22 Single Sheave



74-25 Double Sheave



74-23 Double Sheave/Cam



74-24 Double Sheave/Cam

# 1-1/2" Traveler System

## 1-1/2" Traveler System

Schaefer's 1-1/2" Traveler Systems feature stainless steel ball bearings in "captive" wheels that distribute loads to a rolling surface for minimal frictional resistance. Offered in a variety of track lengths, cars, control blocks and adapters; Schaefer offers you the flexibility to match your needs. (72-78-PK Traveler kit shown)



### 1-1/2" Track Specifications

Schaefer's 1-1/2" Traveler Track is hardcoat anodized black with Teflon™ impregnation to reduce friction and wear. Available for boats between 30' – 50'. Uses 1/4" (6mm) fasteners on 2" (51mm) hole centers, countersunk to serve as optional stop pin holes.

**Extruded marine grade thick walled aluminum:** maintains dimensional stability and structural integrity better than thin walled designs even when subjected to bending, twisting or compound curves. Available in 4', 5', 6' and 8' lengths.

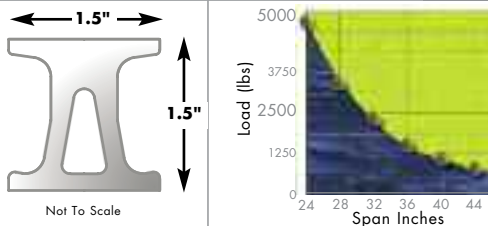

## Traveler Track / Stops

- 42-84 4' 1-1/2" Track**  
Black anodized aluminum. L=4 (1.2m),  
W=1-1/2" (38mm), H=1-1/2" (38mm), Weight= 4 lbs. 12 oz.(2.15kg)
- 42-85 5' 1-1/2" Track**  
Black anodized aluminum. L=5 (1.5m),  
W=1-1/2" (38mm), H=1-1/2" (38mm), Weight= 5 lbs. 15 oz.(2.67kg)
- 42-86 6' 1-1/2" Track**  
Black anodized aluminum. L=6 (1.8m),  
W=1-1/2" (38mm), H=1-1/2" (38mm), Weight= 7 lbs. 2 oz.(3.22kg)
- 42-88 8' 1-1/2" Track**  
Black anodized aluminum. L=8 (2.1m),  
W=1-1/2" (38mm), H=1-1/2" (38mm), Weight= 8 lbs. 5 oz.(3.75kg)
- 74-95 Adjustable Track Stop**  
L=1 3/4" (44mm) , W=2-3/32" (54mm), H=1-5/8" (42mm)  
Weight= 6oz. (170g)
- 74-91 Track End**  
L=1-7/8" (48mm) , W=2-9/16" (65mm), H=1-13/16" (46mm)  
Weight= 4oz. (113g)



74-95 Adjustable Track Stop



74-91 Track end

# 1-1/2" Traveler System

Four Wheel Track Cars

**Ideal for end boom sheeting boats to 38' or mid-boom for boats to 32:**

Use with Schaefer 7, 8 or M-Series Blocks

**SWL:** 2750 lbs. (1247kg.)



72-80 Stainless Channel



72-83  
Dual Sheave  
4 Wheel

Use with 78-47 7-Series adapter or 78-48 adapter for 8 Series

Six Wheel Track Cars

**Ideal for end boom sheeting boats to 50' or mid-boom for boats to 45'**

Use with Schaefer 8, 10 or M-Series Blocks.

**SWL:** 3750 lbs. (1701kg.)



72-78 Dual Sheave  
6 Wheel



72-92 Stacked Sheave  
6 Wheel



72-100

Use with 78-44 8 Series adapter or 78-49 adapter for 10 Series

## Traveler Cars

**72-80 Four Wheel Car/Stainless Channel**  
L=3-19/32" (91mm), W=2-17/32" (64mm), H=2-27/32" (72mm),  
Weight=1 lb 2 oz. (510g)

**72-83 Four Wheel Car/Dual Sheave**  
L=3-19/32" (91mm), W=2-17/32" (64mm), H=3-13/32" (87mm),  
Weight=1 lb 10 oz. (737g)

**72-78 Six Wheel Car/Dual Sheave**  
L=5-13/32" (137mm), W=2-17/32" (64mm), H=3-21/32" (93mm),  
Weight=2 lbs. (907g)

**72-92 Six Wheel Car/Stacked Sheaves**  
L=5-13/32" (137mm), W=2-17/32" (64mm), H=4-17/32" (115mm),  
Weight=2 lbs. 8 oz. (1.13kg)

**72-100 Eight Wheel Car/10 Series Adapter/In-Line Sheaves**  
L=7-3/4" (197mm), W=2-17/32" (64mm), H=6" (152mm), Weight = 3 lbs. 15oz. (1.79kg)

## Accessories

**78-47 7-Series Stand-up Adapter**  
L=1-1/4" (32mm), W=3/4" (19mm),  
H=2-23/32" (69mm), Weight=4 oz. (113g)

**78-48 8 Series Stand-up Adapter**  
L=1-1/4" (32mm), W=1-5/32" (29mm),  
H=2-9/16" (65mm), Weight=4 oz. (113g)  
use with four wheel cars

**78-44 8 Series Stand-up Adapter**  
L=1-1/4" (32mm), W=1-5/32" (29mm),  
H=2-11/16" (68mm), Weight=4 oz. (113g)  
use with six wheel cars

**78-49 10 Series Stand-up Adapter**  
L=1-1/2" (38mm), W=1-5/32" (29mm), H=3-9/32" (83mm),  
Weight=4 oz. (113g)

**78-92 Dead-End Bail**  
Attaches under lock nut on traveler car 1/2" (13mm) I.D.  
Weight= 1oz. (28g)



78-44 8 Series Adapter

## Control Blocks

**74-77 Control Block Single Sheave**  
Removable becket for pre-spliced line.  
L=5-1/4" (133mm), W=2-1/16" (52mm), T=1-15/32" (38mm), Weight=14oz.(379g)

**74-85 Control Block Double Sheave**  
Use for remote cleat or winch leads.  
L=5-1/4" (133mm), W=2-1/16" (52mm), T=2-7/32" (56mm), Weight=1 lbs. 1oz.(482g)

**74-83 Control Block Double Sheave / Cam / Port**  
Use with 72-83, 72-78 for 3:1. Use with 72-92 for 4:1.  
L=5-1/4" (133mm), W=3-5/8" (92mm), T=2-7/32" (56mm), Weight=11lbs.4oz.(567g)

**74-84 Control Block Double Sheave / Cam / Starboard**  
Use with 72-83, 72-78 for 3:1. Use with 72-92 for 4:1.  
L=5-1/4" (133mm), W=3-5/8" (92mm), T=2-7/32" (56mm), Weight=11lbs.4oz.(567g)



74-77 Single Sheave



74-85 Double Sheave



74-83 Double Sheave/Cam



74-84 Double Sheave/Cam



# 1-1/2" Bridge Traveler System

## 1-1/2" Traveler System

Our complete Bridge Traveler System takes the hassle out of converting your boat to a mid-boom system. This high-strength system includes everything you need for a quick installation on boats from 30' (9.1m) to 45' (13.7m).

## Complete Kit 42-00 Includes:

- 42-95** 5 Bridge Track
- 42-36** (2) Hinged Pods
- 506-60** (2) Lift Blocks
- 72-92** Traveler Car
- 74-86** Port Bridge Control Block
- 74-87** Starboard Bridge Control Block
- 74-93** (2) Bridge End Stops

Complete Kit Weight= 26 lbs. 10 oz. (12.1kg)

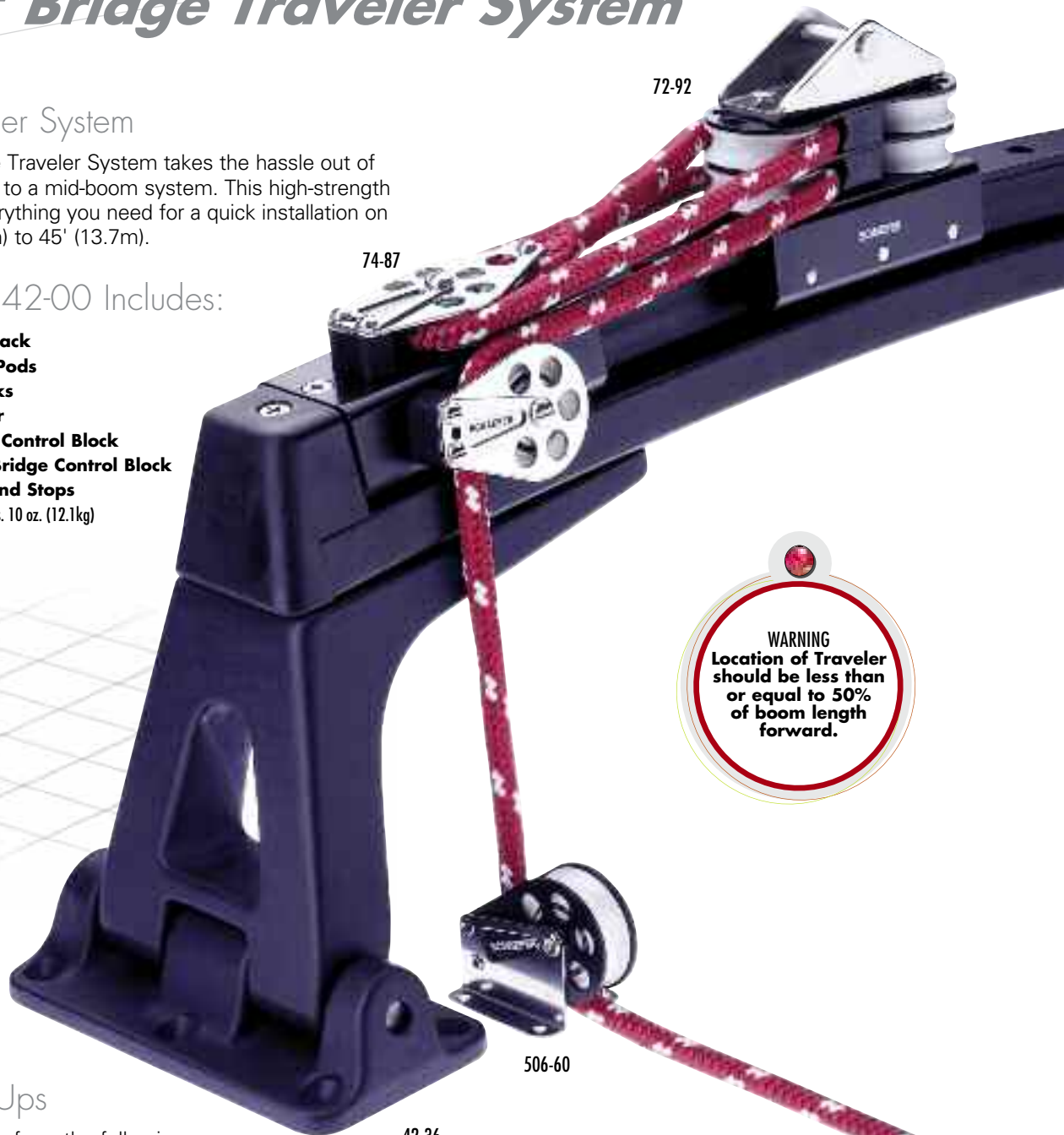

**WARNING**  
Location of Traveler should be less than or equal to 50% of boom length forward.

## Optional Set-Ups

You may also choose from the following products to suit custom applications.

- 42-94** 4 1-1/2" Bridge Track  
L=4 (1.2m), W=2-29/32" (74mm), H=2-5/16" (59mm) Weight=10 lbs. 4oz. (4.75kg)
- 42-95** 5 1-1/2" Bridge Track  
L=5 (1.5m), W=2-29/32" (74mm), H=2-5/16" (59mm) Weight=13 lbs. 2 oz. (5.95kg)
- 42-96** 6 1-1/2" Bridge Track  
L=6 (1.8m), W=2-29/32" (74mm), H=2-5/16" (59mm) Weight=15lbs. 11 oz. (7.13kg)
- 74-93** Bridge Track End  
L=1-7/8" (48mm), W=2-9/16" (65mm), H=2-5/8" (67mm), Weight=4 oz. (113g)
- 42-36** Hinged Pod  
L=7-1/2" (191mm), W=4" (102mm), H=7" (178mm), Weight= 6 lbs. 8 oz. (2.9kg)



74-93



42-36

# 1-1/2" Bridge Traveler System

## Four Wheel Track Cars

**Ideal for mid-boom sheeting boats to 32':**  
 Use with Schaefer 7, 8 or —M-Series Blocks  
 Use with 78-47 7 Series adapter or 78-48 adapter for 8 Series.

**SWL:** 2750 lbs. (1247kg.)



72-80 Channel



72-83 Dual Sheave

Use with 78-47 7-Series adapter or 78-48 adapter for 8 Series

## Six Wheel Track Cars

**Ideal for mid-boom sheeting for boats to 45'**  
 Use with Schaefer 8, 10 or M-Series Blocks

**SWL:** 3750 lbs. (1701kg.)



72-78 Dual Sheave



72-92 Stacked Sheave



72-100

Use with 78-44 8 Series adapter or 78-49 adapter for 10 Series

## Standard Bridge Control Blocks

**74-86 Double Sheave Bridge Control Port**  
 L=5-1/4" (133mm), W=3-3/16" (81mm), H=2-13/32" (61mm)  
 Weight= 2 lbs. (907g)

**74-87 Double Sheave Bridge Control Starboard**  
 L=5-1/4" (133mm), W=3-3/16" (81mm), H=2-13/32" (61mm)  
 Weight= 2 lbs. (907g)



74-86



74-87

## Control Block Options

You may also choose from 1-1/2" control blocks found on page 45 to suit custom applications.

**If you have any questions about your choices, contact Schaefer for assistance.**

## 1-1/2" Track Specifications

Schaefer's 1-1/2" Bridge Traveler Track is hardcoat anodized black with Teflon™ impregnation to reduce friction and wear. Available for boats between 27'– 45'. Stop pin holes drilled on 2" (51mm) centers. Last 3 holes at each end are drilled for 1/4" (6mm) mounting fasteners.

**Extruded marine grade thick walled aluminum:** maintains dimensional stability and structural integrity better than thin walled designs even when subjected to bending, twisting or compound curves. Available in 4', 5' and 6' lengths.

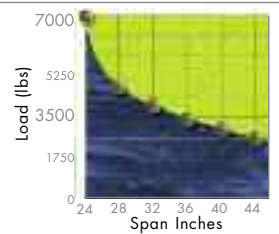
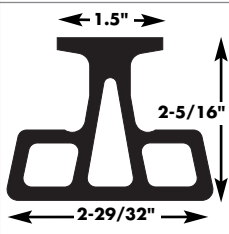

# Snatch Blocks

## Snatch Blocks

Snatch blocks are one of the most versatile tools available for cruising or racing. The flexibility of these blocks makes them ideal for use as genoa leads, spinnaker controls or short sheet leads.

Schaefer's Snatch Blocks use an investment cast snap shackle attached with a Ball joint enabling 360° rotation as well as 15° tilting action. This flexibility allows for quick attachment. Urethane cheek covers protect your deck from damage. Each block has an integral bail allowing you to "hang" the block with a shockcord. Strength, Flexibility and Schaefer's reputation allow you to sail easier and safer.

\*Not appropriate for use as spinnaker guy. Please use 11-99.



Schaefer's extra wide sheave design easily accepts oversized lines. 07-99 and 11-99 turn on our Nomex™/Teflon™ self-lubricating bearing. This high load bearing design consists of Nomex™, DuPont Teflon™ and epoxy-coated glass fibers. In use, Teflon™ migrates from the bearing providing friction reduction with each rotation.



05-99



07-99



11-99

**WARNING:**  
Make sure Block Cage and Snap Shackle are in the fully latched position prior to loading. Failure to close the block will result in damage to the block and potential injury. Schaefer Marine products are designed for marine applications only.

Item	Cheek/Sheave	Sheave Dia.	Max Line	Boat Size Up To* LOA, Displ., Sail Area	L	W	T	SWL	Weight
05-99	Urethane/ Delrin™	1-7/8" (48mm)	5/8" (16mm)	27', 5000 lbs., 315 sq. ft. (8m, 2270kg, 29m <sup>2</sup> )	5-3/8" (136mm)	2-3/8" (60mm)	1-11/16" (43mm)	2250 lbs. (1020kg)	13 oz. (369g)
07-99	Urethane/ Alum.	2-3/8" (60mm)	3/4" (19mm)	38', 18000 lbs., 715 sq. ft.* (11.5m, 8182kg, 66m <sup>2</sup> )	6-11/32" (161mm)	2-11/16" (68mm)	1-13/16" (46mm)	3750 lbs. (1700kg)	1 lb. 5 oz. (595g)
11-99	Urethane/ Alum.	3" (76mm)	3/4" (19mm)	45', 30000 lbs., 900 sq. ft. (13.6m, 13636kg, 83.6m <sup>2</sup> )	7-15/16" (202mm)	3-5/8" (92mm)	2-3/32" (53mm)	5000 lbs. (2270kg)	2 lbs. 7 oz. (1.11kg)

Not appropriate for use as spinnaker guy. Please use 11-99



Make sure that you allow for full articulation of deck or rail mounted snatch blocks. Direct attachment to some toerails limits shackle movement that may lead to potential block failure.

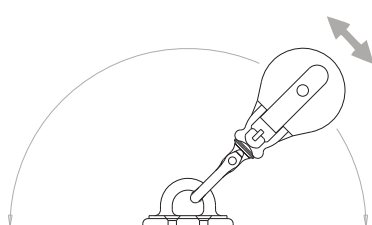

Deck Pad Eye  
Correct Mounting

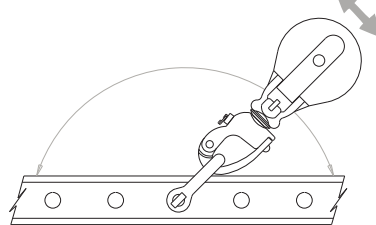

Shackle On Toe Rail  
Correct Mounting

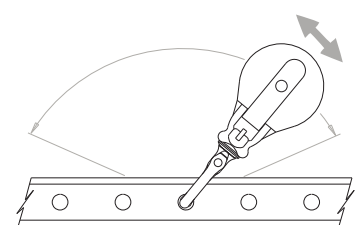

Directly Onto Toe Rail  
Incorrect Mounting

# Foot Blocks

## Foot Blocks

With some of the highest loads on any boat, Foot Blocks must be engineered to withstand some of the highest loads on any boat. With that, Schaefer offers two unique designs. Our M-Series utilizes Computer machined aluminum in conjunction with Torlon™ Rollers and Delrin™ Ball Bearings. The more traditional series of Foot blocks is offered with either an Aluminum or Stainless Steel Top plate for an elegant, yet incredibly strong design. This design uses a computer machined aluminum base as well as an aluminum sheave with ball bearings and our Nomex™/Teflon™ self-lubricating bearing.



M-Series Foot Block



37-15



37-45



37-53



37-55

Item Stain.	Item Alum.	Descrip.	Boat Size Up To* LOA,Disp,Sail Area	Sheave Dia.	Max Line	L	W	H	Fasteners	SWL	Weight Stain.	Weight Alum.
37-15		Single	33', 12000lbs., 520sq.ft. (10m, 5455kg, 48m2)	2-3/8" (60mm)	1/2" (13mm)	4-5/8" (118mm)	2-15/32" (63mm)	1-1/4" (32mm)	(4) 1/4" FH (6mm)	2,500 lbs. (1136kg)	14 oz. (397g)	10 oz. (284g)
37-45		Single	38', 18000lbs, 715sq.ft. (11.5m, 8182kg, 66m2)	3-1/4" (83mm)	5/8" (16mm)	6-23/32" (171mm)	3-3/8" (86mm)	1-5/16" (34mm)	(4) 5/16" FH (8mm)	4,400 lbs (2000kg)	2 lbs, 6 oz. (1.07kg)	1 lb, 11 oz. (765g)
37-46		Double	38', 18000lbs, 715sq.ft. (11.5m, 8182kg, 66m2)	3-1/4" (83mm)	5/8" (16mm)	6-23/32" (171mm)	3-3/8" (86mm)	2-13/32" (61mm)	(4) 5/16" FH (8mm)	2,900 lbs** (1318kg)	3 lbs, 11 oz. (1.66kg)	3 lbs, 1 oz. (1.38kg)
37-55	37-53	Single	45', 30000lbs, 900sq.ft. (13.6m, 13636kg, 83.6m2)	4" (102mm)	3/4" (19mm)	8-3/4" (222mm)	4-5/32" (106mm)	1-21/32" (42mm)	(5) 3/8" FH (10mm)	7,500 lbs (3409kg)	4 lbs, 11 oz. (2.12kg)	3 lbs, 6 oz. (1.52kg)
37-56	37-54	Double	45', 30000lbs, 900sq.ft. (13.6m, 13636kg, 83.6m2)	4" (102mm)	3/4" (19mm)	8-3/4" (222mm)	4-5/32" (106mm)	2-31/32" (76mm)	(5) 3/8" FH (10mm)	5,000 lbs** (2273kg)	7 lbs, 4 oz. (3.28kg)	5 lbs, 15 oz. (2.70kg)
	M66-10	Single	35', 13,000 lbs., 575 sq.ft. (10.7m, 5897kg, 53m2)	2-5/8" (66mm)	1/2" (13mm)	3-11/16" (94mm)	2-5/8" (66mm)	1-1/16" (27mm)	(4) 1/4" FH (6mm)	2800 lbs. (1270kg)		7.2oz. (204gm)
	M82-10	Single	40', 20,000lbs., 800 sq.ft. (12.2m, 9071kg, 74m2)	3-7/32" (82mm)	5/8" (16mm)	4-1/2" (126mm)	3-7/32" (82mm)	1-1/4" (32mm)	(4) 5/16" FH (8mm)	5,000lbs. (2270kg)		12.4oz. (352gm)
	M100-10	Single	45', 30,000lbs., 900 sq.ft. (13.6m, 1363kg, 83.6m2)	4" (100mm)	3/4" (19mm)	5-1/2" (140mm)	4" (100mm)	1-1/2" (37mm)	(4) 3/8" FH (10mm)	7,500 lbs. (3410kg)		25.2oz. (717gm)

\*37-13, 37-15 contain non-ball bearing Delrin™ sheaves. \*\*Denotes SWL per sheave.

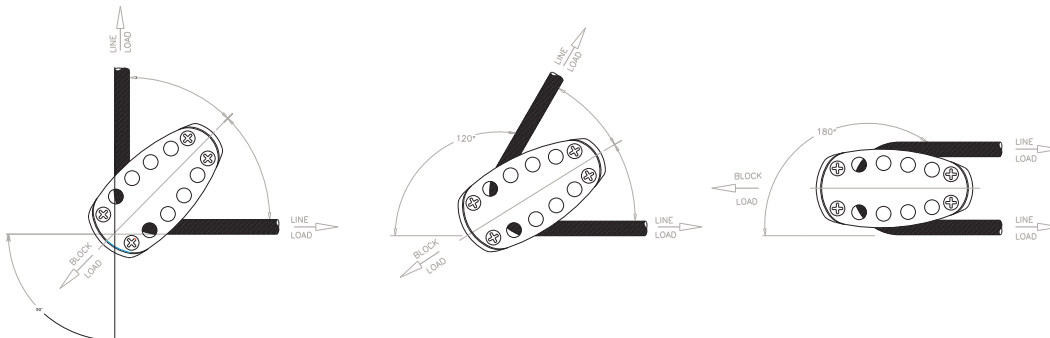

Angle of Deflection	Load Factor
30°	52%
45°	76%
60°	100%
90°	141%
120°	173%
150°	193%
180°	200%

Angle of Deflection Total block loading is dependent not only on line load, but on the angle of deflection between line entry and exit. A 180° turn can produce up to a 200% load increase.

Call 508-995-9511 for Customer Service

**SCHAEFER**  
LEGENDARY STRENGTH

# Genoa Blocks

## Spring Loaded Blocks on Slides

Spring loaded blocks offer a wide flexibility in sheeting angles allowing for up to a 45° lead variation to each side of the track. "Spring Cap" design fully supports blocks under any conditions. 1" and 1-1/4" versions feature polyethylene liners held "captive" within the slide allowing for years of trouble free and friction free service. Choose from brilliant Stainless Steel or Hardcoat Anodized Aluminum cheeks both using UV resistant Delrin™ sheaves. Our New M66-92 features an Aluminum Sheave with Torlon™ Rollers and Delrin™ Ball Bearings for smooth sheeting. Center Hub may be used as a becket to create a 2:1 jib sheet purchase.



03-72



303-72



03-86



303-86



505-82



504-82

Item	Descrip.	Track Size	Boat Size Up To* LOA, Displ., Sail Area	Sheave Dia.	Max Line	L	W	H	Bearing Height	SWL	Weight
03-72	Spr. Loaded S.S.	3/4" x 1/8" (19mm x 3mm)	20', 2000 lbs., 225 sq. ft. (6m, 910kg, 21m2)	1-7/16" (60mm)	7/16" (11mm)	2-1/2" (64mm)	31/32" (25mm)	3-17/32" (90mm)	2-5/32" (55mm)	1000 lbs. (450kg)	4.5 oz. (113g)
303-72	Spr. Loaded Alum.	3/4" x 1/8" (19mm x 3mm)	20', 2000 lbs., 225 sq. ft. (6m, 910kg, 21m2)	1-7/16" (60mm)	7/16" (11mm)	2-1/2" (64mm)	31/32" (25mm)	3-17/32" (90mm)	2-5/32" (55mm)	1000 lbs. (450kg)	4.0 oz. (113g)
03-86	Spr. Loaded/ Lined Slide/S.S.	1" x 1/8" (25mm x 3mm)	27', 5000 lbs., 315 sq. ft. (8m, 2270kg, 29m2)	1-7/16" (60mm)	7/16" (11mm)	3" (76mm)	1-1/4" (31mm)	3-17/32" (90mm)	2-5/32" (55mm)	1000 lbs. (450kg)	4.5 oz. (128g)
303-86	Spr. Loaded/ Lined Slide/Alum.	1" x 1/8" (25mm x 3mm)	27', 5000 lbs., 315 sq. ft. (8m, 2270kg, 29m2)	1-7/16" (60mm)	7/16" (11mm)	3" (76mm)	1-1/4" (31mm)	3-17/32" (90mm)	2-5/32" (55mm)	1000 lbs. (450kg)	4.0 oz. (113g)
505-82	Spr. Loaded/ Lined Slide/S.S.	1" x 1/8" (25mm x 3mm)	27', 5000 lbs., 315 sq. ft. (8m, 2270kg, 29m2)	2" (51mm)	7/16" (11mm)	3" (76mm)	1-1/4" (31mm)	4-5/32" (105mm)	2-7/32" (56mm)	1750 lbs. (795kg)	6.5 oz. (184g)
504-82	Spr. Loaded/ Lined Slide/Alum.	1" x 1/8" (25mm x 3mm)	27', 5000 lbs., 315 sq. ft. (8m, 2270kg, 29m2)	2" (51mm)	7/16" (11mm)	3" (76mm)	1-1/4" (31mm)	4-5/32" (105mm)	2-7/32" (56mm)	1750 lbs. (795kg)	7.0 oz. (198g)
705-92	Spr. Loaded/ Lined Slide/S.S.	1-1/4" x 3/16" (32mm x 5mm)	33', 12000 lbs., 520 sq. ft. (10m, 5455kg, 48m2)	2-3/8" (60mm)	1/2" (12mm)	4" (102mm)	1-9/16" (39mm)	4-15/16" (126mm)	2-5/8" (67mm)	2250 lbs. (1020kg)	14 oz.z. (397g)
704-92	Spr. Loaded/ Lined Slide/Alum.	1-1/4" x 3/16" (32mm x 5mm)	33', 12000 lbs., 520 sq. ft. (10m, 5455kg, 48m2)	2-3/8" (60mm)	1/2" (12mm)	4" (102mm)	1-9/16" (39mm)	4-15/16" (126mm)	2-5/8" (67mm)	2250 lbs. (1020kg)	12 oz. (340g)
08-92	Spr. Loaded/ Lined Slide/S.S.	1-1/4" x 3/16" (32mm x 5mm)	38', 18000 lbs., 715 sq. ft. (11.5m, 8182kg, 66m2)	2-3/8" (60mm)	9/16" (14mm)	4" (102mm)	1-9/16" (39mm)	4-7/8" (124mm)	2-23/32" (69mm)	2750 lbs. (1250kg)	1 lb. (454g)
M66-92	Spr. Loaded/ Lined Slide/Alum.	1-1/4" x 3/16" (32mm x 5mm)	38', 18000 lbs., 715 sq. ft. (11.5m, 8183kg, 66m2)	2-5/8" (66mm)	1/2" (12mm)	4" (102mm)	1-9/16" (39mm)	5-1/2" (140mm)	3" (76mm)	2800 lbs. (1270kg)	1 lb. (454gm)

Replacement liners for 1" = 25-287. Replacement liner for 1-1/4" = 25-286



705-92



704-92



08-92



M66-92

# Genoa Blocks

## Spring Loaded Blocks on Slides

Schaefer's 10-92-uc offers the same flexibility seen in smaller models with the strength needed for offshore designs. Featuring our Universal Circuit "UC" Aluminum Ball Bearing sheave with it's unique Nomex™/Teflon™ bearing, captive lined slider and highly polished Stainless Steel cheeks.



10-92 UC

**If you are in doubt as to the suitability of your selection please contact Schaefer for assistance.**

Item	Descrip.	Track Size	Boat Size Up To* LOA, Displ., Sail Area	Sheave Dia.	Max Line	L	W	H	Bearing Height	SWL	Weight
10-92-UC	Spr Loaded/ Lined Slide/S.S.	1-1/4" x 3/16" (32mm x 5mm)	38', 18000 lbs., 715 sq. ft. (11.5m, 8182kg, 66m2)	3-1/4" (83mm)	5/8" (16mm)	4" (102mm)	1-9/16" (39mm)	6-3/32" (155mm)	3-1/8" (80mm)	3750 lbs. (1700kg)	1 lb. 14 oz. (850g)

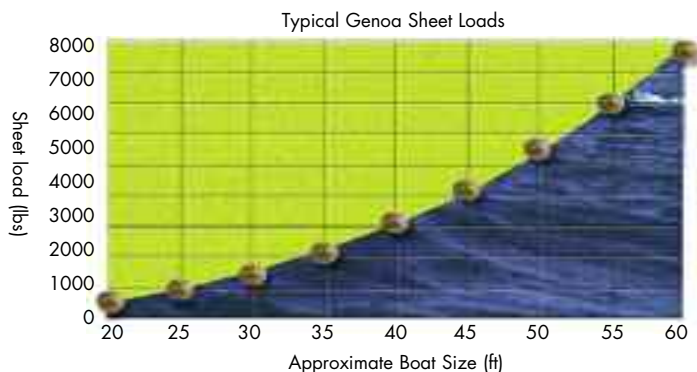

## Half-Moon Lead Blocks

This rugged, "off shore" design provides a low winch lead while spreading sheet loads over several track fasteners for maximum strength. Set pin location in the center of the block to prevent snagging and accidental release.

Designed to articulate up to 45° to either side of the track, Half-Moon lead blocks are often used to provide a proper lead angle to foot or turning blocks near the cockpit. Stainless, bolted construction provides a brilliant finish, and allows complete disassembly for inspection or maintenance.



32-33 UC



32-03 UC

Item	Descrip.	Track Size	Boat Size Up To* LOA, Displ., Sail Area	Sheave Dia.	Max Line	L	W	H	Bearing Height	SWL	Weight
32-03-UC	Half-Moon/ Alum. Shv.	1-1/4"x3/16" (32mmx5mm)	33', 12000 lbs, 520sq.ft. (10m, 5455kg, 48m2)	2-3/8" (60mm)	5/8" (16mm)	4" (102mm)	1-5/8" (41mm)	4-9/32" (109mm)	1-29/32" (49mm)	3000 lbs. (1360kg)	1 lb. 4oz. (567g)
32-33-UC	Half-Moon/ Alum. Shv.	1-1/4"x3/16" (32mmx5mm)	38', 18000 lbs, 715sq.ft. (11.5m, 8182kg, 66m2)	3-1/4" (83mm)	3/4" (19mm)	5-1/2" (140mm)	1-5/8" (41mm)	5-7/32" (140mm)	2-3/32" (54mm)	5000 lbs. (2270kg)	2 lbs. 2oz. (964g)

50-013 is spring for 32-03-UC 50-011 is spring for 32-33-UC

# Genoa Blocks

## Twin Sheet Lead Blocks

Schaefer's Twin Sheet Lead Blocks allow for twin sheets through it's wide flared sheave permitting easy sail changes. The Cage and Slide body are computer machined resulting in incredible strength and precision. Each Block provides a low profile articulating sheave for a proper lead from the sail through the block and into your cockpit. Sheaves are hardcoat anodized aluminum running on our low friction Nomex™/Teflon™ Bearing.

Our 32-81 features a canted design centering the load on the machined aluminum slide. In addition, the aluminum sheave runs on our Nomex™/Teflon™ Bearing as well as Delrin™ Ball Bearings for a very strong and smooth lead. Finally, the addition of two S.S. springs keeps the block upright when not in use.



32-81



32-77



32-88



32-97



32-98

Item	Descrip. Side/Pin	Track Size	Boat Size Up To* LOA, Displ., Sail Area	Sheave Dia.	Max Line	L	W	H	Bearing Height	SWL	Weight
32-88	Twin Sheet Silver	1" x 1/8" (25mmx3mm)	27', 5000 lbs., 315 sq. ft. (8m, 2270kg, 29m2)	1-1/2" (38mm)	(2) 1/2" (13mm)	3-1/2" (89mm)	1-11/32" (34mm)	3-9/32" (83mm)	1-29/32" (49mm)	2500 lbs. (1135kg)	10 oz. (284g)
32-77	Twin Sheet Black	1" x 1/8" (25mmx3mm)	27', 5000 lbs., 315 sq. ft. (8m, 2270kg, 29m2)	1-1/2" (38mm)	(2) 1/2" (13mm)	3-1/2" (89mm)	1-11/32" (34mm)	3-9/32" (83mm)	1-29/32" (49mm)	2500 lbs. (1135kg)	10 oz. (284g)
32-98	Twin Sheet Silver	1-1/4" x 3/16" (32mmx5mm)	38', 18000 lbs., 715 sq. ft. (11.5m, 8182kg, 66m2)	2" (51mm)	(2) 5/8" (16mm)	4-1/2" (114mm)	1-3/4" (44mm)	4-1/2" (114mm)	2-3/4" (70mm)	3500 lbs. (1590kg)	1 lb. 7 oz. (652g)
32-97	Twin Sheet Black	1-1/4" x 3/16" (32mmx5mm)	38', 18000 lbs., 715 sq. ft. (11.5m, 8182kg, 66m2)	2" (51mm)	(2) 5/8" (16mm)	4-1/2" (114mm)	1-3/4" (44mm)	4-1/2" (114mm)	2-3/4" (70mm)	3500 lbs. (1590kg)	1 lb. 7 oz. (652g)
32-81	Twin Sheet Block	1-1/4" x 3/16" (32mm x 5mm)	38', 18000 lbs., 715 sq. ft. (11.5m, 8182kg, 66m2)	2" (51mm)	(2) 5/8" (16mm)	4-1/2" (114mm)	1-3/4" (44mm)	4-1/2" (114mm)	2-3/4" (70mm)	3500 lbs. (1590kg)	1 lb. 7 oz. (652g)



Typical Genoa Sheet Loads

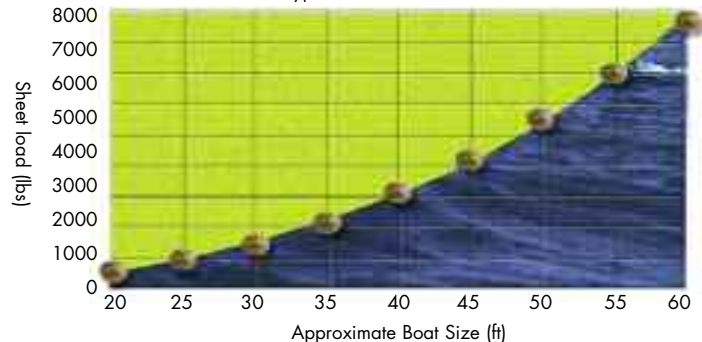

The Nomex™/Teflon™ bearing used in each block is braided and saturated with epoxy resins providing a low-friction surface between the bearing and the stainless steel high load axle. In use, Teflon™ migrates from the bearing providing friction reduction with each rotation.

# Genoa Blocks

## Twin Sheet Lead Blocks

Twin Sheet Lead Blocks feature an extra wide sheave that allows two sheets to be run through the cage at the same time. This is an important feature when you need to change sails, allowing you to avoid sailing without a jib. The new sail can be rigged and hoisted prior to lowering the original jib.

In addition to rigging flexibility, and faster sail changing, another major advantage is the low profile, wide lead angle provided to the winch. Extra wide sheaves plus a 45° tilt in either direction gives greater leeway in sheeting angles allowing winches to be mounted up to 15° to either side of the track. The 32-58 features our low friction Nomex™/Teflon™ Bearing to handle friction with ease.

Our 32-82 featuring an aluminum sheave runs on our Nomex™/Teflon™ Bearing as well as Delrin™ Ball Bearings for a very strong and smooth lead. In addition, we have added two S.S. springs keeps the block upright when not in use. Maintenance is easy with the removable sheave and machined flushing holes. Double your sheeting flexibility with Schaefer.



32-82

Item	Descrip. Side/Pin	Track Size	Boat Size Up To* LOA, Displ., Sail Area	Sheave Dia.	Max Line	L	W	H	Bearing Height	SWL	Weight
32-58	Twin Sheet Silver/Genoa Lead	1-1/4" x 3/16" (31mm x 4.6mm)	44', 28000lbs., 875 sq. ft. (13.4m, 12701kg, 81.3m <sup>2</sup> )	2-11/16" (68mm)	3/4" (19mm)	5-7/8" (149mm)	1-3/4" (44mm)	5-1/8" (130mm)	3" (76mm)	4400 lbs. (2000kg)	2 lbs. 2 oz. (1.0kg)
32-82	Twin Sheet Block	1-1/4" x 3/16" (32mm x 5mm)	44', 28000 lbs., 875 sq. ft. (13.4m, 12701kg, 81.3m <sup>2</sup> )	2-11/16" (68mm)	3/4" (19mm)	5-7/8" (149mm)	1-3/4" (44mm)	5-1/8" (130mm)	3" (76mm)	4400 lbs. (2000kg)	2 lbs. 1 oz.
32-89	Twin Sheet Strain./Screw	1-1/2" x 1/4" (38mm x 6mm)	60', 45000lbs., 900 sq. ft. (18.3m, 20411kg, 83.6m <sup>2</sup> )	3-1/2" (89mm)	(2)7/8" (22mm)	6-3/4" (171mm)	1-15/16" (49mm)	6-7/32" (166mm)	3-13/32" (87mm)	10000 lbs. (4545kg)	5 lbs. 4 oz. (2.83kg)



Our 1-1/2" Twin Sheet Lead Block features a Stainless Steel body and slider for incredible strength and great looks. The 3-1/2" Aluminum sheave runs on our Nomex™/Teflon™ bearing for strength and low friction. The Stainless Steel Screw pin securely locks in the car.

**If you are in doubt as to the suitability of your selection please contact Schaefer for assistance.**



# Genoa Blocks

## Adjustable Twin Sheet Lead Control System for 1" T-Track

Schaefer's unique design offers a simple alternative by utilizing your existing genoa track. Polyethylene liners reduce friction and permit adjustment of your genoa car under load from the safety of your cockpit. Installation involves a minimal amount of hardware mounting on your deck, instead, sliding directly onto your track. Yet another Schaefer innovation you've come to expect.

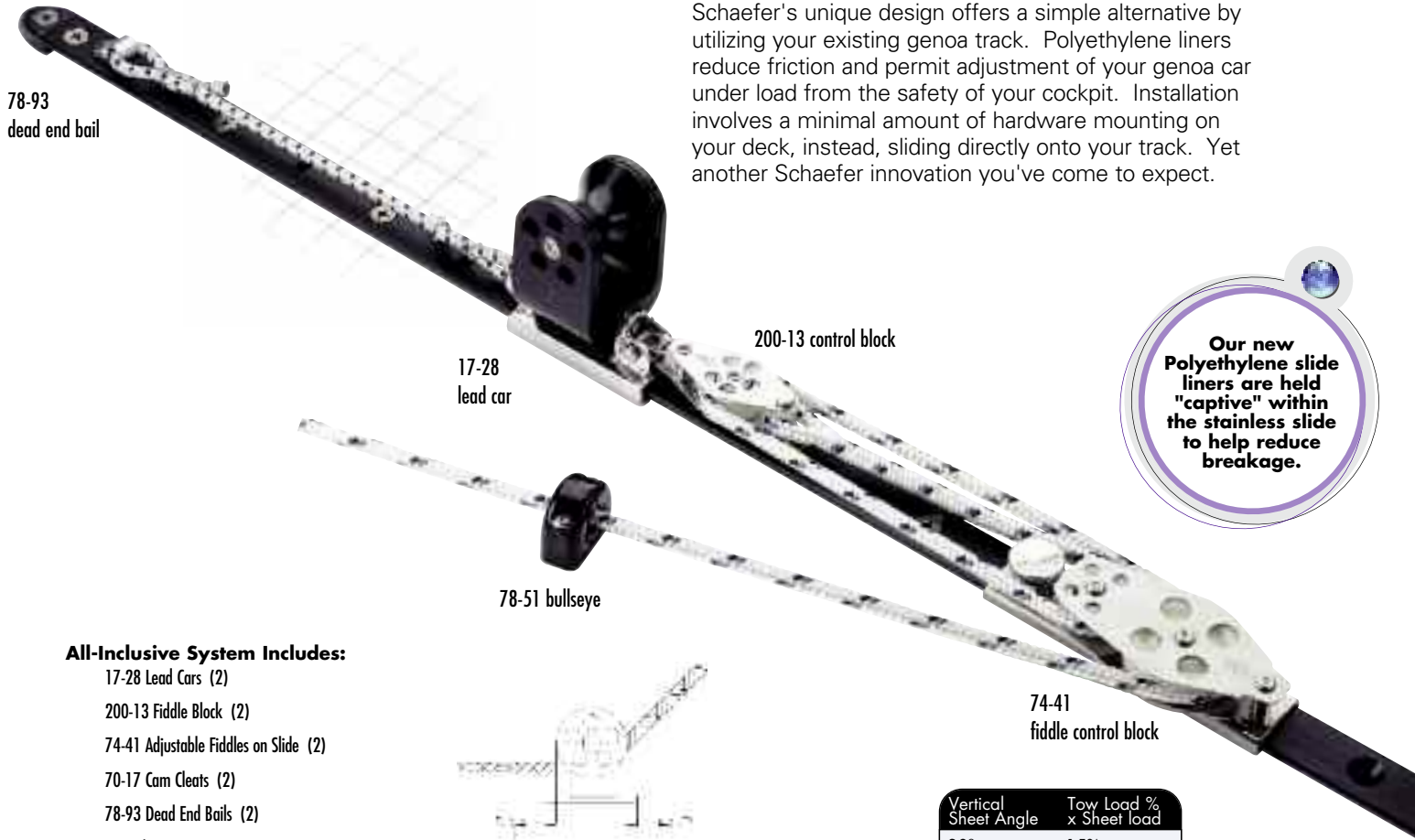

Our new Polyethylene slide liners are held "captive" within the stainless slide to help reduce breakage.

### All-Inclusive System Includes:

- 17-28 Lead Cars (2)
- 200-13 Fiddle Block (2)
- 74-41 Adjustable Fiddles on Slide (2)
- 70-17 Cam Cleats (2)
- 78-93 Dead End Bails (2)
- 40' 1/4" Line (2)
- 10' 1/4" Shock Cord (2)
- 78-51 (2)



Lead car tow loads are dependent on sheet deflection angles. 45° is the most common deflection for #1 genoas making the tow load 30% of the car load. #3 heavy-air sails can deflect up to 70° for a tow load equal to 65% of the lead car load.

Vertical Sheet Angle	Tow Load % x Sheet load
30°	15%
40°	25%
50°	35%
60°	50%
70°	65%

Forward bail accepts a simple 3:1 purchase system for forward movement, while aft sheet pressure holds the block in place. Aft bail is provided for shock cord attachment. Run to a padeye or double up to a cheek block to keep the system in tension when not in use.

Part#	Description	Track Size	Boat Size	Sheave Dia.	Max. Line	L	W	H	Bearing Height	SWL	Weight
17-20	All-Inclusive System	1" x 1-1/8" (25mm x 3.2mm)	33' 12000 lbs. 520 sq.ft.	---	---	---	---	---	---	2500 lbs. (1135kg)	5 lbs. 8 oz. (2.46kg)
17-28	Lead Car Only	1" x 1-1/8" (25mm x 3.2mm)	33' 12000 lbs. 520 sq.ft.	1-1/2" (38mm)	1/2" (13mm)	3" (76mm)	1-1/4" (32mm)	3-9/32" (83mm)	1-29/32" (48mm)	2500 lbs. (1135kg)	10 oz. (0.28kg)
200-13	Fiddle Block	1" x 1-1/8" (25mm x 3.2mm)	33' 12000 lbs. 520 sq.ft.	1-1/16" (27mm)	5/16" (16mm)	4-5/32" (105mm)	1-3/16" (30mm)	19/32" (15mm)	---	500 lbs. (225kg)	1.75 oz. (0.05kg)
74-41	Adjustable Fiddle on Slide	1" x 1-1/8" (25mm x 3.2mm)	33' 12000 lbs. 520 sq.ft.	1-1/16" & 1-3/4" (27mm & 44mm)	5/16" (16mm)	3" (73mm)	1-1/4" (32mm)	3-9/32" (83mm)	1-29/32" (48mm)	500 lbs. (225kg)	15.5 oz. (0.45kg)
70-29	Stainless Steel Cam Cleat	---	---	---	7/16" (11mm)	2-11/16" (68mm)	1-13/32" (36mm)	15/16" (24mm)	---	500 lbs. (225kg)	4.5 oz. (0.12kg)
78-51	Bull's Eye	---	---	---	1/2" (13mm)	1-7/16" (13mm)	11/16" (36mm)	1-5/32" (17mm)	7/16" (29mm)	---	2.5 oz. (0.07kg)
78-93	Dead End Bail	---	---	---	1/2" (13mm)	1-15/32" (37mm)	21/32" (17mm)	11/16" (18mm)	---	---	1 oz. (0.02kg)

# Genoa Blocks

## Adjustable Twin Sheet Lead Control System for 1-1/4" T-Track

Schaefer's Adjustable Lead Control offers a low profile 4:1 purchase system, canted Lead car control system that mounts over your existing Genoa 1-1/4" T-Track. Allows for easy and safe adjustment of Genoa Leads from the safety and comfort of the cockpit.

78-92  
dead end bail

17-68 lead car

506-45 control block

78-51 bullseye

74-44 control block



We've combined our twin sheet lead design with slides using a unique liner made of "slippery" polyethylene. These liners provide a low friction, easy solution to mounting on your existing T-Track. They glide virtually without detectable friction, yet handle up to 3500 lbs. (1590kg) of tension or compression load, without deformation.

Vertical Sheet Angle	Tow Load % x Sheet load
30°	15%
40°	25%
50°	35%
60°	50%
70°	65%

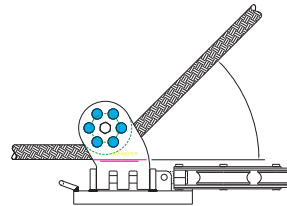

Lead car tow loads are dependent on sheet deflection angles. 45° is the most common deflection for #1 genoas making the tow load 30% of the car load. #3 heavy-air sails can deflect up to 70° for a tow load equal to 65% of the lead car load.

### All-Inclusive System includes:

- 17-68 Lead Cars (2)
- 506-45 Fiddle Block (2)
- 74-44 Adjustable Fiddle on Slide (2)
- 70-27 Cam Cleats (2)
- 78-51 Bull's Eye (2)
- 78-92 Dead End Bails (2)
- 50' 5/16" Line (2)
- 10' 5/16" Shock Cord (2)

Part#	Description	Track Size	Boat Size	Sheave Dia.	Max. Line	L	W	H	Bearing SWL Height	Weight	
17-60	All-Inclusive System	1-1/4" x 3/16" (31mm x 4.6mm)	40' 23000 lbs. 800 sq. ft.	---	---	---	---	---	---	3500 lbs. (1590kg) 11 lbs. 3 oz. (5kg)	
17-68	Lead Car Only	1-1/4" x 3/16" (31mm x 4.6mm)	40' 23000 lbs. 800 sq. ft.	2" (51mm)	5/8" (16mm)	5-1/32" (128mm)	1-9/16" (40mm)	4-3/8" (111mm)	2-9/16" (65mm)	3500 lbs. (1590kg) 1 lb. 10 oz. (0.72kg)	
506-45	Fiddle Block	1-1/4" x 3/16" (31mm x 4.6mm)	40' 23000 lbs. 800 sq. ft.	1-7/16" & 2-1/4" (36mm & 57mm)	1/2" (13mm)	6-7/16" (164mm)	2-3/8" (60mm)	15/16" (24mm)	---	1500 lbs. (675kg) 7.3 oz. (0.22kg)	
74-44	Adjustable Fiddle on Slide	1-1/4" x 3/16" (31mm x 4.6mm)	40' 23000 lbs. 800 sq. ft.	1-7/16" & 2-1/4" (36mm & 57mm)	1/2" (13mm)	5-1/32" (128mm)	1-9/16" (40mm)	4-3/8" (111mm)	2-9/16" (65mm)	1500 lbs. (675kg) 1 lb. 2 oz. (0.5kg)	
70-29	Stainless Steel Cam Cleat	---	---	---	7/16" (11mm)	2-11/16" (68mm)	1-13/32" (36mm)	15/16" (24mm)	---	500 lbs. (225kg) 4.5 oz. (0.12kg)	
78-51	Bull's Eye	---	---	---	1/2" (13mm)	1-7/16" (36mm)	11/16" (17mm)	1-5/32" (29mm)	7/16" (11mm)	---	2.5 oz. (0.07kg)
78-92	Dead End Bail	---	---	---	1/2" (13mm)	1-15/32" (37mm)	21/32" (17mm)	11/16" (18mm)	---	---	1 oz. (0.02kg)

Call 508-995-9511 for Customer Service

**SCHAEFER**  
LEGENDARY STRENGTH

# T-Track

## Aluminum T-Track

Our Aluminum T-Track incorporates a concave shaped riser that allows it to remain steady for spar mounting, or easily accept sealant for mounting to decks. Available in a black hardcoat anodized, or clear anodizing (silver), the color of natural extruded aluminum. All of our T-Track now incorporates additional pin-stop holes at 1-3/8" spacing for more adjustment range.

## End Stops

Track End Stops are made of UV resistant Urethane that helps withstand impact. Available in light gray or black to compliment track.

## Shipping:

Track sections up to 8' (2.4m) are easily shipped by UPS or Fedex. Contact Schaefer Customer service to arrange shipping of longer lengths.

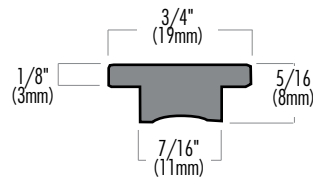

Track Size	Track Type	Items Listed By Length					Fastener* Size	Fastener Spacing	Stop Pin Dia.	Weight Foot	End Stop
		2' (.6m)	4' (1.2m)	6' (1.8m)*	8' (2.4m)	10' (3m)					
3/4" x 1/8" (19mm x 3mm)	Black	40-32	40-34	40-36	40-38	40-40	#10 FH (5mm)	3" (76mm)*	3/16" (5mm)	2.9 oz. (84g)	74-34

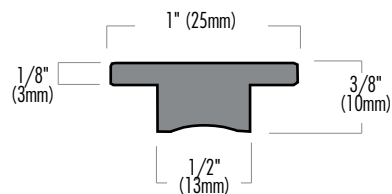

Track Size	Track Type	Items Listed By Length					Fastener* Size	Fastener Spacing	Stop Pin Dia.	Weight Foot	End Stop
		2' (.6m)	4' (1.2m)	6' (1.8m)*	8' (2.4m)	10' (3m)					
1" x 1/8" (25mm x 3mm)	Silver Black	40-62-C 40-62	40-64-C 40-64	40-66-C 40-66	40-68-C 40-68	40-70-C 40-70	40-120-C 40-120	1/4" FH (6mm)	4" (102mm)*	1/4" (6mm)	4.3 oz. (122g) 74-35-6 74-35

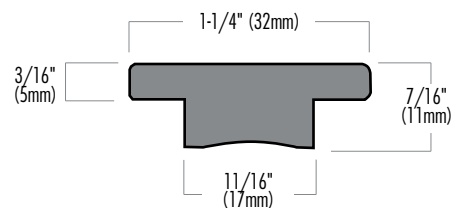

Track Size	Track Type	Items Listed By Length					Fastener* Size	Fastener Spacing	Stop Pin Dia.	Weight Foot	End Stop
		2' (.6m)	4' (1.2m)	6' (1.8m)*	8' (2.4m)	10' (3m)					
1-1/4" x 3/16" (32mm x 5mm)	Silver Black	40-72-C 40-72	40-74-C 40-74	40-76-C 40-76	40-78-C 40-78	40-80-C 40-80	40-82-C 40-82	5/16" FH (8mm)	4" (102mm)*	3/8" (10mm)	6.8 oz. (193g) 74-36-6 74-36

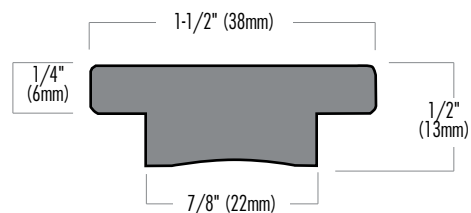

Track Size	Track Type	Items Listed By Length					Fastener* Size	Fastener Spacing	Stop Pin Dia.	Weight Foot	End Stop
		2' (.6m)	4' (1.2m)	6' (1.8m)*	8' (2.4m)	10' (3m)					
1-1/2" x 1/4" (38mm x 6mm)	Black	41-12 Sold ONLY in 12' (3.6m) lengths only					3/8" FH (10mm)	4" (102mm)*	7/16" (11mm)	10.4 oz. (295g)	74-39



# T-Track Accessories

## Stainless T-Track Sliders

Schaefer sliders provide strong, yet easily adjustable attachments for a variety of applications. Lined slides offer a simple answer for metal to metal contact.



72-46



74-46



17-59

Item	Descrip. Pin	Track Size	Boat Size Up To** LOA, Displ., Sail Area	L	W	H	Eye	Eye	SWL***	Weight
72-46*	Eye Slide/ Screw Pin	3/4"x1/8" (19mmx3mm)	20', 2000 lbs. 225 sq. ft. (6m, 910kg, 21m <sup>2</sup> )	3" (76mm)	1" (25mm)	1-3/32" (28mm)	9/16" (14mm)	9/16" (14mm)	750 lbs. (340 kg)	2.5 oz. (71g)
74-46*	Adj. Stop/ Screw Pin	3/4"x1/8" (19mmx3mm)	20', 2000 lbs. 225 sq. ft. (6m, 910kg, 21m <sup>2</sup> )	1" (25mm)	1-3/32" (28mm)	11/32" (9mm)	---	---	---	1 oz. (28g)
17-59	Eye Slide/ Spring/Lined	1"x1/8" (25mmx3mm)	27', 5000 lbs. 315 sq. ft. (8m, 2270kg, 29m <sup>2</sup> )	3" (76mm)	1-3/8" (35mm)	1-3/32" (28mm)	9/16" (14mm)	9/16" (14mm)	750 lbs. (340 kg)	3.2 oz. (91g)
74-48	Adj. Stop/ Screw Pin	1"x1/8" (25mmx3mm)	27', 5000 lbs. 315 sq. ft. (8m, 2270kg, 29m <sup>2</sup> )	1" (25mm)	1-1/4" (31mm)	11/32" (9mm)	---	---	---	1.5 oz. (42g)
72-49	Eye Slide/1 Spring/Lined	1-1/4"x3/16" (32mmx5mm)	33', 12000 lbs. 520 sq. ft. (10m, 5455kg, 48m <sup>2</sup> )	4" (102mm)	1-11/16" (43mm)	1-3/4" (45mm)	1" (25mm)	29/32" (23mm)	2500 lbs. (1134kg)	7.5 oz. (213g)
74-51	Adj. Stop/ Screw Pin	1-1/4"x3/16" (32mmx5mm)	33', 12000 lbs. 520 sq. ft. (10m, 5455kg, 48m <sup>2</sup> )	1-1/2" (38mm)	1-9/16" (39mm)	15/32" (12mm)	---	---	---	2.5 oz. (71g)
73-52	Screw Pin/ Not Lined	1-1/2" x 1/4" (38mmx6mm)	45', 30000 lbs. 900 sq. ft. (13.6m, 1363kg, 83.6m <sup>2</sup> )	6" (152mm)	1-27/32" (47mm)	1-27/32" (47mm)	2-3/16" (56mm)	7/8" (22mm)	5000 lbs. (2270kg)	14 oz. (411g)
74-52	Adj. Stop/ Screw Pin	1-1/2" x 1/4" (38mmx6mm)	45', 30000 lbs. 900 sq. ft. (13.6m, 1363kg, 83.6m <sup>2</sup> )	2" (51mm)	1-27/32" (47mm)	17/32" (13mm)	---	---	---	5.1 oz. (145g)

\* 72-46 and 73-52 do not utilize slide liners. < 25-287 replacement liner for 17-59, 25-286 replacement liner for 72-49 >

\*\* Boat size recommendations are for typical genoa lead applications.



74-48



72-49



74-51

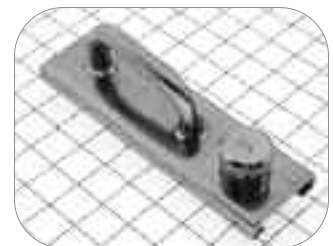

73-52



**WARNING**  
Safe Working  
Loads shown are  
for direct vertical  
pull. Side loads  
will diminish  
these figures.

# Track Accessories

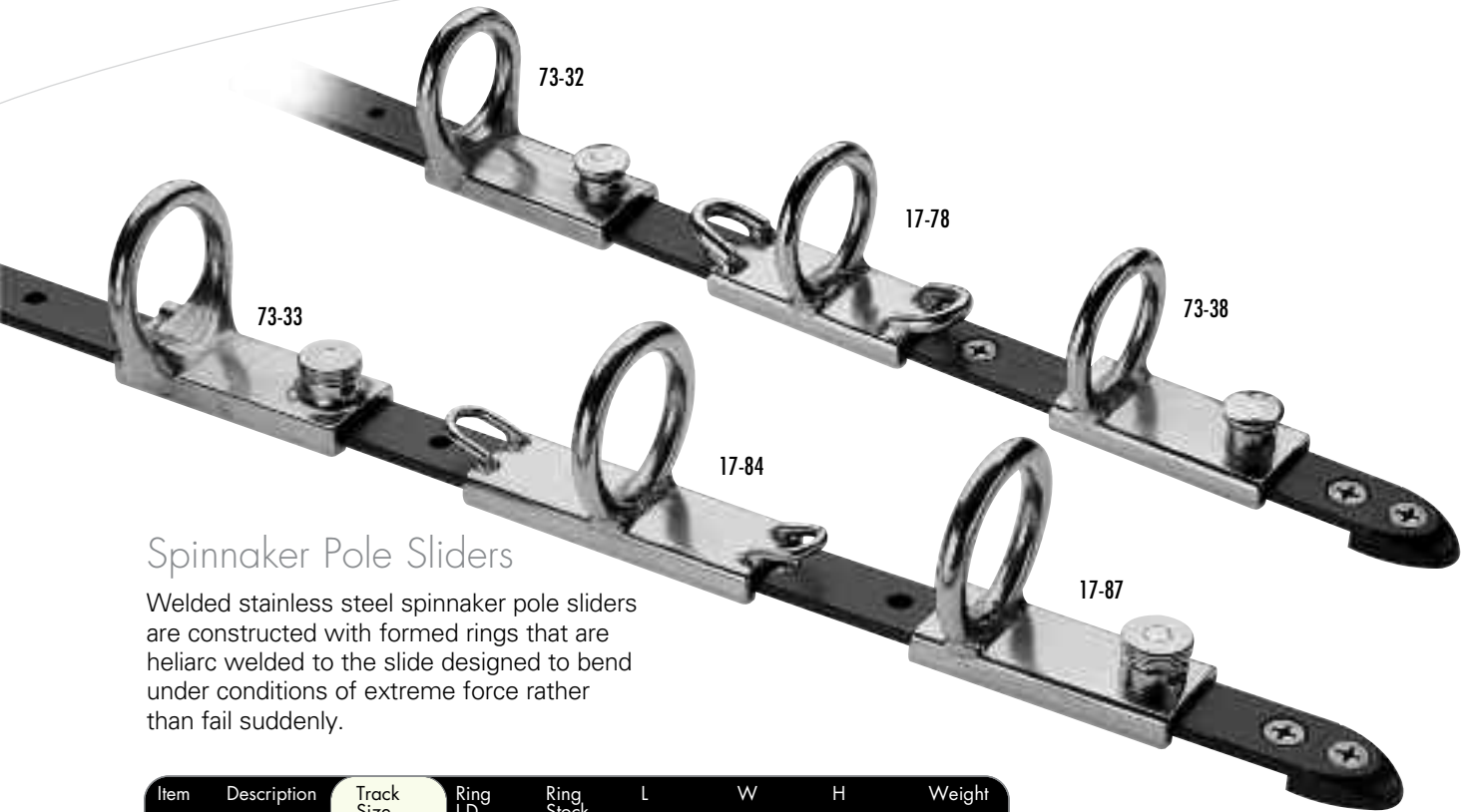

## Spinnaker Pole Sliders

Welded stainless steel spinnaker pole sliders are constructed with formed rings that are heliarc welded to the slide designed to bend under conditions of extreme force rather than fail suddenly.

Item	Description	Track Size	Ring I.D.	Ring Stock	L	W	H	Weight
73-32	Investment Cast	1" x 1/8" (25mm x 3mm)	1-3/16" (30mm)	11/32" (9mm)	3" (76mm)	2-7/32" (56mm)	2-7/16" (62mm)	4.5 oz. (128g)
17-78	Towable/ Lined	1" x 1/8" (25mm x 3mm)	1-1/2" (39mm)	7/16" (11mm)	5-5/16" (135mm)	2-29/32" (74mm)	3-1/4" (83mm)	14 oz. (397g)
73-38	Welded/ Lined	1" x 1/8" (25mm x 3mm)	1-1/4" (32mm)	1/4" (6mm)	3" (76mm)	2-1/8" (54mm)	2-5/16" (58mm)	4 oz. (113g)

Item	Description	Track Size	Ring I.D.	Ring Stock	L	W	H	Weight
73-33	Investment Cast	1-1/4" x 3/16" (32mm x 5mm)	2" (51mm)	7/16" (11mm)	4-1/4" (108mm)	2-7/8" (73mm)	3-5/32" (80mm)	8 oz. (227g)
17-84	Towable/ Lined	1-1/4" x 3/16" (32mm x 5mm)	2" (51mm)	7/16" (11mm)	5-5/16" (135mm)	2-29/32" (74mm)	3-1/4" (83mm)	14 oz. (397g)
17-87	Welded/ Lined	1-1/4" x 3/16" (32mm x 5mm)	2" (51mm)	7/16" (11mm)	5-5/16" (135mm)	2-29/32" (74mm)	3-1/4" (83mm)	1 lb. (453g)

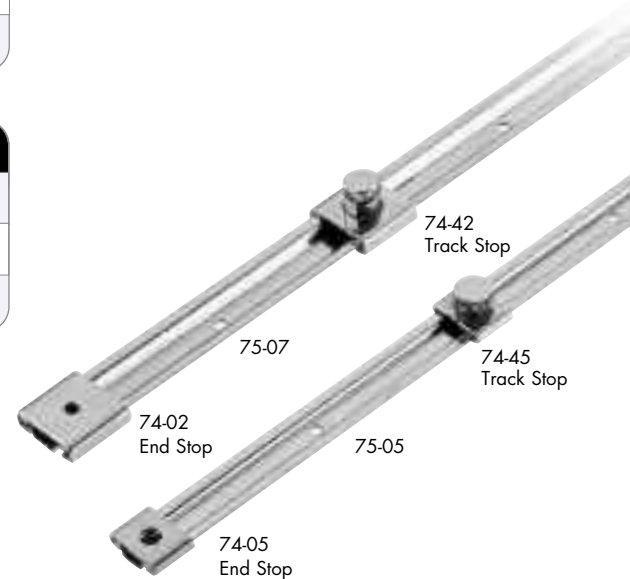

## Stainless Sail Track

Constructed of type 304 Stainless Steel. Used on masts and booms for high strength sail leads.

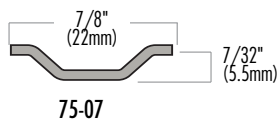
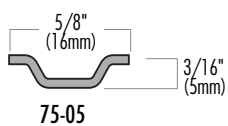

Item	Track Size	Track Type	Length	Fastener Size	Fastener Spacing	Weight/ Foot	End Stop	Track Stop
75-05-72"	5/8" (16mm)	Stainless	6' (1.8m)	#6 RH (3.5mm)	2-3/4" (70mm)	2-1/2 oz. (71g)	74-05	74-45
75-05-144"	5/8" (16mm)	Stainless	12' (3.6m)	#6 RH (3.5mm)	2-3/4" (70mm)	2-1/2 oz. (71g)	74-05	74-45
75-07-72"	7/8" (22mm)	Stainless	6' (1.8m)	#8 RH (4mm)	2-3/4" (70mm)	3 oz. (85g)	74-02	74-42
75-07-144"	7/8" (22mm)	Stainless	12' (3.6m)	#8 RH (4mm)	2-3/4" (70mm)	3 oz. (85g)	74-02	74-42

# Cleats / Chocks

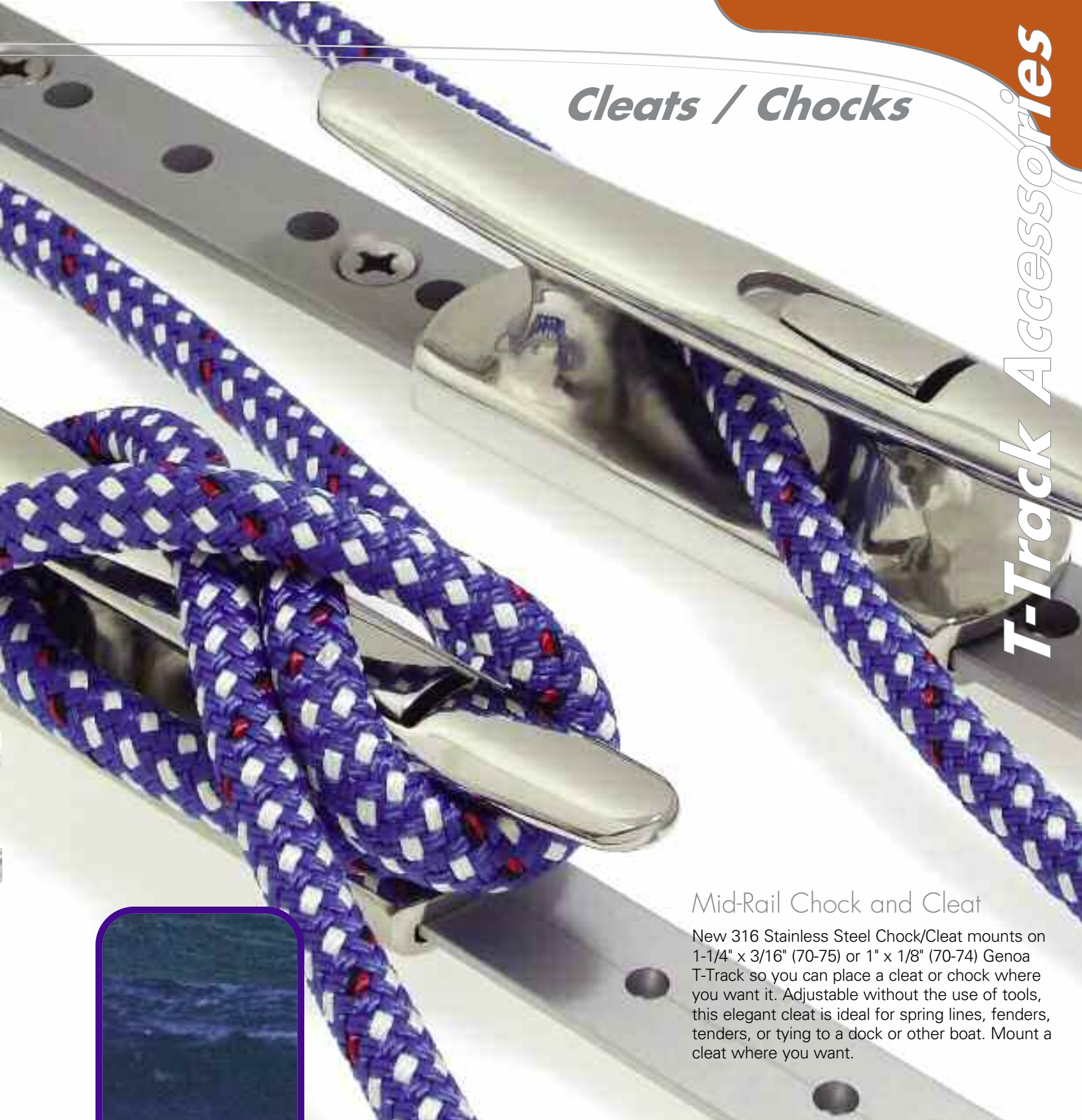

## Mid-Rail Chock and Cleat

New 316 Stainless Steel Chock/Cleat mounts on 1-1/4" x 3/16" (70-75) or 1" x 1/8" (70-74) Genoa T-Track so you can place a cleat or chock where you want it. Adjustable without the use of tools, this elegant cleat is ideal for spring lines, fenders, tenders, or tying to a dock or other boat. Mount a cleat where you want.

Item Stain.	Description	L	ID	Line Size	Track	Pin Size	SWL	Weight
70-74	Mid-Rail Chock/Cleat	6-1/2" (165mm)	1-7/16" (180mm)	1/2" (13mm)	1" x 1/8" (25mm x 3mm)	1/4" (6mm)	2500 lbs. (1140kg.)	.9 lb. (41kg.)
70-75	Mid-Rail Chock/Cleat	7-1/2" (190mm)	1-3/4" (45mm)	5/8" (16mm)	1-1/4" x 3/16" (31mm x 4.6mm)	5/16" (9mm)	4500 lbs. (2045kg.)	1.5 lbs. (.68kg.)

# Stainless Steel Deck Cleats



### Stainless Steel Deck Cleats:

- Smooth, Generous Radius Edges Reduce Line Chafe
- Large Throat Allows Loops To Pass Through
- Wide Base Distributes Load
- Recess For Bedding To Provide Watertight Seal
- Hidden Metric Studs, Washers, Nuts And Backing Plate included

Schaefer's Stainless Steel Deck Cleats are a combination of form, function and strength. Using Electropolished 316 Stainless Steel and incorporating a unique Hidden Metric Fastener design. This results in a Cleat that is clean, strong and engineered to Schaefer's Legendary standards.



## Deck Cleats

Item	Description	Max Line Size	Length	Height	Stud Size	Stud Ctr-to-Ctr	Deck Thickness Max.	Min.	Weight including all hardware
70-200	8.0" Deck Cleat 316 Stainless Steel	5/8" (16 mm)	8.0" (203 mm)	1.5" (38 mm)	M14	2.81" (71 mm)	1.44 (37 mm)	.50" (13 mm)	.96 lb. (.80 kg)
70-250	10.0" Deck Cleat 316 Stainless Steel	3/4" (19 mm)	10.0" (254 mm)	1.80" (46 mm)	M16	3.28" (83 mm)	1.87" (48 mm)	.63" (16 mm)	2.21 lb. (1.24 kg)
70-315	12.5" Deck Cleat 316 Stainless Steel	1.0" (25 mm)	12.5" (318 mm)	2.4" (61 mm)	M20	4.38" (111 mm)	2.25" (57 mm)	.81" (21 mm)	4.47 lb. (2.75 kg)

# Stainless Steel XCL Bow Chocks

Stainless Steel Cleats & Chocks



Schaefer's Stainless Steel Bow Chocks provide a smooth lead for your mooring or dock lines. Our unique design features a narrow jaw to keep lines in place, a deep opening to accept chafe gear and a thick base to keep lines off of your deck. The generous radius edges reduce chafe to a minimum. Combine this with our unique hidden Metric fastener design and a brilliant electropolished 316 Stainless Steel finish for strength and beauty.

### Bow Chocks:

- Smooth, Generous Radius Edges Reduce Line Chafe
- Deep Opening Accepts Mooring Lines With Chafe Gear
- Narrow Jaw Opening Designed To Keep Mooring Lines Securely In Place
- Recess For Bedding To Provide Watertight Seal
- Hidden Metric Fasteners And Backing Plate Included

## XCL Bow Chocks

Item	Description	Max Line Size	Length	Width	Height	Stud Size	Stud Ctr-to-Ctr	Deck Thickness Max.	Deck Thickness Min.	Weight including all hardware
60-40	4" Bow Chock 316 Stainless Steel	5/8" (16 mm)	4.0" (102 mm)	1.0" (25 mm)	1.75" (44 mm)	M10	2.87" (73 mm)	1.38" (35 mm)	.31" (8 mm)	.96 lb. (.44 kg)
60-50	5.25" Bow Chock 316 Stainless Steel	3/4" (19 mm)	5.25" (133 mm)	1.50" (38 mm)	2.16" (55 mm)	M12	3.75" (95 mm)	1.88" (48 mm)	.38" (10 mm)	2.21 lb. (1 kg)
60-60	6.75" Bow Chock 316 Stainless Steel	1.0" (25 mm)	6.75" (171 mm)	2.0" (51 mm)	2.75" (70 mm)	M14	5" (127 mm)	2.44" (62 mm)	.44" (12 mm)	4.47 lb. (2.03 kg)

Call 508-995-9511 for Customer Service

**SCHAEFER**  
LEGENDARY STRENGTH



# Universal Deck Mount

Schaefer's unique Deck Mounting system allows you the flexibility you've always wanted on your deck. Whether you need a cleat, padeye, block or need a flush deck while underway this one mount will do the job.

Our elegant Stainless Steel cleat locks in place with a 1/4 turn and push. Remove by lifting the two flush release levers and again turning. You may then replace the cleat with a screw-in Stainless Steel eye that is ideal for tie downs, dinghies, safety gear, life rafts or anything else you can think of! Our Stainless Series 8 Stand-up Block is ideal for use as an afterguy or any line that needs a clean, strong lead.



**78-77 Stainless Deck Plate with Delrin™ Plug, and Backing Plate**  
 3-15/16" (100mm) x 3-1/8" (79mm) Hole diameter in boat 1-3/4" (44mm) Hole depth in Boat 1-3/32" (33mm)

**70-77 Stainless Deck Cleat/Chock**  
 8.5" 1/4 turn index locking feature C/C 1-15/16" (49mm) x 2" (51mm) Height = 2-3/32" (53mm)  
 Backing Plate is 3-3/8" (86mm) x 3-5/16" (84mm) SWL: 4200 lbs.

**78-76 Stainless Screw Eye**  
 Height = 1-23/32" (44mm) SWL: 4200 lbs.

**08-77 Stainless Swivel Series 8 Single Block**  
 Spring mounted, on 1"-12 threaded stainless steel plug. Height = 4-5/8" (119mm) SWL: 2750 lbs.

**NEW M66-07 Screw In Deck Block (See Page 5)**  
 Spring mounted, on 1"-12 threaded stainless steel plug. Height = 4-5/8" (119mm) SWL: 2750 lbs.

**NEW M82-07 Screw In Deck Block (See Page 6)**  
 Spring mounted, on 1"-12 threaded stainless steel plug. Height = 4-5/8" (119mm) SWL: 2750 lbs.

- Universal Deck Cleat:**
- Removable S.S. Deck Cleat
  - Optional S.S. Screw Eye
  - Optional 8 Series Stand-Up Block
  - 316 S.S. Construction



**SCHAEFER**  
 LEGENDARY STRENGTH

[www.SchaeferMarine.com](http://www.SchaeferMarine.com)

# Stainless Steel Open Base Cleats



### Stainless Steel Open Base Cleats:

- Smooth, Generous Radius Edges Reduce Line Chafe
- Large Throat Allows Loops To Pass Through Open Base
- Counter Sunk Holes For Flush Fastening And Urethane Washers Included

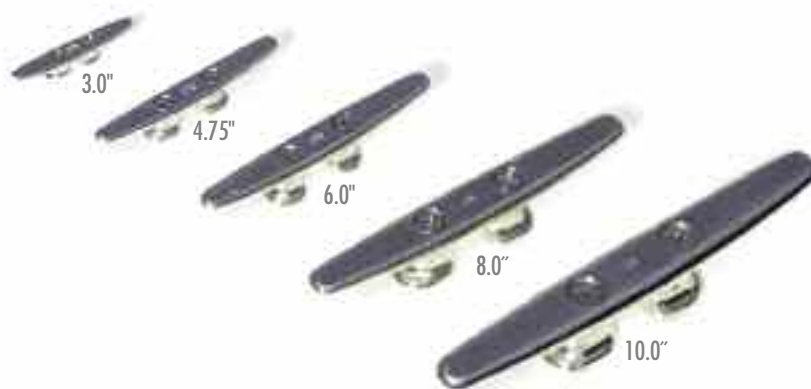

Schaefer's new Stainless Steel Open Base Cleats are a combination of form, function and strength. Using Electropolished 316 Stainless Steel and incorporating counter-sunk holes for flush mount fasteners. Urethane washers keep dissimilar metals apart and generous radiused edges keep line chafe to a minimum.

## Open Base Cleats

Item	Description	Max Line Size	Length	Height	Fastener Size	Fastener Ctr-to-Ctr	Weight
60-75	3.0" Open Base Cleat 316 Stainless Steel	1/4" (6 mm)	3.0" (76 mm)	0.2" (15 mm)	#8 F.H.	0.78" (20 mm)	1.3 oz. (.04 kg)
60-120	4.75" Open Base Cleat 316 Stainless Steel	3/8" (10 mm)	4.75" (120 mm)	0.9" (23 mm)	#10 F.H.	1.25" (32 mm)	4.1 oz. (.12 kg)
60-150	6.0" Open Base Cleat 316 Stainless Steel	1/2" (13 mm)	6" (152 mm)	1.2" (30 mm)	1/4" F.H.	1.50" (38 mm)	9.0 oz. (.26 kg)
60-200	8.0" Open Base Cleat 316 Stainless Steel	5/8" (16 mm)	8.0" (203 mm)	1.5" (38 mm)	5/16" F.H.	2.0" (51 mm)	1.3 lb. (.59 kg)
60-250	10.0" Open Base Cleat 316 Stainless Steel	3/4" (19 mm)	10.0" (254 mm)	1.8" (46 mm)	3/8" F.H.	2.50" (64 mm)	2.3 lb. (1.04 kg)

# Aluminum Cleats

These tough cleats are anodized to provide the strength and corrosion resistance you need for years of reliable service. Strong, yet lightweight aluminum offers an advantage over easily "burned-out" plastic or heavy stainless designs. Our smooth edges protect your lines from chafe and wear and accept large diameter lines that are easier on tired hands.

## Low Profile

Extra low profile designs are ideal for limited space applications or for use on spars to reduce windage and fouled lines.

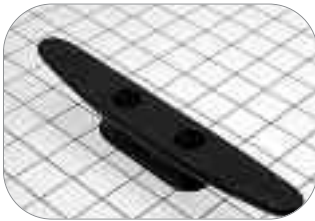

70-16

Item Silver	Item Black	Descrip.	Length	Line Score	Fasteners	C/C A	Weight
60-14	70-14	Low Profile	4" (102mm)	3/8" (10mm)	(2) #10 FH (5mm)	1" (25mm)	1 oz. (28g)
60-16	70-16	Low Profile	6" (152mm)	5/8" (16mm)	(2) 1/4" FH (6mm)	1-1/2" (38mm)	3.5 oz. (99g)

## Open Base

Helps prevent loose halyard ends from running up the mast. Line ends can be inserted through "open" base and knotted for an easily grabbed dead end.



60-96

Item Silver	Item Black	Descrip.	Length	Line Score	Fasteners	C/C A	Weight
60-94	70-94	Open Base	4" (102mm)	3/8" (10mm)	(2) #10 FH (5mm)	1" (25mm)	1.5 oz. (43g)
60-95	70-95	Open Base	5" (127mm)	1/2" (13mm)	(2) #12 FH (6mm)	1-1/4" (32mm)	2 oz. (57g)
60-96	70-96	Open Base	6" (152mm)	5/8" (16mm)	(2) 1/4" FH (6mm)	1-1/2" (38mm)	3.5 oz. (99g)
60-98	70-98	Open Base	8" (203mm)	5/8" (16mm)	(2) 5/16" FH (8mm)	2" (51mm)	8.5 oz. (240g)

## Self Jamming

Excellent for use with genoa sheets or reefing lines. One "wrap" around our "V" shaped base section locks line in cleat for quick adjustments.



70-80

Item Silver	Item Black	Descrip.	Length	Line Score	Fasteners	C/C A	Weight
60-78	70-78	Self Jamming	4" (102mm)	5/16" (8mm)	(2) #10 FH (5mm)	1-1/16" (27mm)	1.5 oz. (43g)
60-79	70-79	Self Jamming	5" (127mm)	3/8" (10mm)	(2) #12 FH (6mm)	1-5/16" (33mm)	2.5 oz. (71g)
60-80	70-80	Self Jamming	6" (152mm)	1/2" (13mm)	(2) 1/4" FH (6mm)	1-1/2" (38mm)	4 oz. (113g)

## Four Hole Deck

Large base design spreads heavy loads for dock, mooring, or anchor line use.



60-06

Item Silver	Item Black	Descrip.	Length	Line Score	Fasteners	C/C Long	CC Across	Weight
60-06	70-06	Four Hole Deck	6" (152mm)	7/16" (11mm)	(4) 1/4" FH (6mm)	1-1/2" (38mm)	1-11/16" (43mm)	5.5 oz. (156g)
60-08	70-08	Four Hole Deck	8" (203mm)	3/4" (19mm)	(4) 5/16" FH (8mm)	2" (51mm)	2" (51mm)	11.5 oz. (326g)
60-10	70-10	Four Hole Deck	10" (254mm)	7/8" (22mm)	(4) 3/8" FH (10mm)	2-1/2" (63mm)	2-1/2" (63mm)	1 lb. 5 oz. (595g)

# Stainless Hardware



78-83

## Removable Eye Deck Plate

Welded eye screws into stainless deck plate allowing for easy attachment and removal of snap shackles, snatch blocks, or lashing straps. When not needed, remove eye and replace with high impact Delrin™ screw to fill and protect the threads. Deck plate will accept 704-12 adapter for use with 7 Series Blocks.

Item	Descrip.	Eye Width	Eye Height	Eye Stock	L	W	Fasteners	C/C A	C/C B	SWL	Weight
78-81	Deck Plate Only	---	---	---	2-1/2" (64mm)	2-1/2" (64mm)	(4) 1/4" FH (6mm)	2" (51mm)	2" (51mm)	---	6 oz. (170g)
78-81-02	Delrin™ Plug Only	---	---	---	---	---	---	---	---	---	.5 oz. (14g)
78-82	S.S. Eye	---	---	1/4" (6mm)	---	---	---	---	---	---	3 oz. (85g)
78-83	Remov. Eye/Assembly*	5/8" (16mm)	5/8" (16mm)	1/4" (6mm)	2-1/2" (64mm)	2-1/2" (64mm)	(4) 1/4" FH (6mm)	2" (51mm)	2" (51mm)	2250lbs. (1020kg)	9.5 oz. (269g)

\*Requires 1" (25mm) dia. x 3/4" (19mm) deep recessed hole in deck.



**WARNING**  
Extreme care should be taken in mounting Stanchion bases securely to the deck. Please contact Schaefer for more information.

## Heavy-Duty Stanchions and Accessories

These single or double 1" (25mm) dia. stanchions are offered in both 24" (610mm) or 26" (660mm) versions and accept coated wire up to 5/16" (8mm) dia. Rugged stainless base is canted 5° inboard to match most deck cambers and features a 5/16" (8mm) welded rod reinforcement which also serves as a bail for snatch blocks and other gear.

Item Single	Item Double	Descrip.	L	W	T	Fasteners	Weight
36-01	(use 36-01)	Stanchion Base	5-1/8" (130mm)	2-3/4" (70mm)	1" (25mm)	(4) 1/4" (6mm)	14 oz. (397g)
36-07	36-17	26" Stanchion Tube	26" (660mm)	1" (25mm)	1/16" (1.5mm)	---	1 lb. 6 oz. (624g)
36-08	36-18	24" Stanchion Tube	24" (610mm)	1" (25mm)	1/16" (1.5mm)	---	1 lb. 3 oz. (539g)
36-09*	(use 36-09)	Gate Brace	20-7/8" (530mm)	1" (25mm)	3/8" (10mm)	---	12 oz. (340g)
---	36-04	Double/Stanchion Ring	1-5/8" (41mm)	1" (25mm)	---	---	2 oz. (57g)
36-91	---	Backing Plate	5-1/8" (130mm)	2-3/4" (70mm)	1/16" (1.5mm)	---	2 oz. (57g)

\*Optional, stainless gate brace mounts 20 7/8" (530mm) high on stanchion with a welded base canted 60° to offer additional support of gate openings. Double stanchion ring accepts up to 5/16" (8mm) dia. wire for retrofitting double lifeline set-ups and mounts to 1" (25mm) stanchion with integral set screws.



36-01 Stanchion Base  
36-91 Backing Plate



36-04  
Stanchion ring fits 1" stanchion accepting 2nd lifeline

36-17



36-09

36-01

36-91  
Backing Plate

36-09

# FAST ENTRY CAM CLEATS



70-07



70-17



70-27

Part #	Description	Line Size Range	Height	Length	Width	Weight	Safe Working Load	C/C Fastener
70-07	Fast Entry Cam Cleat	1/8" (3mm) - 1/4" (6mm)	7/8" (22mm)	1-13/16" (46mm)	7/8" (22mm)	0.8oz (22g)	200 lbs (91kg)	1-1/16" (26mm) #8 FH
70-17	Fast Entry Cam Cleat	1/4" (6mm) - 7/16" (12mm)	1-3/16" (30mm)	2-1/2" (63mm)	1-3/16" (30mm)	2.12oz (68g)	300 lbs (135kg)	1-1/2" (38mm) #10 FH
70-27	Fast Entry Cam Cleat	1/4" (6mm) - 5/8" (16mm)	1-1/2" (38mm)	3-1/4" (82mm)	1-3/8" (35mm)	4.8oz (136g)	500 lbs (227kg)	2-1/16" (52mm) 1/4" FH

## Fast Entry Cam Cleat Accessories

Part #	Description	Works with
77-07-BLK	Fairlead - Black	70-07
77-07-BLU	Fairlead - Blue	70-07
77-07-GRN	Fairlead - Green	70-07
77-07-RED	Fairlead - Red	70-07
77-07-YEL	Fairlead - Yellow	70-07
77-08	Wire Fairlead with Base	70-07
77-17-BLK	Fairlead - Black	70-17
77-17-BLU	Fairlead - Blue	70-17
77-17-GRN	Fairlead - Green	70-17
77-17-RED	Fairlead - Red	70-17
77-17-YEL	Fairlead - Yellow	70-17
77-18	Wire Fairlead with Base	70-17



77-18



70-17 with 77-18

# Cam Cleats

## "Sure-Grip" Cam Cleats

Schaefer's "Sure-Grip" Cam Cleats are made from investment cast stainless steel that won't wear out or corrode. Similar competitor designs use either plastic composites which can dull as a result of heat buildup, or die cast aluminum which has a higher potential for corrosion.

Our computer designed flared jaws allow lines to "drop in" without pulling for quick engagement and release while the open top and removable fasteners allow flushing and disassembly for easy maintenance.



70-28



70-29



70-38



70-39

Item	Description	Max Line Size	Fastener* Size	C/C	L	W	H	SWL	Weight
70-28 70-29	Small Cam/Wire Fairlead Small Cam/Eye Strap	7/16" (11mm)	(2)#10 RH (5mm)	1-1/2" (38mm)	2-11/16" (68mm)	1-13/32" (36mm)	15/16" (24mm)	500 lbs. (225kg)	4.5 oz. (114g)
70-38 70-39	Large Cam/Wire Fairlead Large Cam/Eye Strap	5/8" (16mm)	(2)#10 RH (5mm)	1-25/32" (45mm)	3-3/16" (81mm)	1-11/16" (43mm)	1-1/8" (28mm)	500 lbs. (225kg)	7 oz. (178g)



## Swivel Cam Bases

Schaefer's Swivel Cam Base features our Fast Entry Cam Cleat for quick and easy line engagement from a variety of angles. The Stainless Steel arm is ideal for dinghys or daysailors.



70-61

**If you are in doubt as to the suitability of your selection please contact Schaefer for assistance.**

Item	Description	Max Line Size	Fastener* Size	C/C	L	W	H	SWL	Weight
70-61	Small Cam/ Swivel Base	7/16" (11mm)	(3)#10 RH (5mm)	1" (25mm)	3-1/4" (83mm)	2" (50mm)	2" (50mm)	300 lbs. (135kg)	6.5 oz. (184g)

# Stainless Hardware

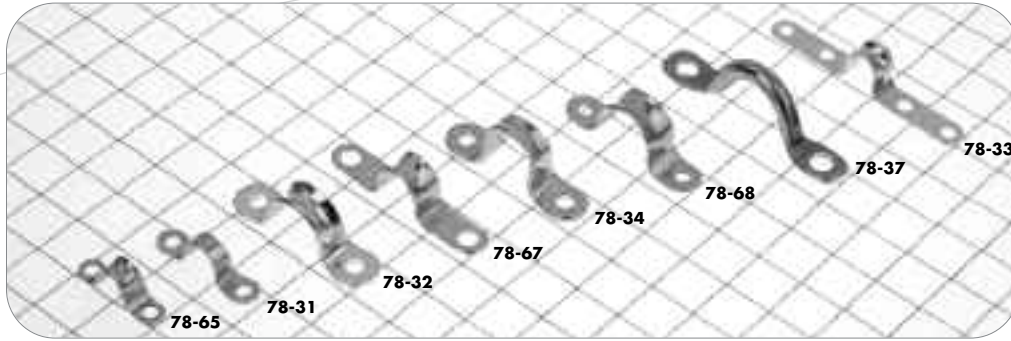

## Eye Straps

Schaefer's eye straps are manufactured from high quality Stainless Steel. Choose from our Narrow Saddle or Thimbled models to suit your needs.

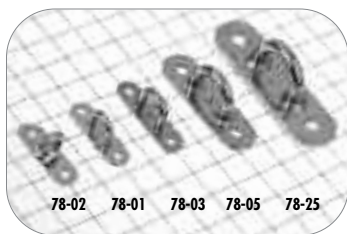
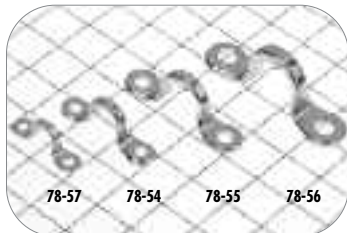

Thimbled Eye Straps

Item	Descrip.	Eye Width	Eye Height	L	W	Fasteners	C/C	SWL	Weight
78-65	Eye Strap Stamped	9/32" (11mm)	9/32" (10mm)	1-7/16" (37mm)	1/4" (8mm)	(2) #10 RH (5mm)	1" (25mm)	400 lbs (181 kg)	.5 oz. (14g)
78-31 *78-66	Eye Strap Stamped	7/16" (11mm)	3/8" (10mm)	1-7/16" (37mm)	5/16" (8mm)	(2) #10 RH (5mm)	1-1/8" (29mm)	400 lbs. (181kg)	.5 oz. (14g)
78-32	Eye Strap Stamped	1/2" (13mm)	1/2" (13mm)	1-3/4" (44mm)	5/16" (8mm)	(2) #10 RH (5mm)	1-5/16" (33mm)	400 lbs. (181kg)	.5 oz. (14g)
78-67	Stamped	5/8" (16mm)	5/8" (16mm)	(52mm)	1/2" (13mm)	(5mm)	(40mm)	400 lbs (181kg)	.5 oz (14g)
78-34	Eye Strap Stamped	5/8" (16mm)	5/8" (16mm)	2-3/4" (70mm)	1/2" (13mm)	(2) 1/4" RH (6mm)	2-3/16" (56mm)	800 lbs. (363kg)	.5 oz. (14g)
78-68	Stamped	5/8" (16mm)	3/4" (19mm)	2-3/8" (60mm)	5/8" (16mm)	7/32" (6mm)	1-3/4" (44mm)	800 lbs. (363kg)	1 oz. (28g)
78-38	Eye Strap Stamped	11/16" (17mm)	7/8" (22mm)	2-7/16" (62mm)	5/8" (16mm)	(2) #10 RH (6mm)	1-13/16" (46mm)	400 lbs. (181kg)	.5 oz. (14g)
78-37	Eye Strap 5/16 Rod	1" (25mm)	3/4" (19mm)	3-1/2" (89mm)	5/16" (8mm)	(2) 5/16" RH (8mm)	2-1/2" (64mm)	1000 lbs. (545kg)	1.5 oz. (43g)
78-33	Eye Strap Stamped	9/16" (14mm)	7/16" (11mm)	3-1/8" (79mm)	3/8" (10mm)	(4) #10 RH (5mm)	**2-11/16" (67mm)	400 lbs. (181kg)	.5 oz. (14g)

\*\*78-33 inside c/c is 3/4" (19mm)

Narrow Saddle Eye Straps

Item	Descrip.	Eye Width	Eye Height	L	W	Fasteners	C/C	SWL	Weight
78-57	Narrow Saddle Eye Strap	7/16" (11mm)	7/16" (11mm)	1-3/16" (35mm)	5/32" (4mm)	(2) #8 RH (4mm)	1" (25mm)	300 lbs. (136 kg)	.5 oz. (14g)
78-54	Narrow Saddle Eye Strap	5/8" (16mm)	5/8" (16mm)	1-13/16" (46mm)	3/16" (5mm)	(2) #10 RH (5mm)	1-3/8" (35mm)	600 lbs. (272 kg)	.5 oz. (14g)
78-55	Narrow Saddle Eye Strap	3/4" (19mm)	3/4" (19mm)	2-5/16" (59mm)	7/32" (6mm)	(2) #1/4" RH (6mm)	1-3/4" (44mm)	1000 lbs (545 kg)	1oz. (28g)
78-56	Narrow Saddle Eye Strap	7/8" (22mm)	7/8" (22mm)	2-13/16" (71mm)	9/32" (7mm)	(2) 5/16" RH (8mm)	2-1/8" (54mm)	1500 lbs (682 kg)	1 oz. (28g)

\*Denotes New Part Numbers

## Welded Ring Pad Eyes

Our Welded Ring Pad Eyes are fabricated from high quality Stainless Steel rod with stamped bases. Thick diameter rings and welded construction provide high strength and durability. Backing Plates are sold separately. Refer to chart below for ordering information.

Welded Pad Eyes

Item	Descrip.	Backing Plate	Eye Width	Eye Height	Eye Stock	L	W	Fasteners	C/C A	SWL B	Weight
78-02	Welded/Side Ring	---	3/8" (10mm)	3/8" (10mm)	3/16" (5mm)	1-7/8" (48mm)	5/8" (16mm)	(2) #10 RH (5mm)	1-5/16" (33mm)	250 lbs. (115kg)	.5 oz. (14g)
78-01	Welded/Ring	97-51	7/8" (22mm)	7/8" (22mm)	1/4" (6mm)	3" (76mm)	1" (25mm)	(2) 1/4" RH (6mm)	2-3/16" (55mm)	2500 lbs. (1135kg)	3.25 oz. (92g)
78-03	Welded/Ring	---	1/2" (13mm)	1/2" (13mm)	3/16" (5mm)	2" (51mm)	5/8" (16mm)	(2) #10 RH (5mm)	1-7/16" (37mm)	650 lbs. (295kg)	.5 oz. (14g)
78-05	Welded/Ring	---	1/2" (13mm)	1/2" (13mm)	1/4" (6mm)	2-1/4" (57mm)	5/8" (16mm)	(2) #10 RH (5mm)	1-11/16" (42mm)	750 lbs. (340kg)	1.75 oz. (50g)
78-25	Welded/Ring	78-26	1" (25mm)	1" (25mm)	5/16" (8mm)†	4-1/4" (108mm)	1-1/4" (32mm)	(2) 3/8" RH (10mm)	3-1/16" (77mm)	3000 lbs. (1350kg)	6 oz. (170g)

# Stainless Hardware

## Investment Cast Pad Eyes

These heavy-duty pad eyes are investment cast from high quality Stainless Steel for a high degree of accuracy and strength. The first step in this process involves making a wax part from a master or permanent die. The wax part is then used in a temporary or series of temporary molds. The actual parts are then cast from the molds without any

wear to the permanent die to ensure accurate casting each time. Backing Plates are from high quality stainless steel and are sold separately. Refer to chart below for ordering information.

Schaefer x-rays all of our investment cast pad eyes to ensure a safe finished product is on your boat.

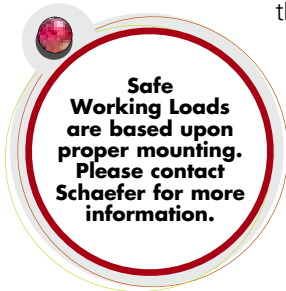

78-17



78-96



78-98



97-42

Item	Descrip.	Backing Plate	Eye Width	Eye Height	Eye Stock	L	W	Fasteners	C/C A	C/C B	SWL	Weight
78-07	Inv. Cast/ Rnd Base	97-53	1" (25mm)	13/16" (21mm)	3/8" (10mm)	2-1/2" (64mm)	2-1/2" (64mm)	(4) 1/4" (FH6mm)	1" (25mm)	1-1/2" (38mm)	4000 lbs. (1800kg)	4 oz. (113g)
78-17	Inv. Cast/ Rnd Base	97-54	1-1/8" (29mm)	7/8" (22mm)	1/2" (13mm)	3" (76mm)	3" (76mm)	(4) 3/8" (FH10mm)	1-1/8" (29mm)	1-11/16" (43mm)	8500 lbs. (3800kg)	12 oz. (340g)
78-95	Inv. Cast/ Diamd. Base	97-57	3/4" (19mm)	7/16" (11mm)	5/16" (8mm)	3-1/8" (79mm)	2" (4) (51mm)	(4) 1/4" (FH6mm)	2-13/32" (61mm)	1-1/4" (32mm)	4000 lbs. (1800kg)	5 oz. (142g)
78-96	Inv. Cast/ Diamd. Base	97-56	1" (25mm)	5/8" (16mm)	3/8" (10mm)	4" (102mm)	2-3/8" (4) (60mm)	(4) 1/4" (FH6mm)	3" (76mm)	1-9/16" (40mm)	4400 lbs. (2000kg)	8.5 oz. (241g)
78-98	Inv. Cast/ Oblong Base	97-58	5/8" (16mm)	1/2" (13mm)	5/16" (8mm)	3" (76mm)	15/16" (24mm)	(2) 1/4" (FH6mm)	2-3/32" (53mm)	---	2200 lbs. (1000kg)	4 oz. (113g)
78-99	Inv. Cast/ Oblong Base	78-26	7/8" (22mm)	3/4" (19mm)	7/16" (11mm)	4" (102mm)	1-3/8" (35mm)	(2) 5/16" (FH8mm)	2-7/8" (73mm)	---	3500 lbs. (1600kg)	10 oz. (284g)
97-42	Inv. Cast/ Sq'r Base	97-52	3/4" (19mm)	3/4" (19mm)	5/16" (8mm)	3" (76mm)	3" (76mm)	(4) 1/4" (FH6mm)	2" (51mm)	2" (51mm)	4000 lbs. (1800kg)	11 oz. (312g)

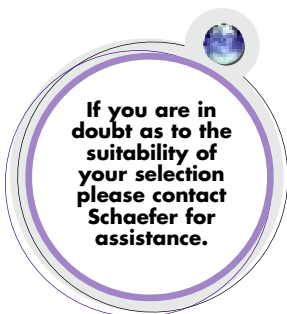

## Bow Eye / Lifting Ring

Choose from our Stainless Steel Bow Eye or Lifting Ring for applications requiring a high quality attachment.



78-22



78-71

Item	Descrip.	Eye Width	Eye Height	Eye Stock	L	W	Fasteners	C/C A	C/C B	SWL	Weight
78-71	Bow Eye/ Cvrd. Base*	3/4" (19mm)	1/2" (13mm)	1/4" (6mm)	1-3/4" (44mm)	5/8" (16mm)	1" 1/4-20 Rod (25mm, 6mm)	1" (25mm)	---	2000 lbs. (900kg)	1.75 oz. (50g)
78-22	Lifting Ring/ Strap Base	1-3/8" (35mm)	1-3/8" (35mm)	5/16" (8mm)	3-1/2" (92mm)	3/4" (16mm)	(4) #10 FH (5mm)	2-3/4" (48mm)	11/16" (19mm)	1000 lbs. (450kg)	4 oz. (113g)

\*Stainless bow eye has curved base to fit small boat stems.



# Rigging Pins



## Clevis Pins

Stainless Steel Clevis Pins in a variety of sizes.

Item	Diameter	Grip
98-01	3/16" (5mm)	21/32" (17mm)
98-02	1/4" (6mm)	3/4" (19mm)
98-03	1/4" (6mm)	1-1/16" (27mm)
98-04	1/4" (6mm)	15/16" (24mm)
98-05	3/16" (5mm)	5/8" (16mm)
98-06	3/16" (5mm)	1/4" (6mm)
98-07	3/16" (5mm)	3/8" (10mm)
98-08	1/4" (6mm)	7/16" (12mm)
98-10	3/8" (10mm)	9/16" (14mm)
98-11	1/4" (6mm)	1/2" (13mm)
98-12	5/16" (8mm)	5/8" (16mm)
98-13	7/16" (12mm)	7/8" (22mm)
98-14	3/8" (10mm)	25/32" (20mm)
98-15	1/2" (13mm)	1-1/32" (26mm)
98-16	5/8" (16mm)	1-5/16" (33mm)
98-17	5/8" (16mm)	1-1/32" (26mm)
98-21	3/8" (10mm)	1-3/32" (27mm)

**If you have any questions about your choices, contact Schaefer for assistance.**

## Quick Release Pins

One hand release! Just pull to release the pin. Made from 316 S.S. for corrosion resistance and strength.

Item	Diameter	Grip
98-1805	3/16" (5mm)	1/2" (13mm)
98-1810	3/16" (5mm)	1" (25mm)
98-1815	3/16" (5mm)	1-1/2" (38mm)
98-2505	1/4" (6mm)	1/2" (13mm)
98-2510	1/4" (6mm)	1" (25mm)
98-2515	1/4" (6mm)	1-1/2" (38mm)
98-2520	1/4" (6mm)	2" (51mm)
98-3110	5/16" (8mm)	1" (25mm)
98-3115	5/16" (8mm)	1-1/2" (38mm)
98-3120	5/16" (8mm)	2" (51mm)
98-3710	3/8" (10mm)	1" (25mm)
98-3715	3/8" (10mm)	1-1/2" (38mm)
98-3720	3/8" (10mm)	2" (51mm)
98-3725	3/8" (10mm)	2-1/2" (64mm)



# Rigging Accessories

## Sail Pre-Feeders

Compatible with all systems, our Pre-Feeder is helpful if you intend to change sails or sail shorthanded. Aligns your luff tape before it enters into the Stainless Steel feeder on the extrusion foil. Welded bail allows for shock cord or line attachment to keep the feeder close to the headstay.



1205-01



1205-11



76-30

Item	Descrip.	Const.	Max Luff Tape	L	W	T	Weight
1205-01	Genoa Prefeeder	S.S. & Bronze	#5-#8 Luff Tape 5/32"-1/4" (4mm-7mm)	2-5/16" (59mm)	2" (51mm)	5/8" (16mm)	3.2oz. (.09kg)
1205-11	Mainsail Prefeeder	S.S. & Bronze	1/4"-1/2" Bolt Rope (6mm-13mm)	2-5/16" (59mm)	2" (51mm)	2" (51mm)	4 oz. (10g)
76-30	Genoa Prefeeder	Stainless Steel	#5-#8 Luff Tape 5/32"-1/4" (4mm-7mm)	2-1/8" (54mm)	2-1/8" (54mm)	5/16" (8mm)	2 oz. (.05g)



76-45

## Reefing / Cunningham Hooks

Formed Stainless Steel with high strength welded eyes and long stems for secure insertion into sail grommet.

Item	Description	Up To	Rod Boat Size	Eye Dia	L Dia	W	Weight
76-45	Small Reefing/ Cunningham Hook	30' (9.1m)	1/4" (6mm)	7/16" (11mm)	2-5/8" (67mm)	1-13/16" (46mm)	2 oz. (58g)
76-46	Large Reefing/ Cunningham Hook	45' (13.7m)	5/16" (8mm)	5/8" (16mm)	3-7/8" (98mm)	2-1/2" (64mm)	3 oz. (85g)



76-46

## Universal Reefing Hooks

Formed from high quality Stainless Steel.

Item	Jaw Opening	Tack Pin Diameter	Gooseneck Pin Diameter	Depth Below Track Pin	Weight
54-21	3/4" (19mm)	3/8" (10mm)	3/8" (10mm)	7/8" (22mm)	3.5 oz. (99g)
54-22	1" (25mm)	1/2" (13mm)	1/2" (13mm)	1-1/16" (27mm)	6 oz. (170g)



54-21

## Masthead GPS/VHF Antenna Brackets

Our brackets accept most GPS or VHF antennas with 1" (26mm) x 14 thread. Convenient slot in the side of each unit allows antennas to be mounted without feeding the entire cable through base.

Item	Description	Fasteners	Weight
99-84	Flat Antenna mount	(5) #10 RH (5mm)	5.5 oz. (156g)
99-85	90° Antenna mount	(3) #10 RH (5mm)	8 oz. (227g)

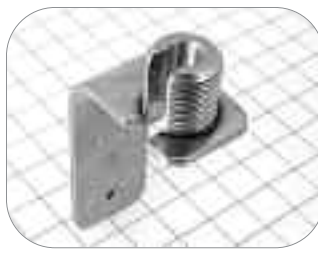

99-85



99-84

# Rigging Accessories

## Eye Jaw Toggles

Made of high quality Stainless Steel, these high fatigue fittings are designed for use with corresponding pin sizes of swage or mechanical type marine eyes commonly used on 1x19 stainless wire. Extra deep strap designed to allow end-to-end assembly to Double Jaw Toggles.



93-68

Item	Pin Dia.	Max. Wire	C/C	Strap W At Pin	Strap W At Top	Weight
93-64	1/4" (6mm)	1/8" (3mm)	1-1/16" (27mm)	5/8" (16mm)	7/32" (5mm)	.5 oz. (14g)
93-65	5/16" (8mm)	5/32" (4mm)	1-5/16" (33mm)	3/4" (19mm)	9/32" (7mm)	1.1oz. (31g)
93-66	3/8" (10mm)	3/16" (5mm)	1-9/16" (40mm)	1" (25mm)	11/32" (9mm)	2.0 oz. (57g)
93-67	1/2" (13mm)	5/16" (7mm)	2-3/32" (53mm)	1-1/4" (32mm)	15/32" (12mm)	4.3 oz. (122g)
93-68	5/8" (16mm)	3/8" (10mm)	2-5/8" (67mm)	1-1/2" (38mm)	19/32" (15mm)	9.4 oz. (266g)
93-69	3/4" (19mm)	7/16" (11mm)	3-3/16" (8mm)	1-5/8" (41mm)	23/32" (18mm)	15.7 oz. (445g)
93-70	7/8" (22mm)	1/2" (13mm)	3-3/8" (86mm)	1-15/16" (49mm)	7/8" (22mm)	1lb. 10.1 oz. (750g)



**SCHAEFER**  
LEGENDARY STRENGTH

## Double Jaw Toggles

Similar to our Eye Jaw design, Double Jaw Toggles are used with the same pin sizes as marine eyes and mechanical end fittings on 1 x 19 stainless wire. These high quality stainless toggles permit proper "universal" motion in rigging applications to help reduce wire, rod and end fitting fatigue. Extra deep slot allows use in split masthead sheave boxes. Toggle may be inverted to accept weldment tabs for chainplates.



93-88

Item	Pin Dia.	Max. Wire	C/C	Strap W At Pin	Strap W At Top	Weight
93-84	1/4" (6mm)	1/8" (3mm)	1-1/16" (27mm)	5/8" (16mm)	1/4" (6mm)	1.0 oz. (28g)
93-85	5/16" (8mm)	5/32" (4mm)	1-1/4" (32mm)	3/4" (19mm)	5/16" (8mm)	1.6oz. (45g)
93-86	3/8" (10mm)	3/16" (5mm)	1-1/2" (38mm)	1" (25mm)	3/8" (10mm)	2.7 oz. (76g)
93-87	1/2" (13mm)	9/32" (7mm)	2" (51mm)	1-1/4" (32mm)	1/2" (13mm)	5.8 oz. (64g)
93-88	5/8" (16mm)	3/8" (10mm)	2-1/2" (64mm)	1-1/2" (38mm)	5/8" (16mm)	11.8 oz. (334g)
93-89	3/4" (19mm)	7/16" (11mm)	3" (76mm)	1-3/4" (44mm)	3/4" (19mm)	1lb. 4.7oz. (587g)
93-90*	7/8" (22mm)	1/2" (13mm)	3-3/18" (86mm)	1-15/16" (49mm)	7/8" (22mm)	2lb. 6.4oz. (1.19kg)

## Link Tangs

Made of High Quality Stainless Steel, Link Tangs are designed to be used with our Eye Jaw Toggles, or in conjunction with marine eyes or mechanical end fittings of the same pin size commonly used on 1 x 19 stainless wire. Sold in pairs with clevis and cotter pins included.



84-95

Item	Pin Dia.	Max. Wire	C/C	Strap W At Pin	Strap W At Top	Weight
84-93	3/8" (10mm)	3/16" (5mm)	5-15/16" (149mm)	1-7/16" (36mm)	1" (25mm)	5.6 oz. (159g)
84-94	1/2" (13mm)	9/32" (7mm)	7-11/16" (192mm)	2-1/16" (52mm)	1-1/4" (32mm)	12.9 oz. (366g)
84-95	5/8" (16mm)	3/8" (10mm)	9-5/16" (233mm)	2-7/16" (61mm)	1-1/2" (38mm)	1lb. 9.3 oz. (717g)

Schaefer's Eye Jaw Toggles, Double Jaw toggles and Chainplates are designed to rated approximate breaking strengths of 1 x 19 Stainless Steel wire. Our recommendation, as well as that of most 1 x 19 wire manufacturers, is that safe working loads not exceed 33% of wire breaking strengths.

# Rigging Accessories

Item	Length	Width
85-13	3" (76mm)	1/2" (13mm)
85-14	4" (102mm)	1/2" (13mm)
85-15	5" (127mm)	1/2" (13mm)
85-16	6" (152mm)	1/2" (13mm)
85-18	8" (203mm)	1/2" (13mm)
85-20	10" (254mm)	1/2" (13mm)
85-22	12" (305mm)	1/2" (13mm)
85-23	3" (76mm)	3/4" (19mm)
85-24	4" (102mm)	3/4" (19mm)
85-25	5" (127mm)	3/4" (19mm)
85-26	6" (152mm)	3/4" (19mm)
85-27	7" (178mm)	3/4" (19mm)
85-28	8" (203mm)	3/4" (19mm)
85-29	9" (229mm)	3/4" (19mm)
85-30	10" (254mm)	3/4" (19mm)
85-32	12" (305mm)	3/4" (19mm)
85-01	4" (102mm)	1" (25mm)
85-02	6" (152mm)	1" (25mm)
85-03	8" (203mm)	1" (25mm)

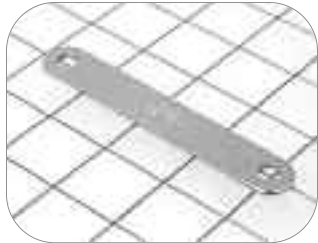

85-13

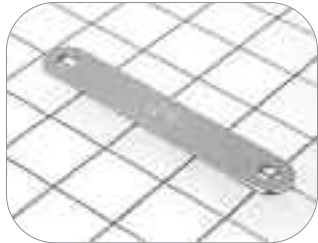

85-23

## Strap Tangs

Constructed of High Quality Stainless Steel. Available in a wide variety of widths, thicknesses and configurations. Each is radius chopped, hole punched, tumbled and polished.

1/2" (13mm) and 3/4" (19mm) wide tangs are 1/16" (1.5mm) thick with 3/16" (5mm) dia. Holes at each end. 1" (25mm) wide tangs are 3/32" (2mm) thick with 1/4" (6mm) dia. Holes at each end.

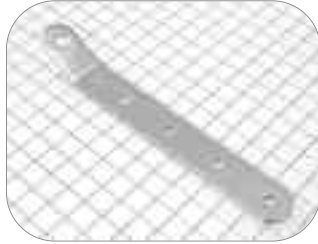

84-78

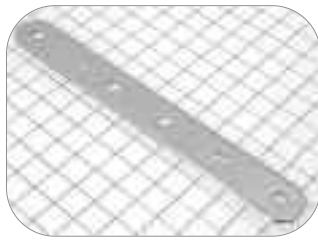

84-88



84-54

## Chainplates

Made from High Quality Stainless Steel tumbled and polished to a high luster finish.



Item Straight	Item Bent	Chainplate Cover*	Pin Hole	Max Wire	Fastener Holes	L	W	T	Weight
84-86	84-76	84-06**	1/4" (6mm)	1/8" (3mm)	(4) 1/4" (6mm)	8" (203mm)	1" (25mm)	3/32" (2mm)	3 oz. (85g)
84-87	84-77	84-69	5/16" (8mm)	5/32" (4mm)	(4) 1/4" (6mm)	9" (229mm)	1" (25mm)	1/8" (3mm)	4.6 oz. (130g)
84-88	84-78	84-54	3/8" (10mm)	3/16" (5mm)	(4) 3/8" (10mm)	10" (254mm)	1-1/4" (31mm)	1/8" (3mm)	6.6 oz. (187g)
84-89	---	---	7/16" (12mm)	7/32" (6mm)	(5) 3/8" (10mm)	12" (305mm)	1-1/4" (31mm)	3/16" (4mm)	10 oz. (283g)
84-90	84-80	84-56	1/2" (13mm)	9/32" (7mm)	(5) 1/2" (13mm)	14" (356mm)	1-1/2" (38mm)	1/4" (6mm)	1 lb. 5 oz. (595g)
84-91	84-81	84-57	5/8" (16mm)	3/8" (8mm)	(5) 1/2" (13mm)	16" (406mm)	1-1/2" (38mm)	3/8" (8mm)	2 lbs. 8 oz. (1.13kg)

\* All chainplate covers weigh 1 oz. (28g)  
\*\* 84-06 has two mounting holes

Call 508-995-9511 for Customer Service



# Rigging Accessories



84-99

## Triangle Plates

Manufactured from High Quality Stainless Steel, Triangle Plates are designed to be used with corresponding pin size of swage or mechanical type marine eyes commonly used with 1x19 stainless wire. Ideal for use with split backstays or triadic stays on ketch rig boats. Sold in pairs with (3) three clevis and cotter pins included.

Item	Upper Pin Dia.	Lower Pin Dia.	Upper Max Wire	Lower Max Wire	Overall Width	Weight
84-44	1/4" (6mm)	1/4" (6mm)	1/8" (3mm)	1/8" (3mm)	2-1/4" (57mm)	2.6 oz. (74g)
84-45	5/16" (8mm)	5/16" (8mm)	5/32" (4mm)	5/32" (4mm)	2-3/4" (70mm)	4.6 oz. (130g)
84-97*	3/8" (10mm)	5/16" (8mm)	3/16" (5mm)	5/32" (4mm)	2-3/4" (70mm)	5.0 oz. (142g)
84-46	3/8" (10mm)	3/8" (10mm)	3/16" (5mm)	3/16" (5mm)	2-3/4" (70mm)	5.9 oz. (167g)
84-98*	1/2" (13mm)	3/8" (10mm)	9/32" (7mm)	3/16" (5mm)	3-3/8" (86mm)	10.1 oz. (286g)
84-47	1/2" (13mm)	1/2" (13mm)	9/32" (7mm)	9/32" (7mm)	3-3/8" (86mm)	10.9 oz. (309g)
84-99*	5/8" (16mm)	1/2" (13mm)	3/8" (10mm)	9/32" (7mm)	3-15/16" (100mm)	1 lb. 5 oz. (595g)
84-48	5/8" (16mm)	5/8" (16mm)	3/8" (10mm)	3/8" (10mm)	3-15/16" (100mm)	1 lb. 5.7 oz. (615g)

\*Highlighted Triangle plates have stepped down pin diameters for typical backstay applications.



If you are in doubt as to the suitability of your selection please contact Schaefer for assistance.



94-21

## Round Utility Rings

Perfect for Adjustable Backstay configurations and many other applications. Schaefer's High-Strength Stainless Steel Rings are welded from Stainless Steel Rod then polished and buffed to a mirror smooth surface.

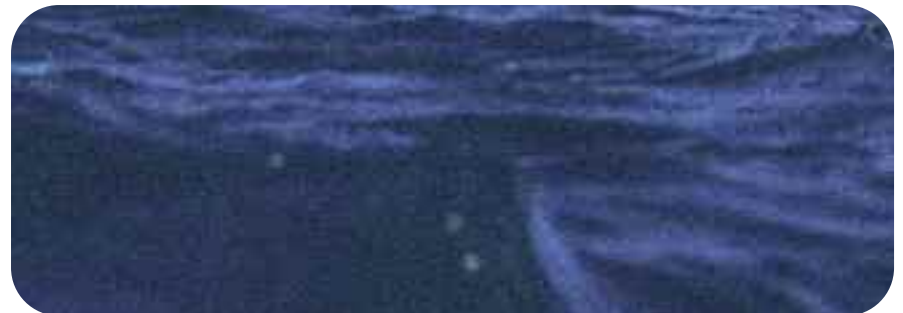

Item	Stock Dia.	Inside Dia.	SWL	Weight
94-01	3/16" (5mm)	3/4" (19mm)	1500 lbs. (680kg)	.75 oz. (21g)
94-02	3/16" (5mm)	1" (25mm)	1500 lbs. (680kg)	.75 oz. (21g)
94-03	3/16" (5mm)	1-1/4" (32mm)	1500 lbs. (680kg)	1 oz. (28g)
94-21	1/4" (6mm)	1" (25mm)	2000 lbs. (900kg)	1.5 oz. (43g)
94-22	1/4" (6mm)	1-1/2" (38mm)	2000 lbs. (900kg)	1.75 oz. (50g)
94-23	1/4" (6mm)	2" (51mm)	2000 lbs. (900kg)	2 oz. (57g)
94-41	3/8" (10mm)	2-1/2" (64mm)	2500 lbs. (1135kg)	4.5 oz. (128g)
94-42	3/8" (10mm)	3-1/4" (83mm)	2500 lbs. (1135kg)	6 oz. (170g)



# Rigging Accessories

## Stainless Bails

Perfect for attaching blocks to your boom or boom vang to your spars. Schaefer's bails are formed from High Quality Stainless Steel tumbled and polished to a high luster finish. Choose from our stamped versions for dinghys and small daysailors or from our exceptionally strong Heavy Duty Forged Bails for larger cruisers or racers.



Item	Descrip.	Rod Dia	Width	Depth	Fastener Size	Weight
90-04	Stamped Bail	---	1-5/8" (41mm)	1-3/4" (44mm)	1/4" (6mm)	.75 oz. (21g)
90-01	Stamped Bail	---	1-3/4" (44mm)	3-1/2" (89mm)	1/4" (6mm)	.75 oz. (21g)
90-27	Forged Bail/ Round	1/4" (6mm)	2-1/4" (57mm)	3" (76mm)	1/4" (6mm)	2 oz. (57g)
90-28	Forged Bail/ Round	1/4" (6mm)	2-3/4" (70mm)	3-1/2" (89mm)	1/4" (6mm)	2 oz. (57g)
90-10	Forged Bail/ Round	3/8" (10mm)	2-1/4" (57mm)	3-3/4" (95mm)	3/8" (10mm)	5 oz. (142g)
90-09	Forged Bail/ Round	3/8" (10mm)	2-3/4" (70mm)	3-3/4" (95mm)	3/8" (10mm)	5 oz. (142g)
90-08	Forged Bail/ Round	3/8" (10mm)	3-3/4" (95mm)	4" (102mm)	3/8" (10mm)	6 oz. (170g)
90-07	Forged Bail/ V	3/8" (10mm)	3" (76mm)	5" (127mm)	3/8" (10mm)	7 oz. (198g)
90-12	Forged Bail/ V	3/8" (10mm)	5-3/4" (146mm)	8-3/8" (213mm)	3/8" (10mm)	10 oz. (284g)

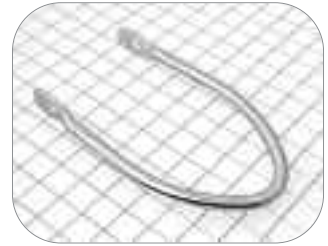

90-07



90-09



90-01



**Warning**  
 Warm water or tropical sailing conditions are harsh on all marine equipment and can rapidly speed material degradation. A very careful inspection on a regular basis is necessary to insure safety.



# Shackles



93-13

## Forged "D" Shackles

Schaefer's drop Forged "D" Shackles are made from type 316 Stainless Steel. Each shackle features a threaded pin with a drilled cross pin hole to accommodate safety wire.

**If you are in doubt as to the suitability of your selection please contact Schaefer for assistance.**



93-25

## Long "D" Shackles

Our Long "D" Shackles offer the same great features of our forged "D" shackles with extra-long usable lengths to access those hard to reach fittings on your boat.



93-63

## Twist Shackles

"Twist" shackle bodies are forged with a built-in twist that when mounted on bails or pad eyes, helps align the pin axis in relation to the matched block being used. Drop forged from type 316 Stainless Steel, each threaded pin has a cross hole for safety wire.



93-01

## Bow Shackles

Our drop forged "Bow" Shackles are "bowed" to offer an increased body width that provides a large surface contact area for spliced line and thimbles. These type 316 Stainless Steel shackles are all provided with a cross hole for safety wire.

Standard Pin	Pin Dia.	Depth.	Width	SWL	Weight
93-13	3/16" (5mm)	23/32" (18mm)	25/32" (19mm)	1240 lbs. (562kg)	0.5 oz. (14g)
93-12	1/4" (6mm)	29/32" (23mm)	1/2" (13mm)	1530 lbs. (694kg)	0.9 oz. (26g)
93-11	5/16" (8mm)	1-3/32" (28mm)	23/32" (18mm)	2480 lbs. (1125kg)	1.8 oz. (51g)
93-10	3/8" (10mm)	1-1/16" (27mm)	7/8" (22mm)	4000 lbs. (1814kg)	3.1 oz. (88g)
93-18	3/8" (10mm)	1-9/32" (33mm)	1/16" (27mm)	4000 lbs. (1814kg)	3.6 oz. (102g)
93-14	3/8" (10mm)	1-7/16" (37mm)	3/4" (19mm)	4000 lbs. (1814kg)	3.3 oz. (94g)
93-19	7/16" (11mm)	1-23/32" (44mm)	1-11/16" (42mm)	4960 lbs. (2250kg)	5.4 oz. (153g)
93-15	1/2" (13mm)	2-3/32" (53mm)	1" (25mm)	6200 lbs. (2812kg)	8.4 oz. (238g)
93-23	5/8" (16mm)	2-3/16" (56mm)	1-5/32" (29mm)	8270 lbs. (3750kg)	13.3 oz. (377g)

Standard Pin	Pin Dia.	Depth.	Width	SWL	Weight
93-25	3/16" (5mm)	1-1/16" (27mm)	7/16" (11mm)	1000 lbs. (455kg)	.6 oz. (17g)
93-26	1/4" (6mm)	1-5/8" (41mm)	1/2" (13mm)	1320 lbs. (600kg)	1.2 oz. (34g)
93-27	5/16" (8mm)	1-15/16" (49mm)	11/16" (17mm)	2000 lbs. (916kg)	2.4 oz. (68g)

Standard Pin	Pin Dia.	Depth.	Width	SWL	Weight
93-63	3/16" (5mm)	11/16" (17mm)	3/8" (10mm)	1000 lbs. (455kg)	.5 oz. (14g)
93-62	1/4" (6mm)	13/16" (21mm)	1/2" (13mm)	1320 lbs. (600kg)	.9 oz. (26g)
93-61	5/16" (8mm)	1-1/16" (27mm)	5/8" (16mm)	2000 lbs. (910kg)	2.0 oz. (57g)
93-57	3/8" (10mm)	1-1/8" (29mm)	3/4" (19mm)	3100 lbs. (1410kg)	3.4 oz. (96g)

Standard Pin	Pin Dia.	Depth.	Width	SWL	Weight
93-01	3/16" (5mm)	29/32" (23mm)	7/16" (11mm)	1000 lbs. (455kg)	.5 oz. (14g)
93-03	1/4" (6mm)	1-3/32" (28mm)	1/2" (13mm)	1320 lbs. (600kg)	1.1 oz. (31g)
93-04	5/16" (8mm)	1-11/32" (34mm)	23/32" (18mm)	2000 lbs. (910kg)	2.1 oz. (60g)
93-02	3/8" (10mm)	1-9/16" (40mm)	3/4" (19mm)	3100 lbs. (1410kg)	3.4 oz. (96g)
93-05	7/16" (11mm)	1-27/32" (47mm)	29/32" (23mm)	3970 lbs. (1800kg)	5.9 oz. (167g)
93-06	1/2" (13mm)	2-3/16" (55mm)	1" (25mm)	4960 lbs. (2250kg)	9.0 oz. (255g)

# Shackles

## Stamped "D" Shackles

Stamped from High Quality Stainless Steel, these lightweight shackles are provided with a stainless clevis pin and cotter ring.

Standard Pin	Pin Dia	Depth.	Width	SWL	Weight
93-32	3/16" (5mm)	39/64" (15mm)	27/64" (11mm)	1,000 lbs. (450kg)	.3 oz. (9g)
93-31	3/16" (5mm)	5/8" (16mm)	7/16" (11mm)	1,250 lbs. (510kg)	.2 oz. (6g)
93-33	1/4" (6mm)	13/16" (21mm)	1/2" (13mm)	1,750 lbs. (795kg)	.6 oz. (17g)
93-21	1/4" (6mm)	1" (25mm)	11/16" (17mm)	1,750 lbs. (795kg)	1.1 oz. (31g)
93-51	9/64" (3.5mm)	5/8" (16mm)	9/32" (7mm)	250 lbs. (115kg)	.2 oz. (9g)



93-21

## Stamped Halyard Shackles

All Schaefer Stamped Halyard Shackles feature a captive design to prevent accidental pin loss. Smaller versions are spring loaded to provide a firm fit to keyway and indents to insure positive engagement.

Item	Description	Max Line Wire Dia.	Pin A	L	W	SWL	Weight
93-41	Stamped / Non Retainer Shackle / Spring Loaded	3/32" wire (2mm)	1/4" (6mm)	1-5/8" (41mm)	9/16" (14mm)	1000 lbs. (450kg)	1.5 oz. (43g)
93-42	Stamped / Long Retainer Spring Loaded	5/16" line (8mm)	1/4" (6mm)	1-3/16" (30mm)	9/16" (14mm)	1550 lbs. (705kg)	1.5 oz. (43g)
93-43	Stamped / Short Retainer Shackle / Spring Loaded	5/16" line (8mm)	1/4" (6mm)	9/16" (14mm)	9/16" (14mm)	1550 lbs. (705kg)	1 oz. (28g)
93-45	Stamped / Heavy-Duty Shackle / Twist Pin	1/2" line (13mm)	5/16" (8mm)	1-1/8" (29mm)	3/4" (19mm)	2500 lbs. (1135kg)	1 oz. (28g)



93-45



93-41



93-42



93-43



Item	Description	Max Line Wire Dia.	Pin A	Pin B	L	W	SWL	Weight
93-80	Investment Cast Wire Shackle	3/16" wire (5mm)	7/16" (11mm)	3/8" (10mm)	1-3/16" (30mm)	3/4" (19mm)	4500 lbs. (2045kg)	6 oz. (170g)
93-81	Investment Cast Wire Shackle	1/4" wire (6mm)	5/8" (16mm)	1/2" (13mm)	2-5/16" (59mm)	1" (25mm)	7500 lbs. (3400kg)	11 oz. (312g)



93-81

## Investment Cast Halyard Shackles

Double threaded shackle pin design allows removal of the headboard with only one unthreading, yet prevents the pin from being accidentally withdrawn. Unique pin recess hold is cast into one of the jaws, allowing full headboard clearance when the pin is unthreaded. A second unthreading allows you to remove the pin entirely.

Item	Description	Max Line Wire Dia.	Pin A	L	W	SWL	Weight
93-75	Investment Cast Line Shackle	1/2" line (13mm)	7/16" (11mm)	1-3/16" (30mm)	3/4" (19mm)	4500 lbs. (2045kg)	5.75 oz. (163g)
93-76	Investment Cast Line Shackle	3/4" line (19mm)	5/8" (16mm)	1-5/16" (41mm)	1" (25mm)	7500 lbs. (3400kg)	11 oz. (312g)



93-75



# Snap Shackles



## Snap Shackles

Schaefer's Snap Shackles are designed for maximum strength with smooth, jam-free operation.

Our enlarged throat and hinge area handles shear and twisting movements effectively. The smooth shackle arc prevents jamming against pad eyes or sail grommets to permit easy attachment and release.

Sure-release action results from a positive stop plunger pin with shear-proof pulling ring and accurately aligned deep slot hinged design.

Snap Shackles are designed to allow quick release of loads when pin is pulled. While this is a convenience for many applications involving spinnakers and sheets, there is a danger that misuse or misapplication could result in damage to equipment or personal injury.



45-10



45-01

Item	Description	Ball/Pin Dia.	Jaw Length	Jaw Width	L	W	SWL	Weight
45-10	Snap Shackle/Line Bail	1" (25mm)	1-1/4" (32mm)	1-9/32" (32mm)	4-3/8" (111mm)	2-1/8" (54mm)	5000 lbs. (2270kg)	9 oz. (225g)
45-05	Snap Shackle/Line Bail	3/4" (19mm)	1-3/16" (30mm)	15/16" (24mm)	3-17/32" (90mm)	1-5/8" (41mm)	3750 lbs. (1700kg)	4 oz. (113g)
45-01	Snap Shackle/Line Bail	19/32" (15mm)	15/16" (24mm)	3/4" (19mm)	2-25/32" (70mm)	1-9/32" (32mm)	2250 lbs. (1020kg)	2 oz. (57g)



45-30



45-21

Item	Description	Bail/Pin Dia.	Clip Length	Clip Width	Jaw Width	Jaw Length	L	W	SWL	Weight
45-30	Tack Shackle/Clevis Pin	3/8" (10mm)	27/32" (21mm)	3/4" (19mm)	1-1/4" (32mm)	1-9/32" (32mm)	4-21/32" (119mm)	2-1/8" (54mm)	5000 lbs. (2270kg)	10oz. (284g)
45-25	Tack Shackle/Clevis Pin	5/16" (8mm)	17/32" (13mm)	9/16" (14mm)	15/16" (24mm)	1-3/16" (30mm)	3-21/32" (93mm)	1-3/4" (44mm)	3750 lbs. (1700kg)	4oz. (113g)
45-21	Tack Shackle Clevis Pin	1/4" (6mm)	19/32" (15mm)	1/4" (6mm)	15/16" (24mm)	3/4" (19mm)	3-1/32" (77mm)	1-9/32" (32mm)	2250 lbs. (1020kg)	2oz. (57g)



99-23

## Leather Leashes

Schaefer's Leather Leashes come in packages of three. Perfect for providing an easy release on any Snap Shackle.



45-50-R

## Shackle Guards

Schaefer's Shackle Guards prevent your snap shackles from jamming in spinnaker pole ends. Made of UV treated urethane for exceptional impact, UV and corrosion resistance. Guards have four 1/8" (3mm) holes for lashing to sheets or guys.

Item	Descrip.	Outside Dia.	Inside Dia.	Thickness	Weight
45-50-R	Shackle Guard Red	3" (76mm)	1/2" (13mm)	5/8" (16mm)	4 oz. (113g)
45-50-G	Shackle Guard Green	3" (76mm)	1/2" (13mm)	5/8" (16mm)	4 oz. (113g)

# Winch Handles



## Schaefer Forged Winch Handles

Schaefer offers three distinct styles of Winch Handles to suit your needs. Our 10" forged aluminum models use 6061 T6 Anodized Aluminum and come in either Standard or Ball Grip. Both offer a simple locking mechanism for security.

Our New 8" Carbon Fiber handle features a compressed carbon fiber construction that weighs just over 1/2 pound! This strong yet light handle will keep racers satisfied in the never ending search for weight savings.

Item	Description	Handle	Arm Length	Weight
WHL-10-S	Standard Grip Winch Handle Forged Aluminum	Delrin Standard	10.0" Standard (254 mm)	1.0 lb. (.45 kg)
WHL-10-D	Ball Grip Winch Handle Forged Aluminum	Delrin Ball Top	10.0" Standard (254 mm)	1.0 lb. (.45 kg)
WH-8	Standard Grip Carbon Fiber Winch Handle	Delrin Standard	8.0" (203mm)	.508 lbs (.228kg)

# Handi-Hanger

## Handi-Hanger

Handi Hangers are used in the cockpit or a stern pulpit to organize line, fenders, life rings and whatever else you can think of.

They allow for one handed release of the line and are neater and more versatile than any other line handling/stowing application. Flat mounts come in pairs and rail mounts are designed to fit 7/8" or 1" tubing or coated lifeline wire.

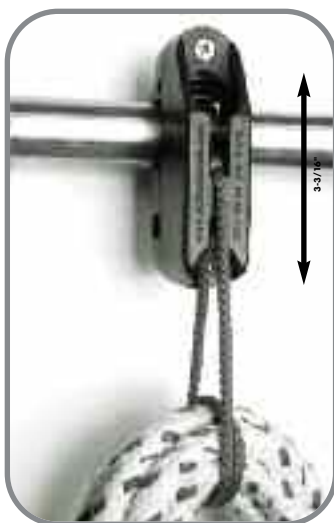

## Handi-Hangers

Item	Description	Safe Working Load
HHF	Handi-Hanger Flat Mount	20.0 lbs.
HHR	Handi-Hanger Rail Mount	20.0 lbs.

# Anchor-Hanger

## Anchor Hanger

Fits Danforth Style anchors 8-22 lbs. Simple clamp attachment to either bow or stern rail. Simply slide anchor stock into the port hanger then insert the opposite end into the starboard latch for a secure fit.

Twist in body keeps alignment true when installed on curved bow rails. Made from 316 S.S., reinforced to prevent damage. Vinyl liner protects your 1" rails.



## Anchor-Hanger

Item	Description	Weight
AH-100	Anchor Hanger	13 oz. (369g)

# Rudder Hardware



## Dinghy / Keelboat Pintles & Gudgeons

Schaefer welded Stainless Steel Dinghy and Small Keel Boat Pintles come in two lengths allowing for easier rudder installation. Made from the highest quality Stainless Steel, built to handle the loads created by high performance boats.



80-12

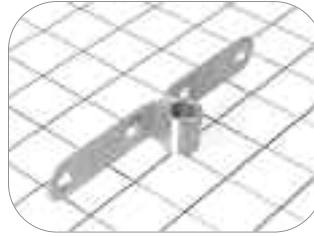

81-01

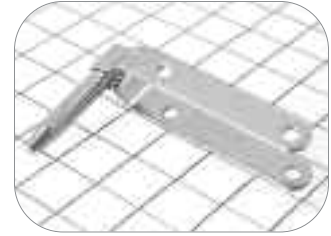

80-11

Item	Descrip.	Boat Size	Rudder Width	Pin Dia.	Pin Length	Strap Thick.	Strap Length	Strap Width	Fasteners	Weight
80-02	Dinghy / Upper Pintle	Up to 17' (5.2m)	1/2" (13mm)	5/16" (8mm)	1-1/4" (32mm)	1/16" (1mm)	3" (76mm)	1/2" (13mm)	(4) #10 RH (5mm)	7.5 oz. (50g)
80-01	Dinghy / Lower Pintle	Up to 17' (5.2m)	1/2" (13mm)	5/16" (8mm)	1-1/2" (38mm)	1/16" (1mm)	3" (76mm)	1/2" (13mm)	(4) #10 RH (5mm)	2 oz. (57g)
80-12	Dinghy / Upper Pintle	Up to 17' (5.2m)	3/4" (19mm)	5/16" (8mm)	1-1/4" (32mm)	1/16" (1mm)	3" (76mm)	1/2" (13mm)	(4) #10 RH (5mm)	1.75 oz. (50g)
80-11	Dinghy / Lower Pintle	Up to 17' (5.2m)	3/4" (19mm)	5/16" (8mm)	1-1/2" (38mm)	1/16" (1mm)	3" (76mm)	1/2" (13mm)	(4) #10 RH (5mm)	2 oz. (576g)
81-01	Dinghy / Gudgeon Pintle	Up to 17' (5.2m)	---	---	---	1/16" (1mm)	3-1/2" (86mm)	1/2" (13mm)	(2) #10 RH (5mm)	1.25 oz. (35g)
82-01	Dinghy / Spring Stop	Up to 17' (5.2m)	---	---	---	1/16" (1mm)	4" (102mm)	1/2" (13mm)	(2) #10 RH (5mm)	.5 oz. (14g)



80-56



81-41

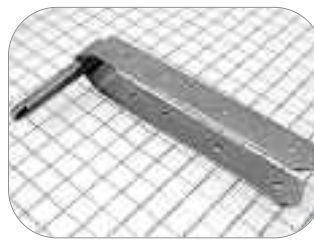

80-55



81-43



80-45

Item	Descrip.	Boat Size	Rudder Width	Pin Dia.	Pin Length	Strap Thick.	Strap Length	Strap Width	Fasteners	Weight
80-46	Keel Boat / Upper Pintle	Up to 20' (6.1m)	1" (25mm)	1/2" (13mm)	1-3/4" (44mm)	5/64" (2mm)	3-3/8" (86mm)	1" (25mm)	(2) #10 RH (5mm)	5.25 oz. (149g)
80-45	Keel Boat / Lower Pintle	Up to 20' (6.1m)	1" (25mm)	1/2" (13mm)	2-3/4" (70mm)	5/64" (2mm)	7" (178mm)	1" (25mm)	(4) #10 RH (5mm)	9 oz. (255g)
80-56	Keel Boat / Upper Pintle	Up to 20' (6.1m)	1-1/2" (38mm)	1/2" (13mm)	1-3/4" (44mm)	1/8" (3mm)	3-3/8" (86mm)	1" (25mm)	(2) #10 RH (5mm)	7 oz. (198g)
80-55	Keel Boat / Lower Pintle	Up to 20' (6.1m)	1-1/2" (38mm)	1/2" (13mm)	2-3/4" (70mm)	1/8" (3mm)	7" (178mm)	1" (25mm)	(4) #10 RH (5mm)	12 oz. (340g)
81-43*	Keel Boat / Gudgeon	Up to 20' (6.1m)	---	1/2" (13mm)	---	1/8" (3mm)	3-3/4" (95mm)	1" (25mm)	(4) 1/4" RH (5mm)	3 oz. (85g)
81-41*	Keel Boat / Gudgeon	Up to 20' (6.1m)	---	1/2" (13mm)	---	1/8" (3mm)	3 9/16" (90mm)	7/8" (22mm)	(2) 1/4" FH (5mm)	3.25 oz. (92g)

\* Accepts 1/2" (13mm) pins Bushing for 81-41 is #25-047



80-46

# Rudder Hardware



## J/24 Style Pintles & Gudgeons

Our Medium-Duty Pintles and Gudgeon components are most familiar as "J/24 type" with separate pins and welded pintle straps contained between an upper and lower gudgeon strap. This high strength, easily removed design is excellent for trailerable boats.



81-47



81-50



85-44



81-48



81-49

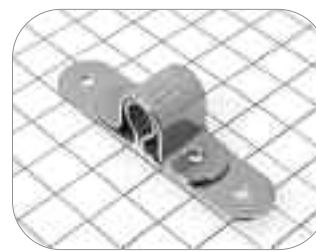

81-46

Item	Descrip.	Boat Size	Rudder Width	Pin Dia.	Pin Length	Strap Thick.	Strap Length	Strap Width	Fasteners	Weight
81-47	J/24 Upper Gudgeon	Up to 25' (7.6m)	1/2" (38mm)	1/2" (13mm)	---	3/16" (5mm)	3-5/16" (84mm)	1" (25mm)	(4) 1/4" RH (6mm)	10 oz. (284g)
81-48	J/24 Lower Gudgeon	Up to 25' (7.6m)	1-1/2" (38mm)	1/2" (13mm)	---	3/16" (5mm)	6-9/16" (167mm)	1" (25mm)	(8) 1/4" RH (6mm)	1 lb. (454g)
81-46	J/24 Strap	Up to 25' (7.6m)	---	1/2" (13mm)	---	1/8" (3mm)	4-1/4" (108mm)	1" (25mm)	(4) 1/4" RH (6mm)	2 oz. (57g)
81-49	J/24 Pin w/Clip	Up to 25' (7.6m)	---	1/2" (13mm)	3-7/8" (98mm)	---	---	---	---	2 oz. (57g)
81-50*	J/24 Assembly	Up to 25' (7.6m)	---	1/2" (13mm)	3-7/8" (98mm)	1/8" (3mm)	4-1/4" (108mm)	1" (25mm)	(8) 1/4" RH (6mm)	8 oz. (227g)
85-44	J/24 Type Tiller Straps	Up to 25' (7.6m)	---	3/8" (10mm)	---	3/16" (5mm)	12" (305mm)	1-1/2" (38mm)	(3) 1/4" RH (6mm)	1 lb. (454g)

\* 81-50 includes (2) 81-46 (1) 81-49, \*\* Accepts 1/2" (13mm) pins

\*\* 51-083 hitch pin for 81-49

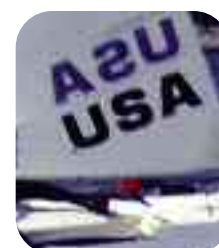

## Sheaves

Schaefer Blocks rely on a variety of sheave designs, materials and scorings. We do not recommend the replacement of Schaefer sheaves in the field. We suggest the return of Schaefer Blocks to our factory for inspection and/or replacement of worn or UV affected sheaves. Schaefer sheaves are designed to be compatible with Schaefer products, and are not intended for use in other manufacturers blocks. There is a risk of incompatibility or failure when using Schaefer sheaves in blocks manufactured by anyone other than Schaefer Marine.

## Delrin™ Ball Bearing

Delrin™ Sheaves with Delrin™ Ball Bearing are used in line applications to reduce friction. To provide the maximum load bearing capability, we designed our Delrin™ ball bearing sheaves and inner races with curved surfaces to match the ball races. The resulting sheave has a much higher safe working load than other manufacturers'.

## Delrin™

Delrin™ Sheaves are injected molded with UV inhibitors and monitored molding cycles leading to a strong, UV resistant product. These sheaves offer durable, lasting service for all line application.

## Aluminum Universal Circuit Sheaves (UC)

These extremely low friction ball bearing sheaves accommodate both line and wire. High strength self-contained Delrin™ bearing package, and Nomex™/Teflon™ self-lubricating bushing is used in all "UC" sheaves. The combined benefits of the design mean easier turning under the heaviest loads.

## Aluminum

This configuration accommodates both line and wire, providing a chafe-free surface for line while giving full support to wire to prevent flattening. Hardcoat Anodized 6061-T6 Aluminum offers superior strength and corrosion resistance.

Item	Material	Max Line	Max Wire	Outside Dia.	Inside Diameter	Width
62-020-01	Delrin™	1/4" (6mm)	---	3/4" (19mm)	1/4" (6mm)	11/32" (9mm)
62-020-02	Delrin™	5/16" (8mm)	---	1-1/16" (27mm)	5/16" (8mm)	7/16" (11mm)
62-214	Delrin™ (BB)	5/16" (8mm)	---	1-1/16" (27mm)	3/16" (5mm)	1/2" (13mm)
62-220	Delrin™	1/2" (13mm)	---	1-1/16" (27mm)	3/8" (10mm)	5/8" (16mm)
62-030-02	Delrin™	1/2" (13mm)	---	1-7/16" (37mm)	3/8" (10mm)	5/8" (16mm)
62-030-04	Delrin™ Black	1/2" (13mm)	---	1-7/16" (37mm)	3/8" (10mm)	5/8" (16mm)
62-031	Delrin™	3/8" (10mm)	---	1-7/16" (37mm)	5/16" (8mm)	17/32" (13mm)
62-095-BW	Alum.	---	5/32" (4mm)	1-7/16" (37mm)	5/16" (8mm)	9/32" (7mm)
62-150-02A	Delrin™ (BB)	1/2" (13mm)	---	1-7/16" (37mm)	3/16" (5mm)	5/8" (16mm)
62-218-BW	Alum.	1/2" (13mm)	3/16" (5mm)	1-7/16" (37mm)	3/8" (10mm)	19/32" (15mm)
62-219	Delrin™	1/2" (13mm)	---	1-3/4" (44mm)	3/8" (10mm)	5/8" (16mm)
62-043-01	Delrin™	5/8" (16mm)	---	1-7/8" (48mm)	7/16" (11mm)	13/16" (21mm)
62-043-01B	Delrin™	5/8" (16mm)	---	1-7/8" (48mm)	7/16" (11mm)	13/16" (21mm)
62-043-02	Delrin™ Black	5/8" (16mm)	---	1-7/8" (48mm)	7/16" (11mm)	13/16" (21mm)
62-043-02B	Delrin™ Black	5/8" (16mm)	---	1-7/8" (48mm)	7/16" (11mm)	13/16" (21mm)
62-243	Alum. (U.C.)	5/8" (16mm)	1/8" (3mm)	1-7/8" (48mm)	1/4" (6mm)	13/16" (21mm)
62-018	Delrin™	1/2" (13mm)	---	2" (51mm)	3/8" (10mm)	5/8" (16mm)
62-018-01	Delrin™ Black	1/2" (13mm)	---	2" (51mm)	3/8" (10mm)	5/8" (16mm)
62-023-15BW	Alum.	1/2" (13mm)	3/16" (5mm)	2" (51mm)	3/8" (10mm)	5/8" (16mm)
62-023-15CW	Alum.	1/2" (13mm)	3/16" (5mm)	2" (51mm)	1/2" (13mm)	5/8" (16mm)
62-051	Delrin™	1/2" (13mm)	---	2" (51mm)	1/2" (13mm)	5/8" (16mm)
62-051-01	Delrin™ Black	1/2" (13mm)	---	2" (51mm)	1/2" (13mm)	5/8" (16mm)
62-152-02A	Delrin™ (BB)	1/2" (13mm)	---	2" (51mm)	3/16" (5mm)	5/8" (16mm)
62-030-01	Delrin™	1/2" (13mm)	---	2-1/4" (57mm)	3/8" (10mm)	5/8" (16mm)
62-030-03	Delrin™ Black	1/2" (13mm)	---	2-1/4" (57mm)	3/8" (10mm)	5/8" (16mm)
62-019	Delrin™	5/8" (16mm)	---	2-3/8" (60mm)	7/16" (11mm)	13/16" (21mm)
62-019-02	Delrin™ Black	5/8" (16mm)	---	2-3/8" (60mm)	7/16" (11mm)	13/16" (21mm)
62-019-02B	Delrin™ Black	5/8" (16mm)	---	2-3/8" (60mm)	7/16" (11mm)	13/16" (21mm)
62-019-03B	Delrin™ Black	5/8" (16mm)	---	2-3/8" (60mm)	1/2" (13mm)	13/16" (21mm)
62-053-B	Delrin™	5/8" (16mm)	---	2-3/8" (60mm)	7/16" (11mm)	13/16" (21mm)
62-054-BW	Alum.	5/8" (16mm)	3/16" (5mm)	2-3/8" (60mm)	7/16" (11mm)	3/4" (19mm)
62-065B	Delrin™	5/8" (16mm)	---	2-3/8" (60mm)	1/2" (13mm)	13/16" (21mm)
62-070-BW	Alum.	5/8" (16mm)	3/16" (5mm)	2-3/8" (60mm)	1/2" (13mm)	3/4" (19mm)
62-081-BW	Alum.	3/8" (10mm)	3/16" (5mm)	2-3/8" (60mm)	5/8" (16mm)	9/16" (14mm)
62-153-02A	Delrin™ (BB)	5/8" (16mm)	---	2-3/8" (60mm)	1/4" (6mm)	13/16" (21mm)
62-228-BW	Alum.	---	1/8" (3mm)	2-3/8" (60mm)	7/16" (11mm)	13/32" (10mm)
62-242	Alum. (U.C.)	5/8" (16mm)	---	2-3/8" (60mm)	1/4" (6mm)	13/16" (21mm)
62-244	Alum. (U.C.)	3/4" (19mm)	1/4" (3mm)	2-1/2" (64mm)	1/2" (13mm)	1-1/32" (26mm)
62-039-02BW	Plastic	3/4" (19mm)	---	3-1/4" (83mm)	5/8" (16mm)	3/4" (19mm)
62-229-BW	Alum.	---	3/16" (5mm)	3-1/4" (83mm)	5/8" (16mm)	17/32" (14mm)
62-241	Alum. (U.C.)	5/8" (16mm)	3/16" (5mm)	3-1/4" (83mm)	3/8" (10mm)	13/16" (21mm)
62-230-BW	Alum.	---	1/4" (6mm)	4" (102mm)	3/4" (19mm)	11/16" (18mm)
62-240	Alum. (U.C.)	3/4" (19mm)	1/4" (6mm)	4" (102mm)	1/2" (13mm)	1-1/32" (26mm)
62-247	Alum. (U.C.)	7/8" (22mm)	3/8" (10mm)	5-1/2" (140mm)	3/4" (19mm)	1-3/16" (30mm)

*Schaefer Furling and Reefing systems are legendary for their ability to perform under the most adverse conditions. All of our furlers use Torlon™ bearings in machined races to assure smooth operation. Trust Schaefer Furling to add a whole new dimension to your foretriangle.*

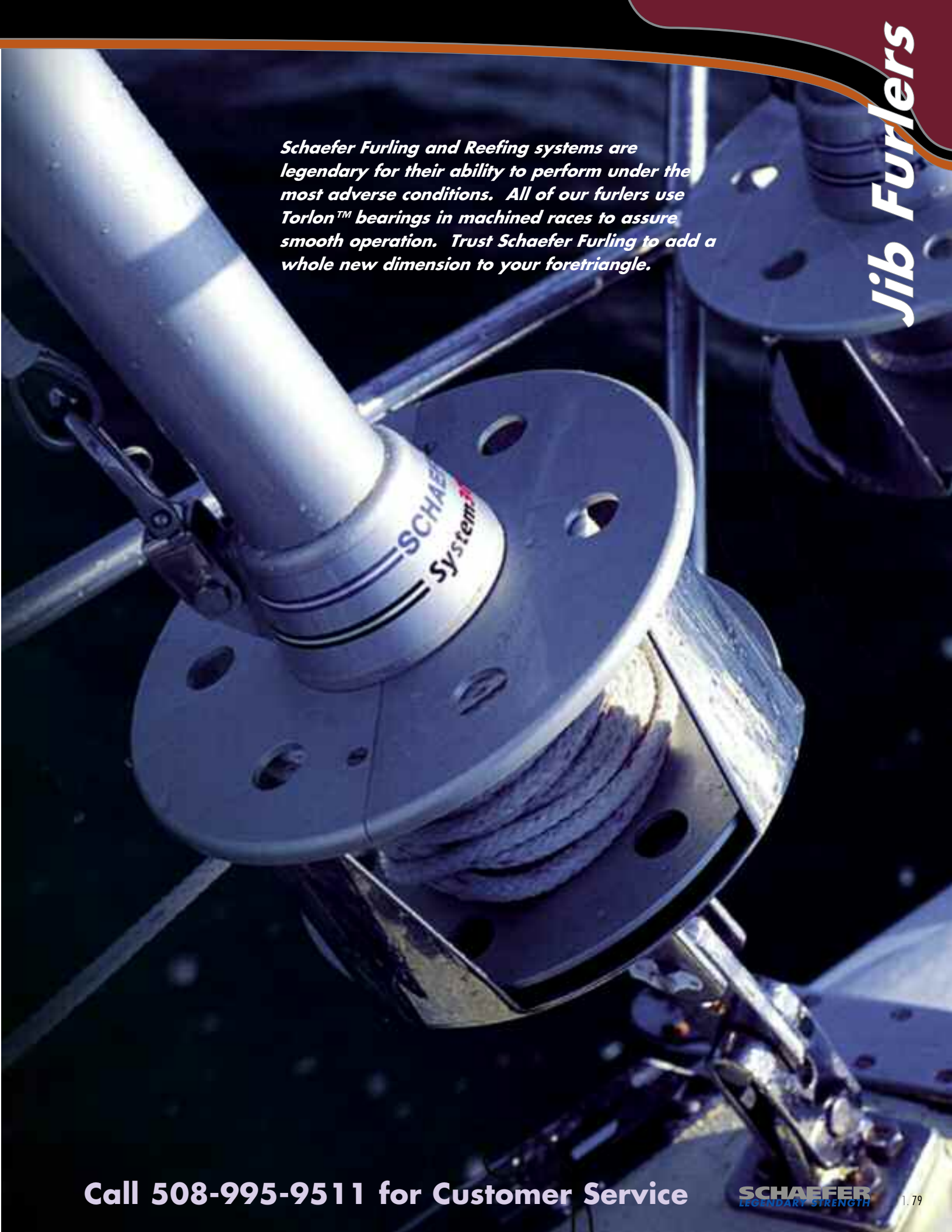

**Call 508-995-9511 for Customer Service**

**SCHAEFER**  
LEGENDARY STRENGTH



**Captive Fasteners**  
Fasteners are captive and set in heli-coils to prevent seizing.

**Removable Split Drum**  
System 1100, 2100, 3100, and 4100 allow easy conversion for racing.

**Investment Cast Stainless Drum Cage**  
Prevents damage to the drum from anchors.

**Open Drum Design**  
Allows for easy furling line inspection and includes a flushing hole for easy maintenance.

**Full Headstay Adjustment**  
Use of existing headstay and turnbuckle reduces expense and installation time and allows full adjustment.

**Large Diameter Drum**  
Provides greater mechanical advantage and additional control line capacity.

**Heavy-Duty Base Toggle / Link**  
Over-built to handle excessive side loads.

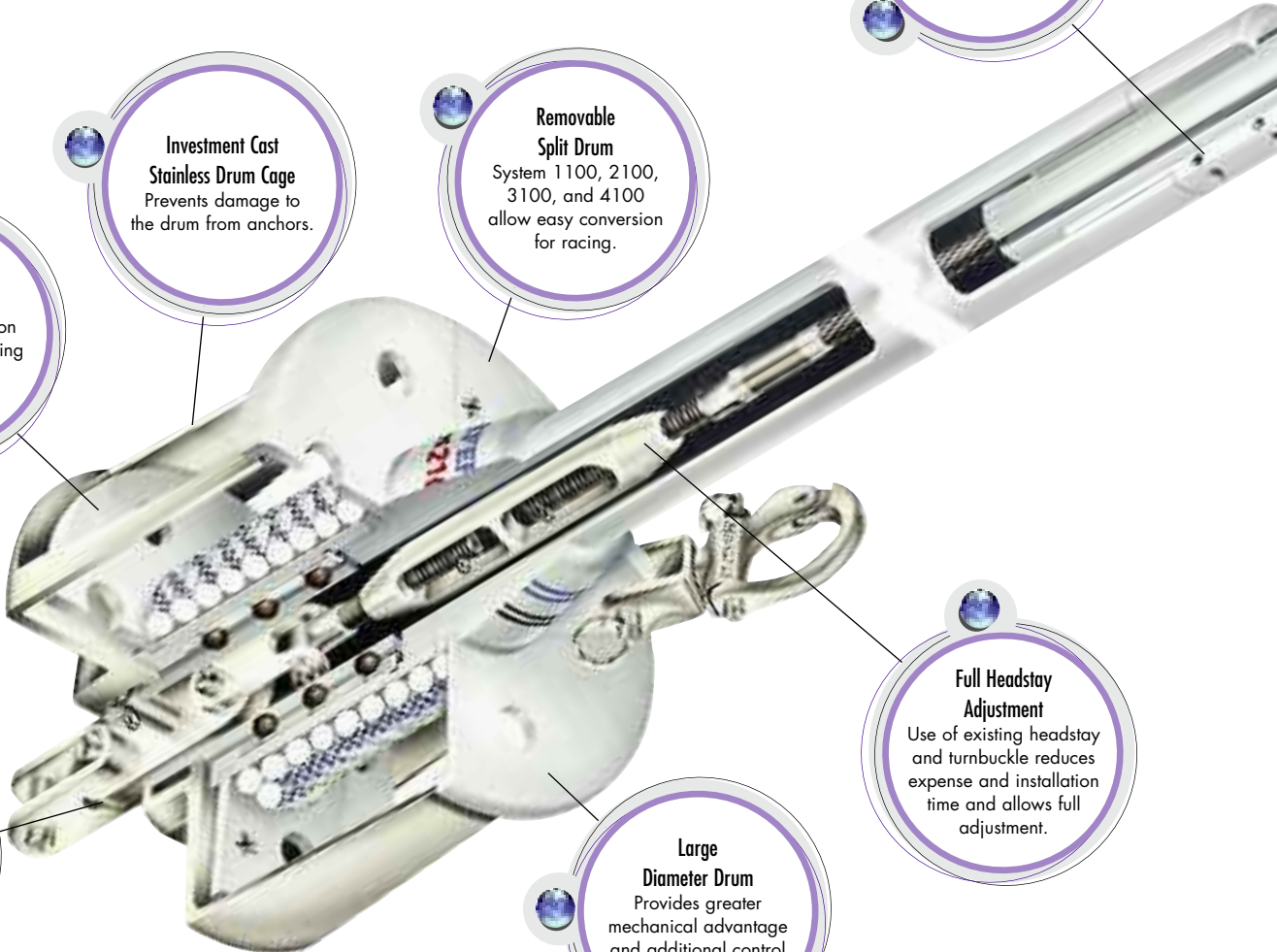

\*1100 offers two race bearing systems. Illustration represents design of System 2100, 3100, and 4100.

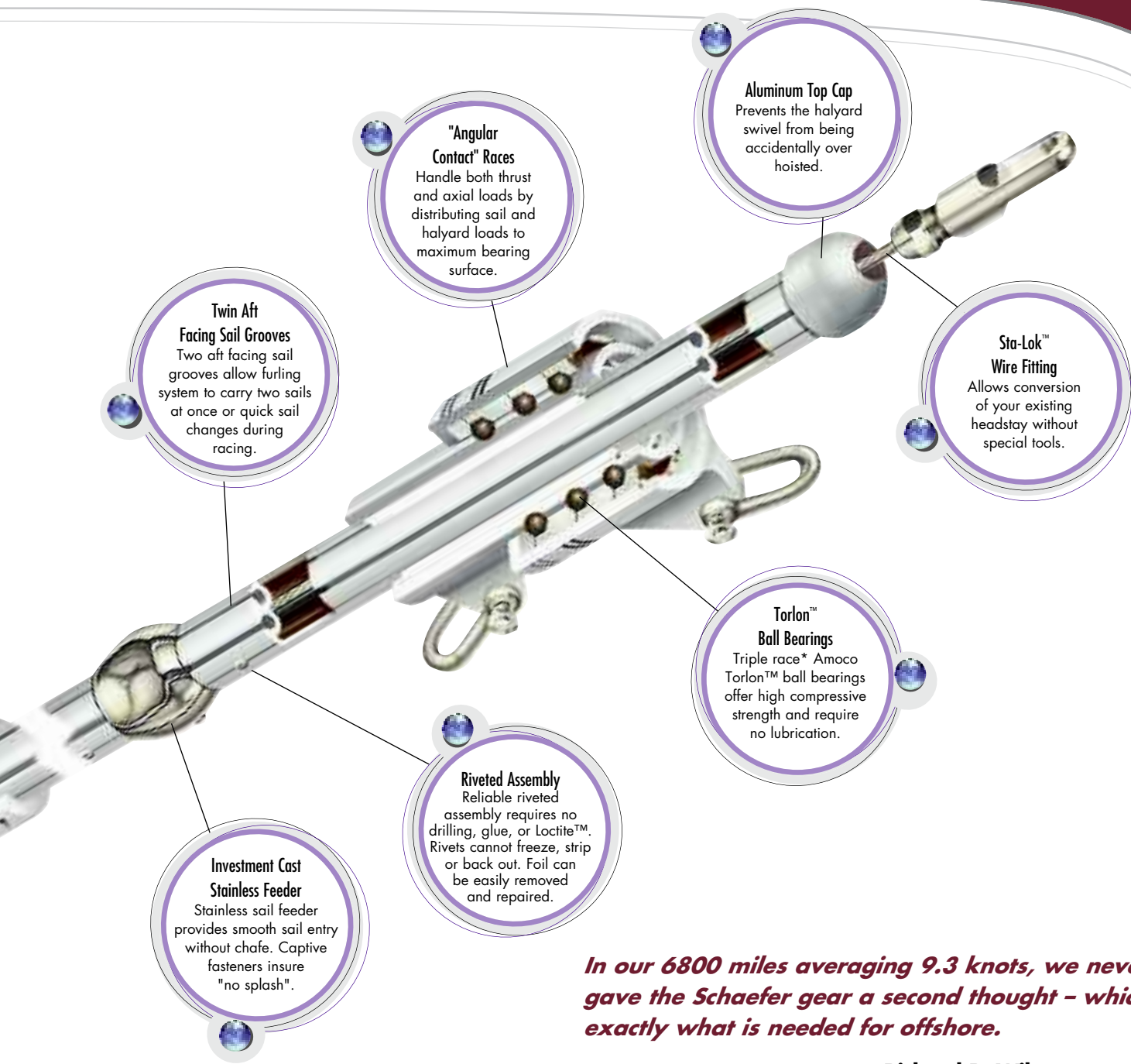

**Twin Aft Facing Sail Grooves**  
Two aft facing sail grooves allow furling system to carry two sails at once or quick sail changes during racing.

**"Angular Contact" Races**  
Handle both thrust and axial loads by distributing sail and halyard loads to maximum bearing surface.

**Aluminum Top Cap**  
Prevents the halyard swivel from being accidentally over hoisted.

**Sta-Lok™ Wire Fitting**  
Allows conversion of your existing headstay without special tools.

**Torlon™ Ball Bearings**  
Triple race\* Amoco Torlon™ ball bearings offer high compressive strength and require no lubrication.

**Riveted Assembly**  
Reliable riveted assembly requires no drilling, glue, or Loctite™. Rivets cannot freeze, strip or back out. Foil can be easily removed and repaired.

**Investment Cast Stainless Feeder**  
Stainless sail feeder provides smooth sail entry without chafe. Captive fasteners insure "no splash".

*In our 6800 miles averaging 9.3 knots, we never gave the Schaeffer gear a second thought - which is exactly what is needed for offshore.*

**Richard B. Wilson**  
Skipper of "Great American"  
Boston, MA







**SCHAEFER**  
**LEGENDARY STRENGTH**

## Need Help on the Foredeck?

Schaefer Roller Furling/Reefing allows you to set, furl and reef your genoa from the safety and convenience of the cockpit. You no longer need to scramble forward to hank on your luff or "tame the beast" of a flailing genoa dropped on the foredeck. Best of all, it's a one person job to handle even your big 150% genoa.

All Schaefer Systems are designed to be the strongest, best performing furling systems you can install on your boat. Combined with one "wide range" reefing sail, Schaefer Roller Furling/Reefing Systems can do the work of three or four conventional sails. Sailmakers can modify your existing sail or build a single sail that can perform well in winds from 0 to 35 knots.

Strength is just the beginning of why a Schaefer furler is the best system available. From years of research, we've developed a combination of features that rival any furler, at any price. That's because we've designed in, and improved, all the useful features of the world's best rated furlers, and eliminated the ideas that just didn't make sense.

The result is a furler that's not only strong, but easy to control, smooth and reliable. A proven design with thousands of miles of blue-water cruising—including the grueling Around-The-World-Race.

Whether you're upgrading your present boat or outfitting a new one, you'll have confidence knowing you've chosen the best jib furling/reefing system available. A furler with the trusted Schaefer name.



## Bearing Design: Open For Life

Schaefer's Torlon™ Bearings cannot corrode and ride in open, easily accessible races that require only occasional fresh water lubrication. These proven, high compression strength Torlon™ bearings provide low friction, and need only periodic flushing. Easy access flushing hole allows easy fresh water flushing.

## Headstay Adjustment: No Compromises

Schaefer Systems utilize your existing headstay and turnbuckle for reduced cost, allowing full turnbuckle adjustability, and optimum performance.

Our heavy-duty base toggle/link articulates to absorb side loads that might otherwise cause turnbuckle fatigue. Your turnbuckle is attached to the base toggle/link and is housed inside the system, easily accessible.

## Drum Design: Powerful, Open, Metal

Our powerful, large diameter drum provides you with the mechanical advantage you need for high sailing loads. Standard split drum plates allow for easy conversion to a full length headsail.\*

Attractive, stainless cage is open to allow possible overrides in the furling line to be identified and unwound quickly and easily.

Schaefer's CNC machined metal construction resists ultraviolet rays and abuse from anchor chains and poles mounted near the stemhead fitting.

## Ordering Information

System with Sta-Lok™ is designed to be easily installed on your existing standard wire headstay and turnbuckle. Complete kit includes Furler, Base Toggle/Link, Sta-Lok™ fitting, halyard restrainer and wire bearing liners\*\*.

System without Sta-Lok™ is designed for rod or pre-swaged wire headstays that are typically assembled by a professional rigger. Kit includes Furler, Base Toggle/Link, halyard restrainer and wire bearing liners\*\*.

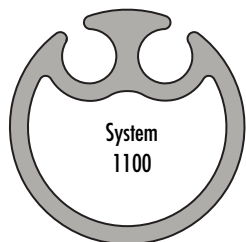

System  
1100

### System 1100

**Boats 27' to 31'** (8.2-9.5m)  
Built-in options in System 1100 allow for performance sailing: racing or cruising. Open, split drum makes conversion to full hoist headsails a snap. Round, twin groove extrusions allow for easy sail changes, or carrying dual "wing-on-wing" headsails downwind.

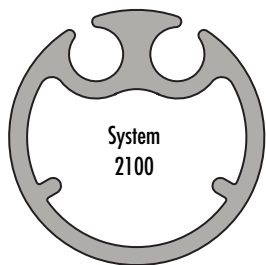

System  
2100

### System 2100

**Boats 30' to 42'** (9.1-12.8m)  
Designed to perform, built to last, System 2100 builds upon our 1100 System features with a robust bearing package for low friction, low maintenance furling for larger cruising boats. 126 tough Torlon™ bearings ride in specially shaped round races for maximum contact area.

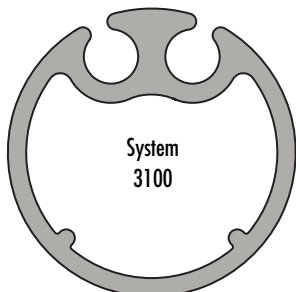

System  
3100

### System 3100

**Boats 41' to 55'** (12.5-16.8m)  
Large diameter drum in System 3100 increases the power to reef large headsails in heavy winds. Low-friction bearing inserts eliminate metal-to-metal headstay contact for less noise and easier turning. Stainless heli-coil inserts insure that you'll be able to take the furler apart, even after years in salt water.

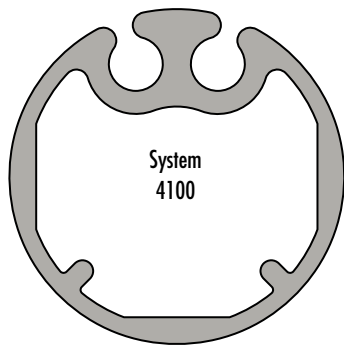

System  
4100

### System 4100

**Boats 54' to 65'** (16.5-19.8m)  
Our largest furler, System 4100 has the engineered-in strength to handle nearly the heaviest furling loads. Huge, 1/2" Torlon™ bearings are combined with a powerful, large diameter drum to provide efficient, rugged furling for the largest headsails. This tough, winchable design is an affordable alternative to the high costs associated with hydraulic or electric systems.

All extrusions shown full size.

#### System 1100

Length:	43' (13m) provided system length
Extrusions:	(6) 6' (2m) round, twin groove accepts #6 (3/16", 5mm) luff tape
Bearings:	3/8" (9.5mm) Torlon™. (34 in double race upper swivel, 34 in double race drum)
Drum Design:	Open/split 3-1/8" (79mm) dia.
Line Capacity:	50' (15.3m) 1/4" (6mm), 38' (11.6m) 5/6" (8mm)
Shipping Weight*:	25 lbs. (12kg) packaged furler, 36 lbs. (17kg) packaged extrusions

#### System 2100

Length:	49' 3" (15m) provided system length
Extrusions:	(7) 6' (2m) round, twin groove accepts #6 (3/16", 5mm) luff tape
Bearings:	3/8" (9.5mm) Torlon™. (63 in triple race upper swivel, 63 in triple race drum)
Drum Design:	Open/split 3-1/2" (89mm) dia.
Line Capacity:	70' (21.4m) 5/16" (8mm), 50' (15.2m) 7/16" (12mm)
Shipping Weight*:	28 lbs. (13kg) packaged furler, 38 lbs. (18kg) packaged extrusions

#### System 3100

Length:	64' 7.5" (19.7m) provided system length
Extrusions:	(8) 7' (2.13m) round, twin groove accepts #6 (3/16", 5mm) luff tape
Bearings:	3/8" (9.5mm) Torlon™. (78 in triple race upper swivel, 78 in triple race drum)
Drum Design:	Open/split 4-3/8" (111mm) dia.
Line Capacity:	90' (27.4m) 3/8" (10mm), 65' (19.8m) 7/16" (12mm)
Shipping Weight*:	43 lbs. (20kg) packaged furler, 67 lbs. (31kg) packaged extrusions

#### System 4100

Length:	78 9-1/4" (24m) provided system length
Extrusions:	(10) 7' (2.13m) round, twin groove accepts #6 (3/16", 5mm) luff tape
Bearings:	1/2" (13mm) Torlon™. (78 in triple race upper swivel, 78 in triple race drum)
Drum Design:	Open/split 6" dia.
Line Capacity:	130' (39.6m) 7/16" (12mm), 98' (29.9m) 1/2" (13mm)
Shipping Weight*:	72 lbs. (33kg) pkgd. furler, 65 lbs. (30kg), & 20 lbs. (10kg) pkgd. extrusions

\*\*Includes all shipping material

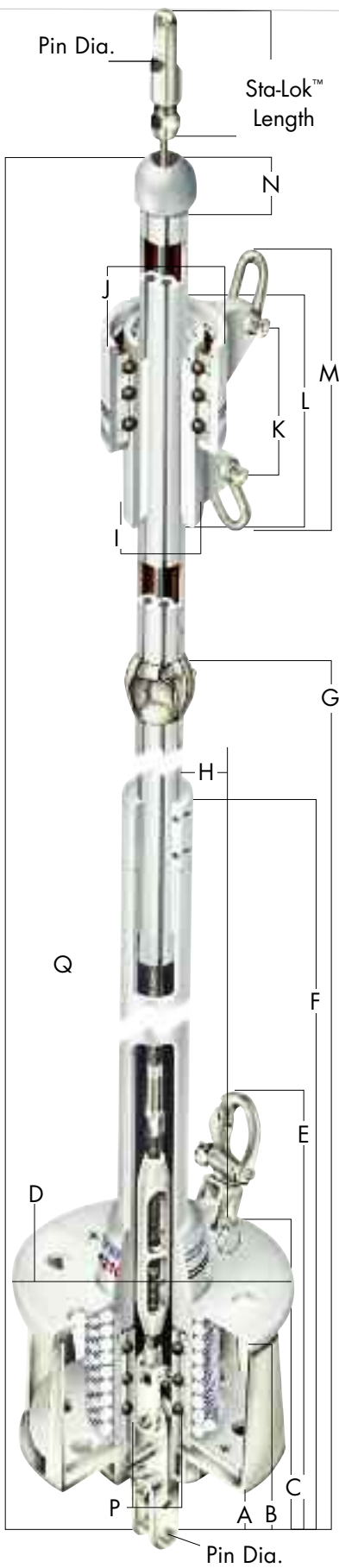

### Ordering Chart: System 1100, 2100, 3100, & 4100

	System Sta-Lok	Without Sta-Lok	Boat Size	Wire Dia.	Pin Dia.	Rod Size	Sta-Lok Length	System Length
System 1100	1100-01	1100-44	27'-31" (8.2-9.5m)	3/16" (5mm)	3/8" (9.5mm)	-4 (4.37mm)	2-1/8" (54mm)	43' (13m)
	1100-02	1100-55	27'-31" (8.2-9.5m)	7/32" (5.5mm)	7/16" (12mm)	-6 (5.03mm)	2-1/2" (64mm)	43' (13m)
	1100-03	1100-66	27'-31" (8.2-9.5m)	1/4" (6mm)	1/2" (13mm)	-8 A(5.72mm)	2-9/16" (65mm)	43' (13m)
	1100-04*	(use 1100-66*)	27'-31" (8.2-9.5m)	9/32" (7mm)	1/2" (13mm)	-10 (6.35mm)	3" (76mm)	43' (13m)
System 2100	2100-01	2100-44	30'-42" (9.1-12.8m)	1/4" (6mm)	1/2" (13mm)	-8 (5.72mm)	2-9/16" (65mm)	49', 3" (15m)
	2100-02	(use 2100-44)	30'-42" (9.1-12.8m)	9/32" (7mm)	1/2" (13mm)	-10 (6.35mm)	3" (76mm)	49', 3" (15m)
	2100-03	2100-55	30'-42" (9.1-12.8m)	5/16" (8mm)	5/8" (16mm)	-12 (7.14mm)	3-1/4" (83mm)	49', 3" (15m)
	2100-04*	(use 2100-55*)	30'-42" (9.1-12.8m)	3/8" (10mm)	5/8" (16mm)	-17 (8.38mm)	3-3/4" (95mm)	49', 3" (15m)
System 3100	3100-01	3100-44	41'-55" (12.5-16.8m)	5/16" (8mm)	5/8" (16mm)	-12 (7.14mm)	3-1/4" (83mm)	64', 7 1/2" (19.7m)
	3100-02	(use 3100-44)	41'-55" (12.5-16.8m)	3/8" (10mm)	5/8" (16mm)	-17 (8.38mm)	3-3/4" (95mm)	64', 7 1/2" (19.7m)
	3100-03	3100-55	41'-55" (12.5-16.8m)	7/16" (11mm)	3/4" (19mm)	-22 (9.53mm)	3-3/4" (95mm)	64', 7 1/2" (19.7m)
	3100-04	3100-66	41'-55" (12.5-16.8m)	1/2" (12.7mm)	7/8" (22mm)	-22 (9.53mm)	4-5/8" (118mm)	64', 7 1/2" (19.7m)
System 4100	4100-01	4100-44	54'-65" (16.5-19.8m)	7/16" (12mm)	3/4" (19mm)	-30 (11.1mm)	4-5/8" (118mm)	78', 9-1/4" (24m)
	4100-02	4100-55	54'-65" (16.5-19.8m)	1/2" (12.7mm)	7/8" (22mm)	-30 (11.1mm)	4-5/8" (118mm)	78', 9-1/4" (24m)
	4100-03	(use 4100-55)	54'-65" (16.5-19.8m)	9/16" (14.2mm)	7/8" (22mm)	-40 (12.7mm)	5-1/2" (140mm)	78', 9-1/4" (24m)

Care must be taken when ordering furling systems with long toggle/links. The standard systems come with the standard toggle/link automatically. If a long toggle/link is required, order the generic system with no toggle, i.e., the 1100, 2100 or the 3100 and then order the appropriate long toggle/link.

### Dimensional Chart:

	System 1100	System 2100	System 3100	System 4100
A	3-1/4" (83mm)	3-3/4" (95mm)	4-3/4" (121mm)	6" (152mm)
B	7-1/2" (190mm)	8-5/8" (219mm)	10-1/8" (257mm)	14" (356mm)
C	8-11/16" (221mm)	10" (254mm)	11-13/16" (300mm)	16-1/2" (419mm)
D	6-3/4" (171mm)	8-1/4" (210mm)	11-1/8" (283mm)	14" (356mm)
E	11-1/8" (283mm)	13" (330mm)	15-7/8" (403mm)	18-1/2" (470mm)
F	27-1/8" (689mm)	29-5/8" (752mm)	41-1/4" (1.05m)	43-1/2" (1.10m)
G	47-1/2" (1.20m)	50" (1.27m)	60-1/2" (1.54m)	62-1/4" (1.58m)
H	1-3/16" (30mm)	1-1/2" (38mm)	1-1/2" (38mm)	2-1/2" (64mm)
I	2" (51mm)	2-1/2" (64mm)	2-1/2" (64mm)	2-3/4" (70mm)
J	3-1/8" (79mm)	3-11/16" (94mm)	4-3/8" (111mm)	5-1/8" (130mm)
K	3-11/16" (94mm)	4-3/8" (111mm)	4-3/8" (111mm)	5" (127mm)
L	5-3/16" (132mm)	6-1/4" (159mm)	6-5/8" (168mm)	8" (203mm)
M	6" (153mm)	7-1/4" (184mm)	7-3/4" (197mm)	9-1/2" (241mm)
N	1-1/8" (29mm)	1-1/4" (32mm)	2-7/16" (62mm)	2-3/4" (70mm)
O	43' (13m)	49', 3" (15m)	64', 7-1/2" (19.7m)	78', 9-1/4" (24m)
P	1-5/8" (41mm)	2" (51mm)	2-5/8" (67mm)	3-1/2" (89mm)

#### Rod Information

All Schaefer furling systems are easily adaptable to rod headstays. Extrusions can be installed after rod is shortened and re-headed.

#### System 1100

Extrusions pass up to a 1/2" (13mm) dia. nose  
Joints accept -4, -6, & -8 rod

#### System 2100

Extrusions pass up to a 5/8" (16mm) dia. nose  
Joints accept -8, -10, & -12 rod

#### System 3100

Extrusions pass up to a 3/4" (19mm) dia. nose  
Joints accept -12, -17, -22 & -30 rod

#### System 4100

Extrusions pass up to a 3/4" (25mm) dia. nose  
Joints accept -22, -30, & -40 rod as well as up to 14mm Dyform

- Boat sizes are approximate for typical wire/pin combinations
- Wire size and pin diameter are critical sizing/ordering dimensions
- All Schaefer Furlers are easily adaptable to wire or rod headstays
- Additional extrusions may be ordered for custom length systems
- Custom Sta-Lok™ and base toggle/link combinations available



## Long Integral Toggle Links

Replaces Schaefer standard, integral toggle link to raise bottom drum assembly off deck.

	Item	Pin Dia	Drum Height	Overall Pin/Pin	Additional From Std. *	W	T	Weight
1100	1100-24	3/8" (10mm)	9-1/4" (235mm)	10-1/8" (257mm)	6" (152mm)	1-1/2" (38mm)	1/4" (6mm)	1 lb. 5.8 oz. (618g)
	1100-23	7/16" (11mm)	9-1/4" (235mm)	10-1/8" (257mm)	6" (152mm)	1-1/2" (38mm)	1/4" (6mm)	1 lb. 5.8 oz. (618g)
	1100-22	1/2" (13mm)	9-1/4" (235mm)	10-1/8" (257mm)	6" (152mm)	1-1/2" (38mm)	1/4" (6mm)	1 lb. 5.8 oz. (618g)
2100	2100-24	1/2" (13mm)	11-1/4" (286mm)	12-1/8" (309mm)	7-1/2" (190mm)	1-1/2" (38mm)	1/2" (13mm)	2 lbs. 15 oz. (1.33 kg)
	2100-22	5/8" (16mm)	11-1/4" (286mm)	12-1/8" (309mm)	7-1/2" (190mm)	1-1/2" (38mm)	1/2" (13mm)	2 lbs. 15 oz. (1.33 kg)
3100	3100-22	5/8" (16mm)	13-3/4" (350mm)	15" (382mm)	9" (229mm)	2" (51mm)	1/2" (13mm)	5 lbs. 5.4 oz. (2.42 kg)
	3100-24	3/4" (19mm)	13-3/4" (350mm)	15" (382mm)	9" (229mm)	2" (51mm)	1/2" (13mm)	5 lbs. 5.4 oz. (2.42 kg)
	3100-28	7/8" (22mm)	13-3/4" (350mm)	15" (382mm)	9" (229mm)	2" (51mm)	5/8" (16mm)	6 lbs. (2.73 kg)

\*Represents additional length over Schaefer Standard Integral Toggle length.

\*\*Custom Long, Integral Toggle Links available for System 4100.

## Extrusion Extension Kits

Tall rigs may require an additional extrusion for headstay lengths greater than our standard lengths. Kit includes one full length extrusion, one torque joint for connection of extrusions, bearing liners, and rivets.



	Item	Description	L	Weight
1100	1100-10	System 1100 Extension Kit	6 (2m)	3 lbs. 10 oz. (1.63kg)
2100	2100-10	System 2100 Extension Kit	6 (2m)	3 lbs. 11 oz. (1.67kg)
3100	3100-10	System 3100 Extension Kit	7 (2.13m)	5 lbs. (2.28kg)
4100	4100-10	System 4100 Extension Kit	7 (2.13m)	6 lbs. 11 oz. (3.02kg)

## Halyard Restrainers

Schaefer's Halyard Restrainers eliminate the possibility of halyard wrap by simply deflecting the halyard away from your headstay.



32-80



78-74  
78-75



76-30

## Sail Pre-Feeder

Compatible with all systems, our Pre-Feeder allows easy sail hoisting whether racing or sailing shorthanded. Use with #5 - #8 Luff Tapes. W = 2oz.

Item	Descrip.	Mast Radius	Const.	Sheave Dia.	Max Line/Wire	L	W	SWL	Weight
78-74	Halyard Restrainer**	1-3/8" (35 mm)	Stainless	---	3/8" wire (9mm)	7/8" (22mm)	1-3/16" (30mm)	750 lbs. (340kg)	2 oz. (57g)
78-75	Halyard Restrainer**	3" (76mm)	Stainless	---	5/8" wire (16mm)	2" (51mm)	2-3/4" (70mm)	2000 lbs. (907kg)	4 oz. (113g)
32-80	Restrainer Block*	3" (76mm)	Stainless/Aluminum	1-7/16" (36mm)	1/2" (12mm) 3/16" (5mm)	2-5/16" (59mm)	1-1/4" (57mm)	2000 lbs. (907kg)	4.5 oz. (128g)

\*Secured with four #10 RH machine screws tapped into the spar section, Schaefer's halyard restrainers are designed to accept a maximum 15° entry and 45° exit angle. \*\*Secured with two #10RH Machine Screws.

## "Clamp-On" Stanchion & Pulpit Furling Blocks

Excellent for leading your furling line aft along stanchion bases to cockpit. Contoured base and stainless brackets allow for easy, secure installation. Spring mounted pulpit block articulates to adjust for the final lead into furling system. Ball Bearing Delrin™ sheaves provide low friction.

Item	Descrip.	Stanchion Size	Cheek Sheave	Sheave Dia.	Max Line	L	W	SWL	Weight
78-53	"Clamp-On" Bullseye	1" (25mm)	Stainless/Poly	3/8" (9mm)	3/8" (9mm)	2-3/8" (60mm)	1-5/32" (30mm)	250 lbs. (112kg)	2.5 oz. (71g)
300-34	"Clamp-On" Stanchion Block	1" (25mm)	Stainless/Delrin™	1-7/16" (37mm)	1/2" (13mm)	2-25/32" (71mm)	2-3/16" (57mm)	1000 lbs. (450kg)	3 oz. (85g)
300-35	"Clamp-On" Pulpit Block	1" (25mm)	Stainless/Delrin™	1-7/16" (37mm)	1/2" (13mm)	4-11/32" (111mm)	1-9/16" (40mm)	1000 lbs. (450kg)	4 oz. (113g)
500-35	"Clamp-On" Pulpit Block	1" / 1-1/4" (25mm) (32mm)	Stainless/Delrin™	2" (51mm)	1/2" (13mm)	4-3/4" (145mm)	1-1/8" (29mm)	1200 lbs. (544kg)	8.3 oz. (162 g)



78-53



300-34



300-35



506-44

## "Clear Step" Outside Lead Furling Blocks

This unique design leads your furling control line outside of your stanchions for a clean lead aft to the cockpit. "Clear Step" maximizes deck area by clearing your deck layout from excess lines.

Item	Descrip.	Stanchion Size	Cheek Sheave	Sheave Dia.	Max Line	L	W	SWL	Weight
506-44	Clear Step/Furling Block	1" (25mm)	Stainless/Delrin™	2-3/8" (60mm)	1/2" (12mm)	3-1/8" (79mm)	1-1/8" (29mm)	750 lbs. (340kg)	5 oz. (142g)
706-44	Clear Step II/Furling Block	1-1/4"* (32mm)*	Stainless/Aluminum	2-7/8" (73mm)	5/8" (16mm)	3-5/8" (92mm)	1-1/8" (29mm)	850 lbs. (390kg)	7 oz. (198g)

\*up to 1 3/8" (35mm)

## "Clamp-On" & "Clear Step" Block and Line Kits

Complete Kit has everything you need to set-up your furling line for a clean lead aft. Pulpit block, stanchion blocks and the appropriate line for typical furling installations for both kits.

Item	Descrip.	Block Quantity	Line Length	Line Dia.	Weight
300-75	Clamp-On Blocks Only	1, 300-35 3, 300-34	---	1/2" (13mm)	15 oz. (425g)
300-76	Clear Step Blocks Only	1, 300-35 3, 506-44	---	1/2" (13mm)	1 lb. 4oz. (567g)
CF-500-19	CF-500 Lead Kit	3, 78-53	35' (11m)	1/4" (6mm)	1 lb. 4oz. (567g)
CF-700-19	CF-700 Lead Kit	1, CF-700-22 2, 78-53	45' (13m)	5/16" (8mm)	1 lb. 6 oz. (624g)
1100-19	Clamp-On 1100 Kit	1, 300-35 2, 300-34	50' (15m)	1/4" (6mm)	1 lb. 15 oz. (879g)
1100-20	Clear Step 1100 Kit	1, 300-35 2, 506-44	50' (15m)	1/4" (6mm)	2 lb. 1 oz. (879g)
2100-19	Clamp-On 2100 Kit	1, 300-35 3, 300-34	70' (21m)	5/16" (8mm)	3 lbs. 10 oz. (1.64kg)
2100-20	Clear Step 2100 Kit	1, 300-35 3, 506-44	70' (21m)	5/16" (8mm)	4 lbs. (1.64kg)
3100-19	Clamp-On 3100 Kit	1, 500-35 4, 300-34	90' (27m)	3/8" (10mm)	5 lbs. 1 oz. (2.29kg)
3100-20	Clear Step 3100 Kit	1, 500-35 4, 506-44	90' (27m)	3/8" (10mm)	5 lbs. 6 oz. (2.29kg)



300-75



300-76

\*Custom line kits available for System 4100. Call Schaefer Customer Service for details.

A  
Measurement  
To Top Of System



## Common Features

**Two-Piece interlocking PVC Geon™ extrusion.**

**Furling and reefing capabilities.**

**Elegant Stainless Steel Sail Feeder with Captive Fasteners.**

**Double Race of Torlon Ball Bearings in the Upper Swivel and Lower Drum.**

**Open Drum design with Stainless Cage.**

Single Piece torque tube and drum of high strength, long-grain Nylon Composite with UV inhibitors.

A  
Measurement  
To Top Of System



Single piece torque tube and drum of machined aluminum anodized for strength and corrosion resistance.

### Dimensional Chart:

	CF-500	CF-700
A	31 5" (9.6m)	38 (11.6m)
B	15-3/4" (400mm)	20-3/4" ( mm)
C	5-3/8" (136mm)	5-1/2" (140mm)
D	5" (127mm)	6-1/8" (155mm)
E	3" (76mm)	4" (111mm)
F	4-7/8" (123mm)	6-1/2" (165mm)
G	1-7/8" (48mm)	3-1/4" (82mm)

CF-500  
"It rates a Best Buy,  
Hands down."

Small Boat Furler  
Comparison  
"Practical Sailor"

## CF-500

## CF-700

## Snapfurl Headsail Reefing and Furling Systems

Snapfurl represents the latest in quality Schaefer design and engineering. We offer two models for boats up to 28'. Both systems feature a unique interlocking Round Geon™ PVC foil that allows for owner installation directly over your existing headstay with no modifications in less than an hour. The foils also lend themselves to trailerable boats to ease the problems with mast raising or lowering.

The CF-500 features a reinforced injection molded Torque Tube and Upper Swivel for incredible strength and lightness. The larger CF-700 takes advantage of Computer machining for it's Aluminum Torque Tube, Drum and Upper Swivel. Both Snapfurl systems feature a double race of Torlon™ Ball bearings allow for easy reefing or furling at any time. Snapfurl makes it easy to be sailing in no time!

SnapFurl is the perfect headsail system for trailerable boats.



### SnapFurl CF-500

Boats 16' to 24' approx. (6.1-8.5m)

The smallest of our over-the-headstay systems utilizing Torlon™ bearing races, composite torque tube and two-piece snap together interlocking high-grade PVC extrusion. Offers lightweight, high strength and smooth operation with very easy installation.

System CF-500 SnapFurl

#### SnapFurl CF-500

Length:	31.1' (9.5m) provided system length
Extrusions:	one length, single groove accepts #5 luff tape
Bearings:	3/8" (9.5mm) Torlon™ (31) in double race upper swivel 1/4" (6mm) (40) in double race drum.
Drum Design:	Open, 2" (51mm) dia.
Line Capacity:	25' (7.6m) 1/4" (6mm), 19' (5.8m) 5/16" (8mm)
Shipping Weight*:	CF500 15.7 lbs.



### SnapFurl CF-700

Boats 24' to 28' approx. (7.3-8.5m)

The CF-700 features a double race of Torlon™ ball bearings, machined aluminum torque tube and high quality two-piece snap together interlocking high grade PVC extrusion. Offers lightweight, high strength and smooth operation with easy installation.

System CF-700 SnapFurl

#### SnapFurl CF-700

Length:	38' (11.6m) provided system length
Extrusions:	one length, single groove accepts #6 luff tape
Bearings:	3/8" (9.5mm) Torlon™ (32 each) (9.5mm) Torlon (32 each) upper swivel
Drum Design:	Open, 3" (76mm) dia.
Line Capacity:	40' (12.2m) 1/4" (6mm), 30' (9.1m) 5/16" (8mm)
Shipping Weight*:	CF-700 32 lbs.

## Fairlead Arm, SnapFurl

Optional Stainless Steel fairlead arm for SnapFurls have mounted bullseye for applications on boats that may not have bow pulpits.

**CF-500-22** 3 oz. (86g), Length: 1-5/8" (41mm)

**CF-700-22** 4 oz. (114g), Length: 2-1/2" (64mm)



CF-700-22



1. High compression strength Torlon™ bearings ride in precision machined races providing low friction. Durable design resists corrosion and is easily flushed for minimal maintenance.

2. #650 Drum and swivel features 5 bearing races.



### "Free-Furling"

Convenient and reliable "Free-Furling" allows you to quickly set or furl your jib or code zero sail without leaving the safety of the cockpit. The sail furls and unfurls on its own luff wire or rope and is easily removed for use on trailerable boats or stows easily on larger boats.

These lightweight swivels utilize clear anodized, marine grade aluminum and contain hi-load Torlon™ bearings to ensure smooth and reliable performance. Precision computer machined races maximize bearing contact area for ultimate strength and durability under load providing you with safe, easy furling.

Optional cam arm brackets and snap shackle adapters fit onto Schaefer System 550 and 650 furlers to make it easy to give your staysail a whirl!



## How Schaefer "Free-Furling" Works

When you are ready to furl, slack off the sheet to let the jib luff. While easing the sheet, pull the furling line. When you are ready to set the jib, uncleat the furling line in the cockpit and simply pull the jib sheet, trimming as you would any other jib.

The jib furls and unfurls on the jib's own built-in luff wire. It's that easy!

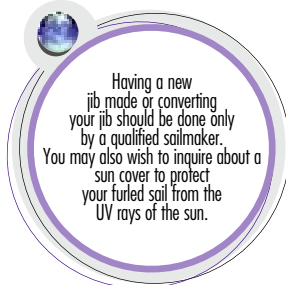

\* Length perpendicular to headstay

	Item	Descrip.	Boat Size Jib	*Boat Size Staysail/Code 0	Max Wire	Pin Dia.	Max LP	Max Luff	Line Capacity	L	W	T	FreeFurl Load	SWL	Weight
System 350	350-01	Upper Swivel	14'-19' (4.3m-5.8m)	---	1/8" (3mm)	1/4" (6mm)	10' 6" (3.2m)	30' (9.1m)	---	2-3/8" (60mm)	1" (25mm)	5/16" (8mm)	550 lbs. (250kg)	800 lbs. (364kg)	2.4oz. (68g)
	350-02	Furling Drum	14'-19' (4.3m-5.8m)	---	1/8" (3mm)	1/4" (6mm)	10' 6" (3.2m)	30' (9.1m)	11' 5/32" (3.3m, 4mm)	2-3/8" (60mm)	2-3/4" (70mm)	5/16" (8mm)	550 lbs. (250kg)	800 lbs. (364kg)	5.1oz. (145g)
	350-00	Swivel/Drum/Line Kit	14'-19' (4.3m-5.8m)	---	1/8" (3mm)	1/4" (6mm)	10' 6" (3.2m)	30' (9.1m)	30' 5/32"* (9.1m, 4mm)	---	---	---	550 lbs. (250kg)	800 lbs. (364kg)	10.8oz. (306g)
System 550	550-01	Upper Swivel	19'-25' (5.8m-7.6m)	Up to 34 (10.4m)	3/16" (5mm)	5/16" (8mm)	16' (4.9m)	45' (13.7m)	---	4" (100mm)	1-1/2" (38mm)	3/8" (10mm)	1000 lbs. (544kg)	1800 lbs. (818kg)	7.1oz. (201g)
	550-02	Furling Drum	19'-25' (5.8m-7.6m)	Up to 34 (10.4m)	3/16" (5mm)	5/16" (8mm)	16' (4.9m)	45' (13.7m)	17' 3/16" (5.2m, 5mm)	4" (100mm)	4-1/8" (103mm)	3/8" (10mm)	1000 lbs. (544kg)	1800 lbs. (818kg)	15.5oz. (439g)
	550-00	Swivel/Drum/Line Kit	19'-25' (5.8m-7.6m)	Up to 34 (10.4m)	3/16" (5mm)	5/16" (8mm)	16' (4.9m)	45' (13.7m)	35' 3/16" (10.7m, 5mm)	---	---	---	1000 lbs. (544kg)	1800 lbs. (818kg)	1 lb. 12.9oz. (819g)
System 650	650-01	Upper Swivel	25'-31' (7.6m-9.4m)	Up to 41' (12.5m)	1/4" (6mm)	3/8" (10mm)	26' (7.9m)	65' (19.8m)	---	4-7/8" (123mm)	1-3/4" (45mm)	7/16" (11mm)	2200 lbs. (998kg)	3400 lbs. (1550kg)	12.1oz. (345g)
	650-02	Furling Drum	25'-31' (7.6m-9.4m)	Up to 41' (12.5m)	1/4" (6mm)	3/8" (10mm)	26' (7.9m)	65' (19.8m)	28' 1/4" (8.5m, 6mm)	4-7/8" (123mm)	5-1/2" (140mm)	7/16" (11mm)	2200 lbs. (998kg)	3400 lbs. (1550kg)	27.0oz. (766g)
	650-00	Swivel/Drum/Line Kit	25'-31' (7.6m-9.4m)	Up to 41' (12.5m)	1/4" (6mm)	3/8" (10mm)	26' (7.9m)	65' (19.8m)	50' 1/4" (15.2m, 6mm)	---	---	---	2200 lbs. (998kg)	3400 lbs. (1550kg)	3 lbs. 6.3oz. (1.5kg)

\*Code Zero sails create unique loads, please contact Schaefer

Item	Descrip.	L	W	T	SWL	Weight
550-16	Arm Bracket/Bullseye	6-3/16" (157mm)	2-5/16" (59mm)	2-9/32" (58mm)	1800 lbs. (818kg)	3.3 oz. (94g)
550-17	Arm Bracket/Bullseye/Cam	6-3/16" (157mm)	2-5/16" (59mm)	2-9/32" (58mm)	1800 lbs. (818kg)	7.1 oz. (201g)
550-19	Snap Shackle Adapter	2-13/16" (71mm)	1-9/32" (32mm)	3/8" (10mm)	1800 lbs. (818kg)	2.5 oz. (71g)
650-16	Arm Bracket/Bullseye	7-11/16" (195mm)	2-5/16" (59mm)	2-1/2" (64mm)	3400 lbs. (1550kg)	5.1 oz. (145g)
650-17	Arm Bracket/Bullseye/Cam	7-11/16" (195mm)	2-5/16" (59mm)	2-1/2" (64mm)	3400 lbs. (1550kg)	7.8 oz. (221g)
650-19	Snap Shackle Adapter	3-1/2" (89mm)	1-5/8" (41mm)	13/32" (11mm)	3400 lbs. (1550kg)	4.4 oz. (125g)

\*Line provided covers most typical installations.

## Staysail / Code Zero Adapters

With the addition of an arm bracket and snap shackle, "Free-Furling" swivels can be easily modified to staysail or Code Zero Furling systems. Choose from any of these options to solve your custom application.



**SCHAEFER**  
LEGENDARY STRENGTH

# Boom Furling

Schaefer Marine's Boom Furling system is the result of years of Research, Design and Sailing. Proven over thousands of miles of use, our unique Patented Articulating Sail Track enables you to reef or furl on any point of sail all from the safety of the cockpit.

Boom furling has always been a great idea. It took Schaefer engineering to make it a flawless one.

**Full Batten Main**  
Schaefer's Boom Furler uses Full Batten Mainsails permitting large roached sails with your choice of sail cloth!

**Oversized Torlon™ Bearings**  
The Torlon bearings are set in angular contact races to absorb high compression loads and minimize friction

**Aft Drum**  
The Aft Drum allows for perfect alignment between the articulating Luff Track and gooseneck for easy reefing and furling on all points of sail.

**Snubber**  
Unique 4.25" Schaefer Snubber engineered to add friction to your halyard for more control when reefing or furling.

**Boom Claw**  
Internal Boom Claw supports center Mandrel when reefing.

27-013

**Articulating Sail Track**  
Sail Track supports full battens. This allows the luff tape to travel without friction or the possibility of tearing.

**Articulating Sail Track**  
Articulates with the gooseneck for perfect alignment.

**In-Boom Furling**  
Schaefer's In-Boom Furling System keeps weight and mechanics low and accessible.

**Fixed Boom Vang**  
Heavy duty fixed rigid vang for correct alignment and support.

**Cockpit leads**  
Choose from our wide variety of lead blocks to ensure low friction leads to the cockpit.

Illustration shown is a representative only and final product may vary.

**Call 508-995-9511 for Customer Service**

# Details Make The Difference



A double race of Torlon™ Ball Bearings are placed in each end fitting to reduce friction for easier reefing and furling.



Every system includes our solid adjustable Boom Vang keeping your boom at a consistent level for worry-free furling.



Computer Machined end fittings ensure strength and allow for a double race of Torlon™ Ball Bearings.

# Why Schaefer Boom Furling

## Articulating Luff

Patented Luff Track articulates with the gooseneck for perfect alignment allowing reefing or furling on any point of sail.



## Batten End Receptacle

Schaefer Batten End Receptacles and sail luff tape are supported by Schaefer's sailtrack, absorbing batten compression loads and reducing sail friction.



## Track Assembly

All joints and slides are precision machined and Anodized Aluminum for strength and durability. The Articulating Luff Track is made from Geon™ PVC with UV inhibitors.

## Aft Drum

The perfect alignment between the articulating Luff Track and gooseneck is made possible by our Computer machined Aft Furling Drum.



## Open Boom Ends

Precision machining allows for visual inspection of the sail and furling line during operation as well as low friction Torton™ Ball Bearings.

## Solid Vang

Correct alignment and support is accomplished by a Solid Adjustable Boom Vang.



Schaefer Boom Furling is available through a network of qualified dealers. Please contact Schaefer Marine with any questions.

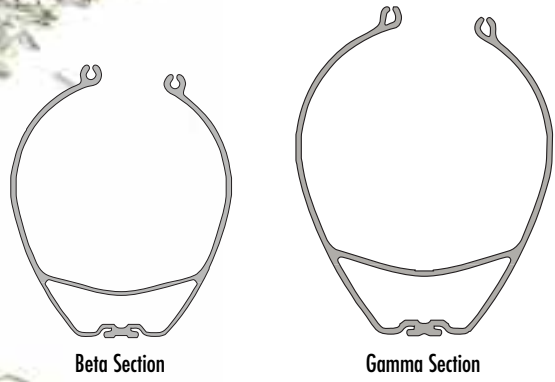

Model	Approx. Boat Size	Material	Size W x H	Max "P" Dimension*	Max "E" Dimension
Beta	34'-42' (10.4m-12.8m)	6063 T5 Aluminum	8.40" x 10.31" (213mm x 262mm)	44"* (13.4m)	16' (4.9m)
Gamma	40'-53' (12.2m-16.1m)	6063 T5 Aluminum	9.65" x 12.32" (245mm x 312mm)	53"* (16.1m)	20' 4" (16.1m)

\*Approx. (luff length)

Call 508-995-9511 for Customer Service



# TuffLuff

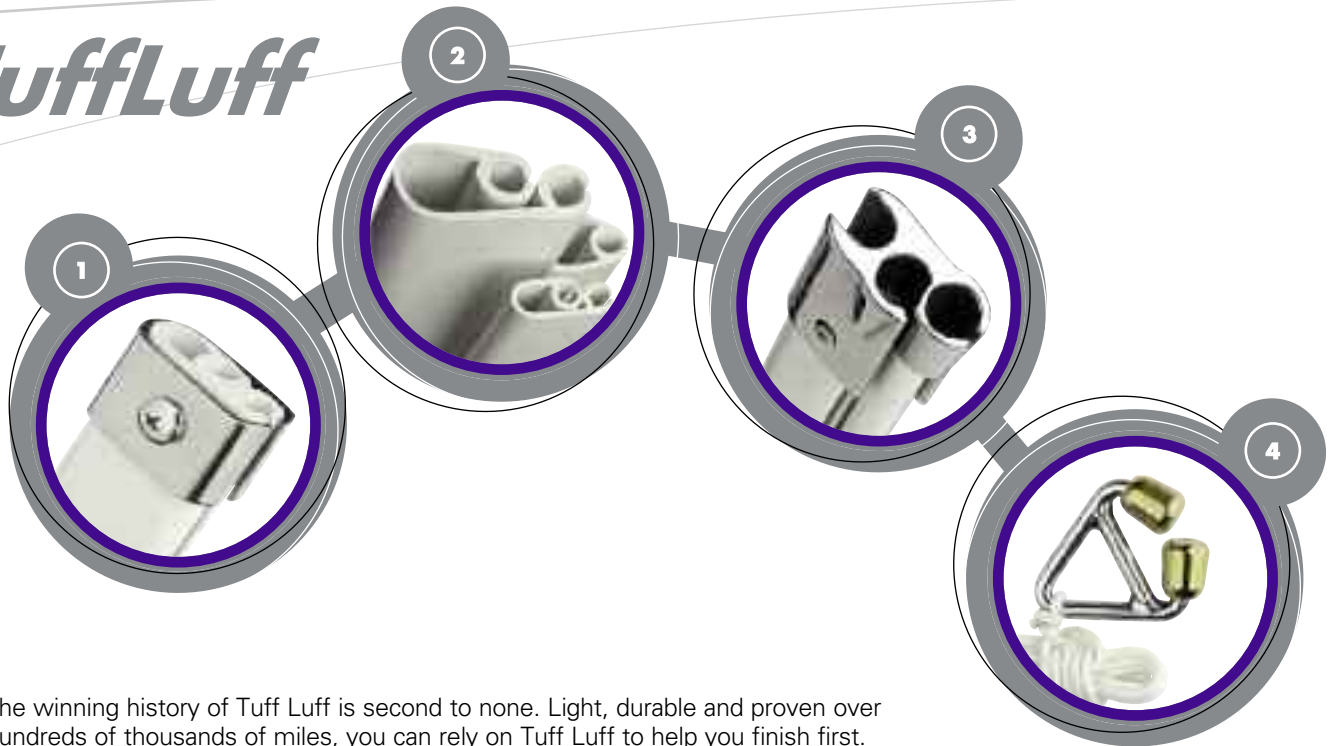

The winning history of Tuff Luff is second to none. Light, durable and proven over hundreds of thousands of miles, you can rely on Tuff Luff to help you finish first. Twin grooved foils allow for easy and fast sail changes keeping you in front. Available in sizes to fit wire/rod up to 3/4" (20mm), -76 rod.

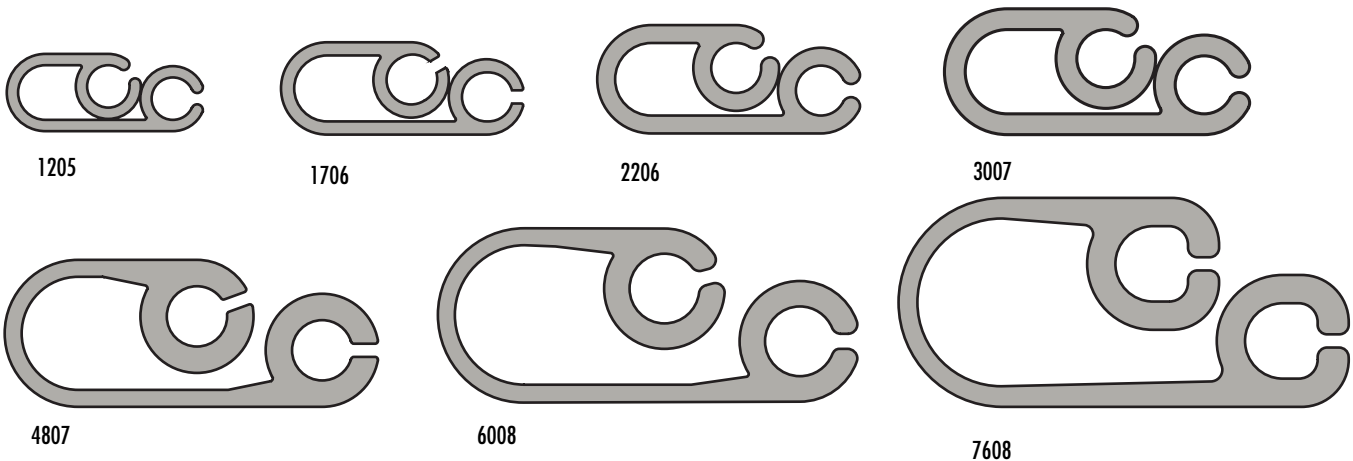

**1 Top Cap**  
 Made of tough Stainless Steel, top caps safeguard against chafe caused by crossed or improperly lead halyards. The top cap is aerodynamic and extremely light to minimize weight aloft. It installs in minutes.

**2 Extrusion**  
 Replacing your TuffLuff foil is literally a snap. We offer spare extrusions for every system, cut to standard lengths. The foil bottom is finished to accept the feeder.

**3 Feeder**  
 Precision engineered feeders, made of high quality 316 Stainless Steel, fit neatly over the finished TuffLuff foil. The feeder guides the sail luff into the extrusion for a flawless hoist every time.

**4 Prefeeder**  
 Oversized silicon bronze rollers smooth out the sail on its way to the feeder, assuring a perfect set and eliminating the need for crew to hand-feed the sail.

**5 UHMW Wear Tape**  
 Protect your TuffLuff extrusion from Sheet chafing. See chart for ordering information.

## How to select the proper Extrusion:

Select the maximum headstay which is greater or equal to your boat's headstay.

Match maximum headstay with your boat's headstay diameter. Please refer to our Specifications Chart for detailed information.

### Complete Kits Include:

- Extrusion
- Feeder
- Prefeeder-Lanyard
- Instructions
- TuffLuff Tape
- Sailing Tips
- (2) Spacer Tubes



Complete Kit	Extrusion Only	Extrusion Length	Max Head Stay Length	Max Wire	Max Rod	Luff Tape	Extrusion Weight*	Wear Tape (optional)	Top Cap	Feeder	Spacer Tube
1205-36	1205-36-EXT	36' (11m)	40' (12.2m)	1/4" (6mm)	-10	#5 (4mm) .159" OD	0.11 lbs./ft (0.16 kg/m)	TL-154	1205-13	1205-02	1205-03 44"
1205-46	1205-46-EXT	46' (14m)	50' (15.2m)	1/4" (6mm)	-10	#5 (4mm) .159" OD	0.11 lbs./ft (0.16 kg/m)	TL-154	1205-13	1205-02	1205-03 44"
1706-46	1706-46-EXT	46' (14m)	50' (15.2m)	5/16" (8mm)	-17	#6 (5mm) .197" OD	0.17 lbs./ft (0.25 kg/m)	TL-154	1706-13	1706-02	2206-03 44"
1706-59	1706-59-EXT	59' (18m)	63' (19.2m)	5/16" (8mm)	-17	#6 (5mm) .197" OD	0.17 lbs./ft (0.25 kg/m)	TL-154	1706-13	1706-02	2206-03 44"
2206-59	2206-59-EXT	59' (18m)	63' (19.2m)	3/8" (10mm)	-22	#6 (5mm) .197" OD	0.24 lbs./ft (0.36 kg/m)	TL-205	2206-13	2206-02	2206-03 44"
2206-72	2206-72-EXT	72' (22m)	76' (23.2m)	3/8" (10mm)	-22	#6 (5mm) .197" OD	0.24 lbs./ft (0.36 kg/m)	TL-205	2206-13	2206-02	2206-03 44"
3007-80	3007-80-EXT	80' (24.3m)	86' (26.1m)	7/16" (11mm)	-30	#7 (6mm) .236" OD	0.30 lbs./ft (0.45 kg/m)	TL-205	3007-13	3007-02	3007-03 60"
4807-95	4807-95-EXT	95' (28.9m)	101' (30.7m)	9/16" (14mm)	-48	#7 (6mm) .236" OD	0.41 lbs./ft (0.62 kg/m)	TL-205	4807-13	4807-02	4807-03 72"
6008-110	6008-110-EXT	110' (33.5m)	116' (33.5m)	3/4" (18mm)	-60	#8 (7mm) .275" OD	0.46 lbs./ft (0.69 kg/m)	TL-306	6008-13	6008-02	6008-03 72"
7608-130	7608-130-EXT	130' (39.6m)	136' (40.8m)	3/4" (20mm)	-76	#8 (7mm) .275" OD	0.51 lbs./ft (0.77 kg/m)	TL-306	---	7608-02	7608-03 72"

All 1205, 1706, and 2206 systems may be shipped UPS or FedEx.  
All 3007, 4807, 6008 and 7608 must be shipped by truck.



# The Battslide® Mainsail System

Schaefer's Battslide System allows for full articulation between Mainsail hardware and the mast, thus reducing friction aloft and in the cockpit. Engineered to work to Schaefer's legendary reputation, all Battslide parts are made from the highest quality marine grade materials.

Do you suffer from a Mainsail that defies gravity?  
Do you decide to leave your Mainsail under cover for fear that raising it will create more aggravation?  
Then... Schaefer has a choice for you!

We offer several arrangements designed to work with your existing sail, mast and budget. Schaefer Battslide Receptacles, Headboard plate and Intermediate Slide Boss are added only to the luff of your existing mainsail. With systems and receptacles for boats from 20' - 200', Schaefer provides you the versatility to fit most Mainsails regardless of age, material and batten size.

Read on and find your solution or contact us for immediate assistance.

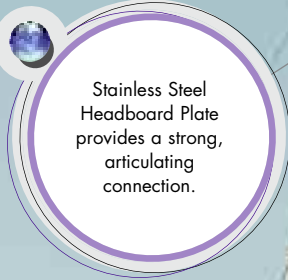

Stainless Steel Headboard Plate provides a strong, articulating connection.

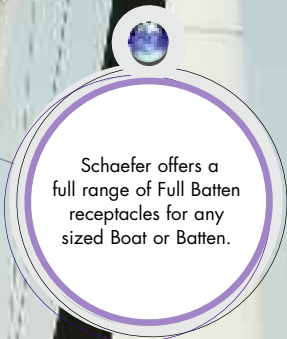

Schaefer offers a full range of Full Batten receptacles for any sized Boat or Batten.



Schaefer provides a solution for twisted slides with our unique Intermediate Slide Boss.

# The Battslide® Mainsail Track System

Battslide® Track for boats from 30'-45'

Serves as an easy replacement of existing or damaged sail track. It works equally well with Battslide and Allslip slides.

Battslide's Mainsail Track System for boats from 30-45 ft. accepts 7/8" flat slides. This is a simple way to replace worn or damaged sail track without re-engineering the sail. Key features of the new Battslide track are:

- Smooth, internal flat shape maintains low-friction surface and protects sliding surfaces from damage.
- Lightweight anodized 6061-T6 aluminum, pre-drilled for #10 FH fasteners on 3" centers easily fitting to curved and flat mast contours.
- Captive aluminum joints ensure track alignment.
- Removable "track gate" for loading sail allows a low slide stack.
- Smooth glass reinforced nylon end stops
- This system works best with standard Battslide slides, part #803, #889 Slide Boss and our headboard fitting #844. You may also use standard 7/8" flat slides.



Track does not include receptacles/slides shown

Battslide® Mainsail System consists of three major components:  
**Battslide® Headboard System**  
**Battslide® Full-length Batten Receptacles**  
**Battslide® Intermediate Slides**

If you have any questions about your choices, contact Schaefer for assistance.

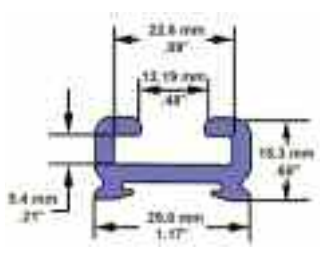

Part #8750 system kit includes the following:

- Six lengths of 7'7" long track
- One length track 25" as bottom length
- One 4" removal gate, seven track joints
- Two end stops







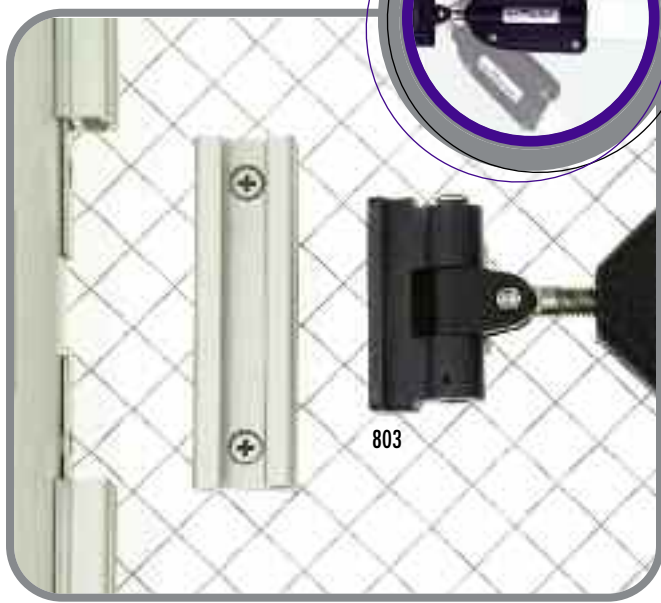
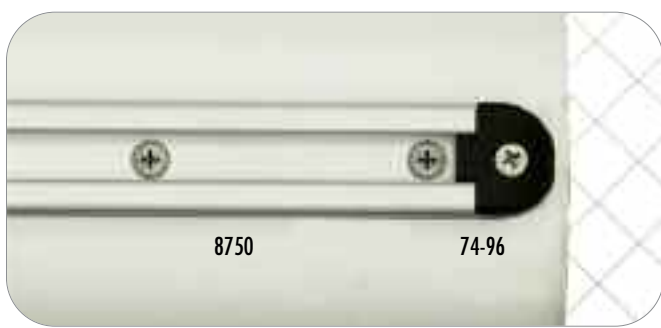

Total system track length: 47' 10"

**8750-10** extrusion extension kit  
**8750-15** 15 7" drilled track

#401 Receptacle, #803 Slide and Battslide Track shown with gate open. Note the captive joints that assure track alignment.

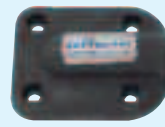

# Battslides for Monohulls up to 35'

<p><b>1</b> SIZE AND SHAPE OF BATTEN</p>	<p>FLAT: UP TO .63" x .28" (16MM x 7MM) ROUND: UP TO .28" (7MM)</p>	<p>FLAT: UP TO .625" (15MM) ROUND: UP TO .375" (10MM)</p>	<p>FLAT: UP TO 1.6" (40MM) ROUND: UP TO 1/2" (12MM)</p>
<p><b>2</b> CHOOSE FULL BATTEN RECEPTACLE</p>	 <p>440-10</p>	 <p>1500-10 OR 1500-BR (BOLT ROPE)</p>	 <p>450-10 OR 450-N</p>
<p><b>3</b> CHOOSE HEADBOARD FITTING</p>	 <p>844</p>	 <p>844</p>	 <p>844</p>
<p><b>4</b> CHOOSE INTERMEDIATE FITTING</p>	 <p>889</p>	 <p>889</p>	 <p>889</p>
<p><b>5</b> CHOOSE FROM SCHAEFER TOGGLE/LINKS OR STANDARD SAIL SLIDES</p>	<p>5/8" (15.9mm) FLAT INTERNAL TRACK CHALLENGE SITN5, CHALLENGE SITS5, BAINBRIDGE A007</p> <hr/> <p>3/4" (19MM) &amp; #6MM FLAT INTERNAL TRACK CHALLENGE SITN6, CHALLENGE SITS6 BAINBRIDGE A008</p> <hr/> <p>7/8" (22.2MM) FLAT INTERNAL TRACK CHALLENGE SITN7, CHALLENGE SITS7 BAINBRIDGE A009</p> <hr/> <p>METALMAST #8 FLAT INTERNAL TRACK CHALLENGE SMN8 BAINBRIDGE A008M</p> <hr/> <p>.40" (10MM) SHALLOW GROOVE (.32") ROUND INTERNAL TRACK SCHAEFER 833, CHALLENGE SAP6 BAINBRIDGE A017</p> <hr/> <p>.42" (10MM) DEEP GROOVE (.39") ROUND INTERNAL TRACK SCHAEFER 831, CHALLENGE SAP6 BAINBRIDGE A017</p>	<p>5/8" (15.9mm) FLAT INTERNAL TRACK SCHAEFER 865, CHALLENGE SITN5 CHALLENGE SITS5, BAINBRIDGE A007</p> <hr/> <p>3/4" (19MM) &amp; #6MM FLAT INTERNAL TRACK SCHAEFER 804, CHALLENGE SITN6 CHALLENGE SITS6, BAINBRIDGE A008</p> <hr/> <p>7/8" (22.2MM) FLAT INTERNAL TRACK SCHAEFER 803, CHALLENGE SITN7 CHALLENGE SITS7, BAINBRIDGE A009</p> <hr/> <p>METALMAST #8 FLAT INTERNAL TRACK SCHAEFER 802, CHALLENGE SMN8 BAINBRIDGE A008M</p> <hr/> <p>1.0" (25.4MM) FLAT INTERNAL TRACK SCHAEFER 801</p> <hr/> <p>.40" (10MM) SHALLOW GROOVE (.32") ROUND INTERNAL TRACK SCHAEFER 833 CHALLENGE SAP6 BAINBRIDGE A017</p> <hr/> <p>.42" (10MM) DEEP (.32") ROUND INTERNAL TRACK SCHAEFER 831, CHALLENGE SAP6 BAINBRIDGE A017</p>	<p>5/8" (15.9mm) FLAT INTERNAL TRACK SCHAEFER 865, CHALLENGE SITN5 CHALLENGE SITS5, BAINBRIDGE A007</p> <hr/> <p>3/4" (19MM) &amp; #6MM FLAT INTERNAL TRACK SCHAEFER 804, CHALLENGE SITN6 CHALLENGE SITS6, BAINBRIDGE A008</p> <hr/> <p>7/8" (22.2MM) FLAT INTERNAL TRACK SCHAEFER 803, CHALLENGE SITN7 CHALLENGE SITS7, BAINBRIDGE A009</p> <hr/> <p>METALMAST #8 FLAT INTERNAL TRACK SCHAEFER 802, CHALLENGE SMN8 BAINBRIDGE A008M</p> <hr/> <p>1.0" (25.4MM) FLAT INTERNAL TRACK SCHAEFER 801</p> <hr/> <p>.40" (10MM) SHALLOW GROOVE (.32") ROUND INTERNAL TRACK SCHAEFER 833, CHALLENGE SAP6 BAINBRIDGE A017</p> <hr/> <p>.42" (10MM) DEEP (.32") ROUND INTERNAL TRACK SCHAEFER 831, CHALLENGE SAP6 BAINBRIDGE A017</p>
	<p>MONOHULLS TO 28' (8.5M)</p>	<p>MONOHULLS TO 35' (10.6M)</p>	<p>MONOHULLS TO 35' (10.6M)</p>

## Schaefer Battslide – Boats to 35' (10.7m)

Schaefer's Battslide system offers solutions for Mainsails on a variety of Boats.

First, determine your batten size and quantity and select the appropriate Full Batten Receptacle. These receptacles work with Schaefer toggle/slides or with the addition of our shackle (466) with a variety of sail slides. The intermediate 889 and 844 Headboard Plate allows full articulation between sail slides and your sail for trouble free hoisting and lowering. Follow our chart on 100 or contact Schaefer with any questions.



### Battslide® Systems ONE Receptacle Selections

Part No.	Flat Max Batten Dim.	Round Max Batten Dim.	Adjustment Range	Nose Thread	Size L x W
440-10	0.63" x 0.28" (16mm x 7mm)	0.28" (7 mm)	0 0	10mm x 1.5	2-5/32" x 1-11/16" (65 x 110 mm)
450-10	1.6" x 0.20" (40.6mm x 5mm)	0.5" (13 mm)	0.625" (15.9mm at stud)	10mm x 1.5	2-5/8" x 4-7/16" (65 x 110 mm)
450-N	1.6" x 0.20" (40.6mm x 5mm)	0.5" (13 mm)	0 0	10mm x 1.5	2-5/8" x 4-7/16" (65 x 110 mm)
1500-10	19/32" x 5/16" (15mm x 8mm)	13 /32" (10 mm)	1-3/16" (30 mm)	10mm	4-1/16" x 2-5/16" (103 x 59mm)
1500-BR	19/32" x 5/16" (15mm x 8mm)	13 /32" (10 mm)	1-3/16" (30 mm)	Bolt Rope	4-1/16" x 2-5/16" (103 x 59mm)



1500-10



450-10



440-10



450-N

### Headboard Plates and Intermediates

#844 Stainless Headboard Plate For use with Battslide System Slides only. Accepts #466 or a 10 mm stud.

#889 Intermediate Slide Boss with 10mm stud and Stainless Shackle. Allows full articulation of slides. Accepts all Battslide system slides.



889



844

### Flat Internal Mast Slides

Item	Material	Size	Dimensions		
			A	B	C
801	NYLON	1.0" (25.4mm)	0.986	0.200	0.460
802	NYLON	MM#8	0.900	0.150	0.460
803	NYLON	7/8" (22.2mm)	0.850	0.175	0.420
804	NYLON	3/4" & MM#6 (19mm)	0.720	0.125	0.380
865	NYLON	5/8" (15.9mm)	0.610	0.125	0.280





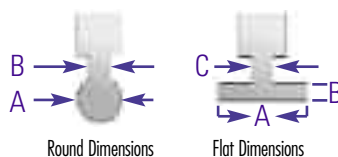

### Round Internal Mast Slides

Item	Material	Size	Dimensions
831	NYLON	1/2" (12.7mm)	.400" Deep
833	NYLON	1/2" (12.7mm)	.315" Deep

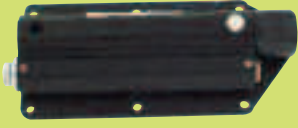

# Battslides for Monohulls up to 50'

<p><b>1</b> SIZE AND SHAPE OF BATTEN</p>	<p><b>FLAT: UP TO 3/4" (19MM) ROUND: UP TO 5/8" (19MM)</b></p>	<p><b>ROUND: UP TO 3/4" (19MM)</b></p>	
<p><b>2</b> CHOOSE FULL BATTEN RECEPTACLE</p>	 <p>1900-10, 1900-12 OR 1900-BR (BOLT ROPE)</p>	 <p>301-10 OR 301-12</p>	
<p><b>3</b> CHOOSE HEADBOARD FITTING</p>	 <p>844</p>	 <p>844</p>	
<p><b>4</b> CHOOSE INTERMEDIATE FITTING</p>	 <p>889</p>	 <p>889</p>	
<p><b>5</b> CHOOSE FROM SCHAEFER TOGGLE/LINKS OR STANDARD SAIL SLIDES</p>	<p>5/8" (15.9mm) FLAT INTERNAL TRACK SCHAEFER 865, CHALLENGE SITN5 CHALLENGE SITS5, BAINBRIDGE A007</p> <hr/> <p>3/4" (19MM) &amp; #6MM FLAT INTERNAL TRACK SCHAEFER 804, CHALLENGE SITN6 CHALLENGE SITS6, BAINBRIDGE A008</p> <hr/> <p>7/8" (22.2MM) FLAT INTERNAL TRACK SCHAEFER 803, CHALLENGE SITN7 CHALLENGE SITS7, BAINBRIDGE A009</p> <hr/> <p>METALMAST #8 FLAT INTERNAL TRACK SCHAEFER 802, CHALLENGE SMN8 BAINBRIDGE A008M</p> <hr/> <p>1.0" (25.4MM) FLAT INTERNAL TRACK SCHAEFER 801</p> <hr/> <p>.40" (10MM) SHALLOW GROOVE (.32") ROUND INTERNAL TRACK SCHAEFER 833, CHALLENGE SAP6 BAINBRIDGE A017</p> <hr/> <p>.42" (10MM) DEEP GROOVE (.39") ROUND INTERNAL TRACK SCHAEFER 831, CHALLENGE SAP6 BAINBRIDGE A017</p>	<p>5/8" (15.9mm) FLAT INTERNAL TRACK SCHAEFER 865, CHALLENGE SITN5 CHALLENGE SITS5, BAINBRIDGE A007</p> <hr/> <p>3/4" (19MM) &amp; #6MM FLAT INTERNAL TRACK SCHAEFER 804, CHALLENGE SITN6 CHALLENGE SITS6, BAINBRIDGE A008</p> <hr/> <p>7/8" (22.2MM) FLAT INTERNAL TRACK SCHAEFER 803, CHALLENGE SITN7 CHALLENGE SITS7, BAINBRIDGE A009</p> <hr/> <p>METALMAST #8 FLAT INTERNAL TRACK SCHAEFER 802, CHALLENGE SMN8 BAINBRIDGE A008M</p> <hr/> <p>1.0" (25.4MM) FLAT INTERNAL TRACK SCHAEFER 801</p> <hr/> <p>.40" (10MM) SHALLOW GROOVE (.32") ROUND INTERNAL TRACK SCHAEFER 833, CHALLENGE SAP6 BAINBRIDGE A017</p> <hr/> <p>.42" (10MM) DEEP ROUND INTERNAL TRACK SCHAEFER 831, CHALLENGE SAP6 BAINBRIDGE A017</p>	

## Schaefer Battslide – Boats to 50' (15.2m)

Schaefer's Battslide system offers solutions for Mainsails on a variety of Boats. First, determine your batten size and quantity and select the appropriate Full Batten Receptacle. These receptacles work with Schaefer toggle/slides or with competitors' luff track systems. The intermediate 889 and 844 Headboard Plate enables the use of standard sail slides or other track systems by allowing a 10mm fitting to articulate within each. Follow our chart on 102 or contact Schaefer with any questions.

### Battslide® Systems TWO Receptacle Selections

Part No.	Flat Max Batten Dim.	Round Max Batten Dim.	Adjustment Range	Nose Thread	Size L x W
301-10*	---	3/4" (19mm)	2" (49mm)	10mm	2-19/32" x 5-3/4" (66 x 146 mm)
301-12*	---	3/4" (19mm)	2" (49mm)	12mm	2-19/32" x 5-3/4" (66 x 146 mm)
1900-BR	7/8" x 3/8" (22mm x 10mm)	21/32" (16 mm)	1-1/2" (38mm at stud)	Bolt Rope	5-3/4" x 3" (172 x 76 mm)
1900-10	7/8" x 3/8" (22mm x 10mm)	21/32" (16 mm)	1-1/2" (38mm at stud)	10mm	5-3/4" x 3" (172 x 76 mm)
1900-12	7/8" x 3/8" (22mm x 10mm)	21/32" (16 mm)	1-1/2" (38mm at stud)	10mm	5-3/4" x 3" (172 x 76 mm)



301-10



1900-10

### Headboard Plates and Intermediates

#844 Stainless Headboard Plate For use with Battslide System Slides only. Accepts #466 or a 10 mm stud.

#889 Intermediate Slide Boss with 10mm stud and Stainless Shackles. Allows full articulation of slides. Accepts all Battslide system slides.



889



844

### Flat Internal Mast Slides

Item	Material	Size	Dimensions		
			A	B	C
801	NYLON	1.0" (25.4mm)	0.986	0.200	0.460
802	NYLON	MM#8	0.900	0.150	0.460
803	NYLON	7/8" (22.2mm)	0.850	0.175	0.420
804	NYLON	3/4" & MM#6 (19mm)	0.720	0.125	0.380
865	NYLON	5/8" (15.9mm)	0.610	0.125	0.280



### Round Internal Mast Slides

Item	Material	Size	Dimensions
831	NYLON	1/2" (12.7mm)	1/2" Deep Groove
833	NYLON	1/2" (12.7mm)	1/2" Shallow Groove

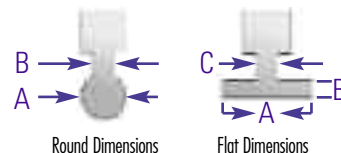



Machined 6061-T6 Aluminum Backing Plate for light and strong support.

Choose from six models that fit stud sizes from 10mm to 16mm in Stainless Steel Heli-Coil® inserts.

Machined 6061-T6 Aluminum Body keeps weight to a minimum and strength where you depend on it.

All models are leech loading and allow easy adjustment of Batten tension.

## Big Boat Battslide®

### Flat Batten Receptacles

Schaefer's Big Boat Flat Batten Receptacles are engineered to handle the extreme compression loads experienced on today's High Tech Mainsails. Our Machined Aluminum design keeps weight to a minimum and strength where you need it. Choose from six models that fit stud sizes from 10mm to 16mm in Stainless Steel Heli Coil inserts. All models are leech loading and allow easy adjustment of Batten tension for proper sail shape.

#### Battslide® #3200, #4500 and #6000 Receptacle Specifications Chart

Part No. Dimension	Flat Max Batten Range	Adjustment Thread	Nose L x W	Size	Weight
3200-10	32 x 12mm	2.5" 64 mm	10mm x 1.5	3" x 7.25 76 x 184 mm	1.1 lbs. 0.5 kg
3200-12	32 x 12mm	2.5" 64 mm	12mm x 1.75	3" x 7.25 76 x 184 mm	1.1 lbs. 0.5 kg
4500-12	45 x 15mm	3.75" 95 mm	12mm x 1.75	3.5" x 9.5 89 x 241mm	2.1 lbs. 1.0 kg
4500-14	45 x 15mm	3.75" 95 mm	14mm x 2.0	3.5" x 9.5 89 x 241mm	2.1 lbs. 1.0 kg
6000-14	60 x 18mm	4.5" 114 mm	14mm x 2.0	4.5" x 11.75 114 x 300mm	4.2 lbs. 1.9 kg
6000-16	60 x 18mm	4.5" 114 mm	16mm x 2.0	4.5" x 11.75 114 x 300mm	4.2 lbs. 1.9 kg



Round Batten Adaptors Shown Actual Size

021

022

051

052

053

054

082

083

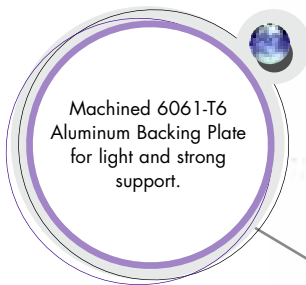

Machined 6061-T6 Aluminum Backing Plate for light and strong support.



All models are leech loading and allow easy adjustment of Batten tension.

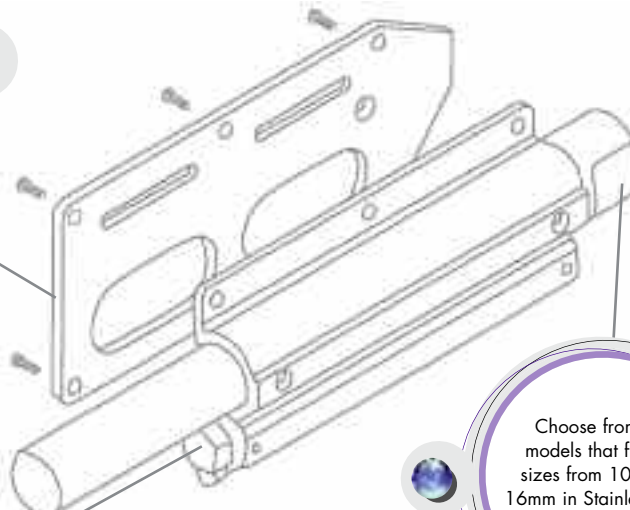

Choose from six models that fit stud sizes from 10mm to 16mm in Stainless Steel Heli-Coil® inserts.



301-10

382-14

351-12

### Receptacles for Round Battens

Made of 6061-T6 Aluminum, Schaefer's Big Boat Round Batten Receptacles include a lightweight, hardcoat finished backing plate. All models allow for easy attachment to other track systems. Track car studs fit into Stainless Steel Heli-Coil® inserts (available stud sizes are 10, 12, 14 and 16 mm).

Removable Nose-Piece allows for front-end loading of Full Battens. Each model allows for easy tensioning for proper sail shape. -Choose from our wide range of batten adaptors to ensure proper fit into the receptacle.

#### Round Batten Adaptors

##### \*Batten Adaptors for 301 Series

- 021** 7/16" AND 1/2" (11.1mm AND 12.7mm)
- 022** 5/16" AND 3/8" (7.9mm AND 9.5mm)

##### Batten Adaptors for #351 Series

- 051** 13/16" AND 7/8" (20.6 mm AND 22.2 mm)
- 052** 11/16" AND 3/4" (17.5 mm AND 19 mm)
- 053** 9/16" AND 5/8" (14.3 mm AND 15.8 mm)
- 054** 7/16" AND 1/2" (11.1 mm AND 12.7 mm)

##### Batten Adaptors for #382 Series

- 082** 7/8" AND 1.0" (20.6 mm AND 22.2 mm)
- 083** 11/16" AND 3/4" (17.5 mm AND 19 mm)

Part No. Dimension	Max. Batten Dimension	Min. Batten Range	Adjustment Thread	Nose L x W	Size
301-10	3/4" (19.0mm)	5/16" (7.9mm)	2" (49mm)	10mm x 1.5	2.60" x 5.75" (66 x 146mm)
301-12	3/4" (19.0mm)	5/16" (7.9mm)	2" (49mm)	12mm x 1.5	2.60" x 5.75" (66 x 146mm)
351-12	1" (25mm)	7/16" (11mm)	4.5" (144mm)	12mm x 1.5	3.05" x 8.5" (77 x 216mm)
351-14	1" (25mm)	7/16" (11mm)	4.5" (144mm)	14mm x 1.5	3.05" x 8.5" (77 x 216mm)
382-12	1.25" (31.8mm)	11/16" (17.5mm)	6.875" (175mm)	12mm x 1.5	3.72" x 11.75" (94 x 296mm)
382-14	1.25" (31.8mm)	11/16" (17.5mm)	6.875" (175mm)	14mm x 1.5	3.72" x 11.75" (94 x 296mm)



# Product Use and Index

## Using This Catalog

Boat size recommendations are based on average displacement monohull cruising and racing boats. Multi-hulls are not covered by these recommendations. Boats with high sailplan aspect ratios, heavy displacements, or very high stability should use a larger size fitting. Please contact Schaefer for specific recommendations.

Dimensions listed in chart format are taken from the maximum Length, Width, Thickness or Height of each individual product.

### Common Specifications

Use the common specifications guide as a quick reference for the general characteristics of a product grouping .

- Sheave diameter:**
- Sheave Width:**
- Maximum Line Diameter:**
- Pin Diameter:**
- SWL Aluminum/Stainless:**
- SWL Ball Bearing:**

- L** - Length
- W** - Width
- T** - Overall Thickness

LEGEND

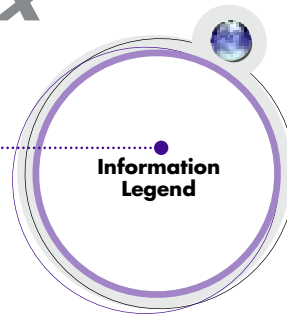

Look for our Information Legend located throughout our catalog for:

- Ideas**
- Product Details**
- Go To Pages**
- Product information**



Grid Product Reference

Products shown on background grid that measures 7/8" should be used only as a general size reference.



Look for our Warning Legend located throughout the catalog providing special instructions pertaining to safety or use considerations.

# SCHAEFER

## LEGENDARY STRENGTH

## Warning/Caution

Schaefer Marine Inc. products are designed and intended for use on sailboats for specific stated applications. Other non-sailboat applications for uses in other industries is not recommended without prior approval from Schaefer Marine.

Stainless Steel, aluminum, and plastics can degrade over time without much external evidence due to the effects of environmental exposure. We recommend that you inspect your hardware regularly for deformation, wear, cracks or corrosion. We will be happy to perform a free inspection on any Schaefer part returned to Schaefer Marine Inc. Please provide your daytime tel. number and complete address. Shipping charges will apply.

Contrary to common belief, Stainless Steel is *NOT* totally rustproof. All Stainless Steel will rust to a certain degree due to a natural chemical reaction to air and salt water particularly where there is abrasion, friction or welds. The appearance though, is mainly cosmetic and can be solved with metal polish and frequent fresh water rinsing.

Vessel construction methods and quality are highly variable. Proper reinforcement in the boat or mast and correct fastener size is essential to insure proper attachment of all fittings. Consultation from the boat manufacturer or a naval architect is recommended for any questionable applications.

## Safe Working Loads

The Safe Working Load (SWL) figure shown for our fittings represent the load to which the item may be loaded without deformation or damage to the fitting or its components. This figure represents the total load that should not be exceeded by either static or dynamic forces. (see Vessel construction above)

Do not select fittings based on loading of the line/wire only, as the actual load experienced by the fitting may be several times this figure. Total loading is dependent on line load, angle of load turning through a block and the amount of purchase involved in the system.

Do not select blocks based on the maximum line diameter capacity listed in the table, as modern synthetic line breaking strengths often exceed the safe working loads for the blocks. It is a common practice on most sailboats to use larger lines than the loads require because they are easier to handle and have a longer service life. If you are in doubt about the correct Schaefer fitting for your application, please contact us and we will assist you.

## Maintenance and Inspection

Prudent seamanship dictates that all of your marine hardware and blocks receive regular inspections for deformation, wear, cracks or corrosion. Even if your boat has had little use, environmental exposure, corrosion or the endless rocking action of the boat at the mooring may cause damage that could affect the strength of the fitting. If, after inspection, you are in doubt about the integrity or safety of any of your Schaefer fittings, send them to our factory and we will inspect them free of charge.



**SCHAEFER**  
**LEGENDARY STRENGTH**



## A Special Thanks

Schaefer Marine would like to extend a warm Thank You to all of the Photographers who have contributed to this publication. Daniel Forrester, Drew Fernandez, Ira Kerns, Tim Sylvia, Billy Black. And to the boats and their owners represented inside Catalina Yachts, J-Boats, Shannon Boats, Valiant Yachts.

All images reproduced within are under the prior copyrights of their owners. Nothing may be reproduced in any form without the permission of the owners. All Trademarks and Registered Trademarks are the property of their owners.

All printed information in this publication is accurate to the best of Schaefer Marines' knowledge. Specifications are subject to change without notice. Contact Schaefer Marine for the latest information on any product.

© 2011  
Schaefer Marine Inc.  
158 Duchaine Blvd.  
New Bedford, MA 02745-1293  
USA

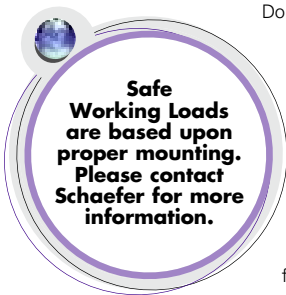





Schaefer Marine products are available through a world-wide organized network of dealers and distributors.

For assistance locating a dealer or parts for older equipment please contact Schaefer Customer Service at 508-995-9511,

Sales@SchaeferMarine.com or visit us online. Some hard to find replacement parts and our full hardware product

line are available to purchase through our Dock Cart system at [SchaeferMarine.com/hardware.asp](http://SchaeferMarine.com/hardware.asp)



## Returns & Repairs:

Goods returned will not be accepted or credited without prior authorization from Schaefer Marine. Made-to-order materials are not returnable. All returned goods are subject to a 20% restocking charge and refinishing or repacking charge as necessary. Goods must be in our possession within 30 days of our authorization, and shipped prepaid.

Address all requests for repairs and service to our Massachusetts facility, 158 Duchaine Blvd., New Bedford, MA 02745-1293 labeled "ATTENTION REPAIRS". Please make certain to include your return address and daytime telephone number so that we will be able to inform you of any charges relating to the repair as well as the return of your parts in a timely manner.



## Warranty:

Schaefer Marine, Inc. warrants its standard Hardware, Jib Furling, Boom Furling and Battslide catalog products to be free from factory defects in material and workmanship for a period of five (5) years from the date of purchase, unless otherwise stated in any Schaefer Marine written material. Schaefer Marine, Inc. warrants its standard TuffLuff catalog products to be free from factory defects in material and workmanship for a period of three (3) years from the date of purchase, unless otherwise stated in any Schaefer Marine written material.

At any time within the above list time frame of the demonstrated date of purchase, Schaefer Marine, Inc. will remedy any factory defect in material or workmanship (at no charge to the original purchaser) if the product is returned to Schaefer Marine, Inc. The buyer shall be responsible for shipping and insurance charges, if any, on the products returned for repair under the terms of this warranty. Schaefer Marine, Inc. will pay shipping for products returned to the buyer (when there is a warranty obligation). Return of defective products must be accompanied by a letter giving contact information: name, address, tel., proof of purchase, type of boat and description of malfunction of the gear.

This warranty extends only to defects in material or workmanship of products in normal marine use only. It does not extend to damage caused by accident or abuse, or to any consequential incidental losses or damages arising from the products or their use. This warranty does not extend to non marine applications. There are no other warranties, including that of merchant-ability, expressed or implied, other than those set forth herein which extend beyond the period of this warranty.

This warranty is in lieu of all other implied, express and statutory guarantees, and in no event or limitation of incidental or consequential damages, so the above limitations or exclusions may not apply to you. This warranty gives you specific legal rights, and you may also have other rights which may vary from state to state. Answers to any technical questions or questions regarding warranty or service may be obtained by contacting Schaefer Marine, Inc.